



# LUCKNOW METRO RAIL CORPORATION LIMITED

Administrative building, Vipin Khand, Gomti Nagar, Lucknow - 226010

E-mail id- [cecontractlmrc@gmail.com](mailto:cecontractlmrc@gmail.com)

No. LMRC/CE-Contract/KNPCC-03/2019-20

Date: 04.10.2019

To,  
All Bidders,

**Subject:** - Reply to Pre-bid queries & Addendum-01 for tender KNPCC-03.

**Ref:** - **Tender KNPCC-03:** Civil, PEB and E&M works for construction of depot cum workshop, including structural, architectural, plumbing, drainage, external development, road works, electrical, mechanical, VAC, firefighting, fire detection etc. at Polytechnic College Depot for IIT Kanpur to Naubasta Corridor-I of Kanpur Metro. Dear Sir,

Please find enclosed herewith the Reply to Pre-bid queries and Addendum-01 to the tender KNPCC-03. Further, the tender submission/Opening dates are revised as follows:

- Last date of issuing addendum : **04.10.2019**
- Date & time of Submission of Tender : **15.10.2019 up-to 15:00 Hrs**
- Date & time of opening of Tender (Technical Bid) : **15.10.2019 @ 15:30 Hrs.**

**Enclosure: As Above**



(Deepak Gupta)  
Chief Engineer/Contract

**Reply to Pre-Bid Queries KNPCC-03**

**Tender KNPCC-03:** Civil, PEB and E&M works for construction of depot cum workshop, including structural, architectural, plumbing, drainage, external development, road works, electrical, mechanical, VAC, fire fighting, fire detection etc. at Polytechnic College Depot for IIT Kanpur to Naubasta Corridor-1 of Kanpur Metro.

S. No.	Reference Clauses	Employer Requirement	Details / Clarifications Required	LMRC's Reply	
1	Clause 1.1.3.2 of NIT, Volume 1	Minimum Eligibility Criteria	"Similar work" for this contract shall be atleast one work of construction of Metro train depot / Metro stations works/ Metro building / Ramp comprising Civil, Architectural E&M works. For (ii) & (iii), the other work(s) can be RCC Framed building/Industrial Structure comprising Civil, Architectural & E& M works.	May please consider RCC Framed building/Industrial Structure comprising Civil, Architectural & E&M Works, against Similar Works.	As per Tender Condition.
2	Clause 1.1.3.1(i), Vol-01	QUALIFICATION CRITERIA	Joint Ventures and consortiums are not allowed to participate in the tender.	Joint venture may please be considered for bidding.	As per Tender Condition.
3	Annexure-3 [ As per clause C12.1], Instructions to Tenderers	RESOURCES PROPOSED FOR THE PROJECT - PERSONNEL:	-	When all detailed drawings for execution of work are being provided by LMRC, engaging Architect and Structural/Design Engineer full time, for the project shall unnecessary increase overheads of contractor. If services of Architect and Structural/Design Engineers are at all required, can be out sourced. May please clarify.	As per Tender Condition.
4	Instructions to Tenderers: Annexure-5 [As per clause C 13],	RESOURCES PROPOSED FOR THE PROJECT- PLANTS & EQUIPMENTS:	-	Total quantity of Ready Mix Concrete, required for the Project is 22000 Cum. (Approx.), as per BOQ. Is it really required to install Fully Automatic and Computerized Batching Plant having 30 Cum. / h minimum with an RO of suitable capacity for proper quality of water? Instead two Mobile batching plants can be installed at site, and for major quantity, it can be brought from RMC plant located outside the premises. May please Clarify.	As per Tender Condition.
5	-	-	-	Who shall be responsible for payment of Labour Cess, Contractor or LMRC, please clarify.	Please refer Clause C 2.6 (e) of Instructions to Tenderers (ITT), Volume-1.
6	-	-	-	Cost of Barricades of the complete perimeter of all works areas, as desired by LMRC, is going to be very high, As we understand that boundary wall is already build what exactly is the purpose of such Barricades. May please consider and clarify.	Barricading along the complete perimeter of depot is not required. However contractor has to ensure adequate safety & protection of man & material during execution in work areas.
7	S.No. 3, 15 of Section 1.16 List of approved makes of material under Technical Specifications for E&M works, Volume-4	-	-	Vendor list of E&M works under Volume-4, Technical Specifications for E&M works section 1.16 List of approved makes of material S.No. 3, 15 and 48 refers to specified makes only Instead of given makes additionally we request to add Ebullient make cables also. We confirm that our proposed make will meet all the project specifications. May please consider and clarify	Kindly refer Sub Head ' Vendor Approval & Selection Procedure' of Clause 1.16 of Technical Specifications -E&M, Volume-4.
8	-	-	-	Preamble to be followed in case of any dispute among BOQ / Project Specifications /Contract drawings/ Standard code of Practice / NBC / Related International code. May Please Clarify regard order to follow in case of such disputes?	Kindly refer Clause 1.5 of General Conditions of Contract (GCC), Volume-2.
9	-	-	-	It is understood that the drawings provided in the tender are of preliminary. As and when detailed design will be made available any items which is not in BOQ will be consider as "new Item" For such items until Engineer Instruction in writing will not received it will not consider as part of contract. May please consider and clarify.	<b>Please refer revised drawings in Annexure-13 of Addendum-01.</b> For "new items"/Items not covered in BOQ, the rates shall be decided as per Clause 12.5(g) of GCC, Volume-2.

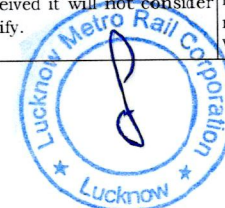



10	Vol.-1, NIT, Clause 1.1.3.2,	Minimum Eligibility Criteria	"Similar work" for this contract shall be atleast one work of construction of Metro train depot / Metro stations works/ Metro building / Ramp comprising Civil, Architectural E&M works. For (ii) & (iii), the other work(s) can be RCC Framed building/Industrial Structure comprising Civil, Architectural & E& M works.	***"Similar work" for this contract shall be work of construction of Metro train depot/ Metro stations/ Metro building / Composite Steel Non-residential works/ Ramp comprising Civil, Architectural & E&M works. - Please Clarify	As per Tender Condition
11	Vol.-II, GCC Cl.1.1.2.1 Page 53	Mobilization Advance & Recovery	Mobilisation Advance shall be generally 5% of original contract value payable in two equal instalments or as mentioned in the Special Conditions of Contract. The first instalment shall be paid after mobilisation has started and next instalment shall be paid after satisfactory utilization of earlier instalment.	We request you to 10% Interest free mobilization advance shall be released along with work order against bank guarantee. -Please Clarify.	As per Tender Condition
12	Vol.-1 Appendix -I, Pg. 42	Performance Guarantee	10% of the Contract Price in types and proportions of currencies in which the contract price is payable. In the event of variations during the execution of the contract which result in payments to the Contractor over and above the contract price, the Performance Security shall be adjusted in accordance with clause 4.2 of GCC.	We will provide 5% of the contract value Performance Guarantee in lieu of 10% . Please clarify.	As per Tender Condition
13	Vol.-2 Cl.11.1.1 Pg.98	Taxes	(a) The contract price, subject to any adjustment thereto in accordance with the contract shall be all inclusive (including all taxes, duties, royalties etc.) including Goods and Service Taxes (GST).	We request you to any variation in the rate due to change in Taxes/Statutory Government liabilities or any imposition of New Taxes change of existing taxes shall be borne by Owner. - Please clarify	Kindly refer Clause 11.1.3(v) of Special Conditions of Contract (SCC), Volume-2.
14	-	-	GST	Applicable GST Rate @18% or @12%- Please clarify.	At present the Applicable GST rate for metro works is 12%. Kindly also refer Clause 11.1.3 (v) of Special Conditions of Contract (SCC), Volume-2.
15	-	-	Labour Cess	Applicable labour cess will be @1% is inclusive or exclusive - Please clarify	Please refer Clause C 2.6 (e) of Instructions to Tenderers (ITT), Volume-1, wherein Labour Cess is inclusive in contract price.
16	-	-	Statutory Approvals & compliance	We have considered that all necessary statutory approvals, permissions, sanctions, NOC from local body, MOEF, state govt., central govt. etc shall be arranged and paid by owner. All the necessary deposits, fees, expenditures for all type of permission/ sanctions etc. including extra water and sewage charge, shall be paid by owner. Please Clarify.	Please refer Clause 2.3 of General Conditions of Contract (GCC), Volume-2.
17	Vol.-3 Appendix 2A, Pg.71	Space for site office, material, store, Labour Accomodation etc.	No Separate land will be provided by LMRC for Casting Yard, Batching Plants, Site Office, Site Laboratory, stores etc. Contractor have to make these provision in depot area only.	Considered with space for Site office, labour hutment storage of material, cement godawn, store, Batching plant & fabrication yard etc. provided by client free of cost at site. Please Clarify. -	Kindly refer Clause 2.2.12 of Employer's Requirement - Functional, Volume-3 & Clause 1 of Attachment-A 'Contractors Labour Camp', Employer's Requirement, Volume-3.
18	Vol.-4 Technical Specification Pg.138-142 & E&M Pg.19-23	Approved Makes	List of approved make given in the tender document.	Considered with rates are quoted based on any make can be use in place of first make from the list of approved or equivalent makes as given in the tender and no deduction will be done on account of using approved make other than first make. Please clarify.	Kindly refer Sub-Clause (i), (ii) & (iii) & Sub Head 'Vendor Approval' of Clause 1.16 of Technical Specifications -E&M, Volume-4.
19	-	-	-	Clear access to site in workable condition shall be provided by client. Please clarify.	As per Clause 2.2.1(ii) of Employer's Requirement - Functional, Volume-3, site clearance & demolition of obstructions if any, before commencement of work is in the scope of work.
20	Vol.-1 Appendix 1 Pg.42	Defect Liability period	52 weeks after the date of issue of Taking-Over Certificate for the Whole of the Works.	We have considered defect liability period will be 12 months from the date of virtual completion of the project.	As per Tender Condition.
21	PF & ESI	-	-	Our rates are inclusive of P.F.& ESI based on current applicable rules. Any variation in future in applicable rules shall be reimbursed by client.	Contract Price is all inclusive and any variation due to change in applicable rules (PF & ESI) shall not be borne by the employer (LMRC).

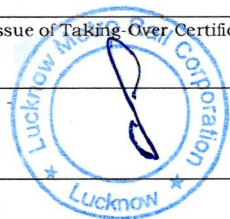



22	Vol.-2 Cl.1.1.1.3 Pg.98	Escalation	No adjustment in contract price on account of inflation shall be done for E & M works (Schedule-E of Volume -6).	Considered with escalation will be applicable for all materials, labours & fuels as per the CPWD/Government norms. - Please clarify.	As per Tender Condition.
23	NIT Vol-1	Dates	Extension of time for submission of tender-	We request you to various Specialized agencies of works. We request you to please extend the date of submission of tender atleast three weeks after the date of reply of pre-bid queries. - Please clarify.	As per Tender Condition.
24	BOQ	-	Avalaiaible In Hard copy only.	Please provide the Soft copy of Bill of Quantity & tender document.- Please clarify.	Soft copies of Tender Document & BOQ are being provided with Addendum-01. Kindly refer to the same.
25	-	-	Soil Report	Soil investigation report is not avaiable along with tender document. Please provide the Soil investigation report- Please clarify.	Kindly refer Clause 5.3.3 of Chapter-5 of Detailed Project Report (DPR) of Kanpur Metro available on LMRC's website, wherein Geotechnical Investigation data of Depot Area has been mentioned.
26	Vol-5	-	Tender Drawings	Sectional & Elevation drawing for work shop OCC & admin building is not available along with tender document.However plan drawing is available alongwith tender document. Please provide drawing for workshop building ,OCC & Admin building - Please clarify.	<b>Please refer revised drawings provided in Annexure-13 of Addendum-1</b>
27	Item 2.10 of Schedule-A DSR-2018 Items, BOQ, Volume-6, Pg. 8	-	B.O.Q. Sr. no 2.10 Felling tree.	Considered with permission for tree cutting from the govt. Authority shall be taken by client at his own cost.- Please clarify.	Kindly refer Clause 3.8.4 of Employer's Requirement - Construction, Volume-3.
28	Basic Rate of Cement, Reinforcement Steel & Structural Steel	-	-	Basic rate not mentioned in the Tender document. Please provide the basic rate for cement, Reinforcement steel & Structural Steel.	Kindly refer BOQ wherein rates for cement & reinforcement are based on DSR-2018 items.
29	SUB HEAD -8 Flooring Work	-	-	No basic rate mentioned in the B.O.Q for flooring stone & Tiling. We request you to provide the basic rate for flooring stone & Tile - Please clarify.	Kindly refer BOQ wherein rates for flooring work are based on DSR-2018 items.
30	Vol.-4 Technical Specification Pg.138-142	List of approved make	List of approved make given in the tender document.	We request you to add the name of following make in the list of approved make. Flush doors- Merino/Century/Archid Ready Mixed Concrete- Locally avaiable make. Rolling Shutter - Dhiman Industries ltd/Rama Rolling Shutter/ Bhawani Rolling Shutter- Please clarify.	Kindly refer para of Clause 16 'Makes of Material/Products' of Technical Specifications - Civil & Plumbling, Volume-4.
31	-	-	-	We request you to if any further clarification required from client during the bid preparation then allow to us for further clarification. Please clarify.	As per tender conditions.
32	-	-	-	We request you to please circulate reply of pre- bid points to all bidders Please clarify.	Reply to prebid queries is given to all the bidders and also available on LMRC's website.
33	Vol.-1, NIT, Clause 1.1.3.2,	Minimum Eligibility Criteria	"Similar work" for this contract shall be atleast one work of construction of Metro train depot / Metro stations works/ Metro building / Ramp comprising Civil, Architectural E&M works. For (ii) & (iii), the other work(s) can be RCC Framed building/Industrial Structure comprising Civil, Architectural & E& M works.	Is experience of commercial work /Industrial work/Airport infrastructure work will be countable/acceptable or not.	As per Tender Condition.
34	Vol.-1, NIT, Clause 1.1.3.3,	Bid capacity criteria-	A = Maximum of the value of construction works executed in any one year during the last five financial years (updated to 31/07/2019 price level assuming 5% inflation for Indian Rupees every year and 2% for foreign currency portions per year).	Can the work executed in last ten financial years will be countable/acceptable or not.	As per Tender Condition.
35	Vol.-1, NIT, Clause 1.1.2	Key Details	approximate cost of work 105.00 Crs.	approximate cost of work is 105.00 Crores - Is cost inclusive GST or exclusive.	Amount is inclusive of GST.





36	Vol.-1, NIT, Clause 1.1.2	Key Details	<i>Tender Security</i>	tender security amount is 1.05 crores- will be in form of DD/BG/FDR.	Please refer Clause C18 of ITT, Vol-01, acceptable forms of Tender Security are Bank Guarantee/Irrevocable Letter of Credit/Demand Draft.
37	-	-	Approvals	Government approval/NOC like firefighting/air pollution/Airport authority/Environmental & Mining/Local authorities' approvals will be in scope of LMRC or contractors.	Kindly refer Clause 1.3 & 22nd bullet of Clause 2.2.4.3.1 of Employer's Requirement - Functional, Volume-3.
	Vol.-1, NIT, Clause 1.1.3.2,	Minimum Eligibility Criteria	"Similar work" for this contract shall be atleast one work of construction of Metro train depot / Metro stations works/ Metro building / Ramp comprising Civil, Architectural E&M works. For (ii) & (iii), the other work(s) can be RCC Framed building/Industrial Structure comprising Civil, Architectural & E& M works.	Request to add the 'Institutional/Hospital' project in similar work definition of NIT Page No-2	As per Tender Condition.
39	-	-	-	Request to extend the date of Purchase of tender by 2 days.	As per Tender Condition.
40	Clause 1.1.3.1(i), Vol-01	QUALIFICATION CRITERIA	Joint Ventures and consortiums are not allowed to participate in the tender.	Request to allow Joint venture to participate in Bidding process.	As per Tender Condition.
41	Drawings				
			<b>Building Name</b>	<b>Drawing Required</b>	
			1) Starting shed	1) All Plans above Plinth Beam level 2) Cross Section - (Longitudinal and Cross) 3) Elevation	<b>Please refer drawings provide in Annexure-13 of Addendum-1.</b>  Above drawings along with those provided in Volume-5 of Tender Documents, are tender stage drawings for reference pupose. However, actual constructions will be based on approved drawings.
			2) Work Shop, DCC, Admin Cym OCC Building	1) Cross Section (Longitudinal and Cross) 2) Elevation	
			3) Substation	1) Column Layout Plan 2) Framing Plan at plinth level 3) Framing Plan of roof Level 4) Section 5) Elevation	
			4) Diesel Generation	1) Plan 2) Section 3) Elevation	
			5) Auto coach washing plant	1) Column Layout 2) Framing Plan at plinth level 3) Framing Plan at roof Level 4) Section 5) Elevation	
			6) Pit wheel latre	1) Column Layout Plan 2) Framing Plan at plinth level 3) Framing Plan at roof Level	
			7) Pump Room and U.G. Tank	1) Plan 2) Section	
			8) Over head Tank	1) Plan 2) Section	

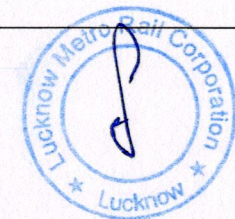



**Summary Sheet of ADDENDUM No.-1: Contract KNPCC-03**

**Tender KNPCC-03: Civil, PEB and E&M works for construction of depot cum workshop, including structural, architectural, plumbing, drainage, external development, road works, electrical, mechanical, VAC, fire fighting, fire detection etc. at Polytechnic College Depot for IIT Kanpur to Naubasta Corridor-1 of Kanpur Metro.**

S. NO.	Existing Clause / Pg. No.	Clause in Existing Tender Document	Revised Clause	Revised Clause placed as Annexure/ Pg. No.
1	Clause C2.3 (g) (A)(ii)(b) of ITT, Vol.-1, Pg. 12	(b) Value of the commitments and on-going works, on an yearly basis, pertaining to Civil Engineering construction, to be completed during the next 24 months from the first date of the month of the tender submission.	(b) Value of the commitments and on-going works, on an yearly basis, pertaining to Civil Engineering construction, to be completed during the next <b>24 18</b> months from the first date of the month of the tender submission.	Annexure-1, Pg. 12 R1
2	Clause C2.6 (e) of ITT, Vol.-1, Page 13	e) No documents with regard to Custom and Excise duty will be required to be submitted. In view of above, the tenderers are advised to quote the price inclusive of Goods and Services Tax (GST), duties, levies, cess and all other incidental charges required to fulfil the tender conditions including statutory deduction viz., TDS towards Income Tax / GST/ Labour Cess etc. after considering clause C2.4, C2.5 & C2.6 above.	e) No documents with regard to Custom <del>and Excise</del> duty will be required to be submitted. In view of above, the tenderers are advised to quote the price inclusive of Goods and Services Tax (GST), duties, levies, cess and all other incidental charges required to fulfil the tender conditions including statutory deduction viz., TDS towards Income Tax / GST/ Labour Cess etc. after considering clause C2.4, C2.5 & C2.6 above. <b>Any GST, duties, levies cess, which are required/may be required to be paid by the Employer in the fulfilment of the tender conditions including on reverse charge basis should also be included by the tenderer in the Contract Price.</b>	Annexure-2, Pg. 13 R1
3	Annexure-6 & Annexure-7 of ITT, Vol.-1, Page 35 & 37	<i>Heading</i> 'CONTRACT LKCC 03'	<i>Heading corrected as</i> 'CONTRACT LKCC-03 <b>KNPCC-03</b> '	Annexure-3, Pg. 35 R1 & Annexure-4, Pg. 37 R1
3	Clause 25 of SCC, page no.-98	(a) The contract price, subject to any adjustment thereto in accordance with the contract shall be all inclusive (including all taxes, duties, royalties etc.) including Goods and Service Taxes (GST). (b) The contract price shall be quoted in Indian Rupees Only. (c) Taxes and duties paid to the sub-vendors shall not be paid separately and therefore are to be included in the price. (d) Tenderers shall submit an undertaking that neither they nor their sub-contractors / sub-vendors shall avail the deemed export benefit as the same shall be availed directly by LMRC and retained.	(a) The contract price, subject to any adjustment thereto in accordance with the contract shall be all inclusive (including all taxes, duties, royalties etc.) including Goods and Service Taxes (GST). <b>Any GST, duties, levies cess, which are required/may be required to be paid by the Employer in the fulfilment of the tender conditions including on reverse charge basis should also be included by the tenderer in the Contract Price, Foreign tenderers participating through consortium or otherwise must include all GST and other taxes, payable by the Employer in respect of all contractual payments made to the foreign tenderer.</b> (b) The contract price shall be quoted in Indian Rupees Only. (c) <del>Taxes and duties paid to the sub-vendors shall not be paid separately and therefore are to be included in the price.</del>	Annexure-4, pg. 25R1
4	Annexures to ITT, Vol-1.	-	<b>Form of Bank Guarantee for Mobilization of Advance and Plant &amp; machinery Advance' is provided as Annexure-7A to ITT.</b>	Annexure-5, Page 38A to 38B
5	S. No. 25, Clause 11.1.1 of SCC, Vol.-2, Page 98	(a) The contract price, subject to any adjustment thereto in accordance with the contract shall be all inclusive (including all taxes, duties, royalties etc.) including Goods and Service Taxes (GST). (b) The contract price shall be quoted in Indian Rupees Only. (c) Taxes and duties paid to the sub-vendors shall not be paid separately and therefore are to be included in the price. (d) Tenderers shall submit an undertaking that neither they nor their sub-contractors / sub-vendors shall avail the deemed export benefit as the same shall be availed directly by LMRC and retained.	(a) The contract price, subject to any adjustment thereto in accordance with the contract shall be all inclusive (including all taxes, duties, royalties etc.) including Goods and Service Taxes (GST). <b>Any GST, duties, levies cess, which are required/may be required to be paid by the Employer in the fulfilment of the tender conditions including on reverse charge basis should also be included by the tenderer in the Contract Price.</b> (b) The contract price shall be quoted in Indian Rupees Only. (c) <del>Taxes and duties paid to the sub-vendors shall not be paid separately and therefore are to be included in the price.</del> (d) Tenderers shall submit an undertaking that neither they nor their sub-contractors / sub-vendors shall avail the deemed export benefit as the same shall be availed directly by LMRC and retained.	Annexure-6, Page 98R1

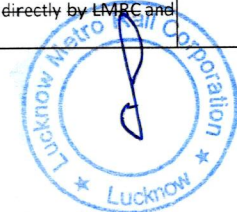



S. NO.	Existing Clause / Pg. No.	Clause in Existing Tender Document	Revised Clause	Revised Clause placed as Annexure/ Pg. No.
6	S.No. 30, Clause 11.6 of SCC, Vol.-2, Page 103	<b>Interim Payment / Running Account Payment</b> After preliminary scrutiny and certification by Engineer, payment of 80% of the certified interim amount/Running account Payment shall be made by the Employer within 7 days. The amount certified shall account for all deductions, including statutory deductions, recoveries for advances and any amounts due from the Contractor. The balance 20% shall be paid within 21 days, from the date of preliminary certification of the bill by the Engineer.	<b>Interim Payment / Running Account Payment</b> After preliminary scrutiny and certification by Engineer, payment of 80% of the certified interim amount/Running account Payment shall be made by the Employer within 7 days. The amount certified shall account for all deductions, including statutory deductions, recoveries for advances and any amounts due from the Contractor. The balance 20% shall be paid within 21 days, from the date of preliminary certification of the bill by the Engineer. <b><u>Proper GST invoice should be submitted as per taxation laws to facilitate payment.</u></b>	Annexure-7, Page 103R1
7	2nd Para of Clause 4, Schedule -1 Contract Agreement, SCC, Vol-2, Page 111	The above amounts include all taxes, duties, royalties, GST and other levies etc.	The above amounts include all taxes, duties, royalties, GST and other levies etc. <b>and including all taxes, duties, cess, royalties, GST and other levies payable by the Employer under reserve charge basis or otherwise, for the fulfillment of the Contract obligations.</b>	Annexure-8, Page 111R1
8	Clause 3.10, Site Establishment, Employer's Requirement - Construction, Vol.-3, Page 47	<b>Sub-head 'CONTRACTOR'S SITE ACCOMMODATION'</b> The Contractor shall provide and maintain its own site accommodation at locations consented to by the Engineer. Offices, sheds, stores, mess rooms, garages, workshops, latrines and other accommodation on the Site shall be maintained in a clean, stable and secure condition. Living accommodation shall not be provided on the Site. The Contractor shall comply with the requirements of Attachment 'A' to the Employer's Requirements. The contractor shall also provide a fully furnished office of nearly 80 sqm area at its own cost and maintain at its cost two (02) road vehicles (Mahindra Scorpio or similar – alongwith drivers available for 24hrs a day) for use/utilization by LMRC.	<b>Sub-head 'CONTRACTOR'S SITE ACCOMMODATION'</b> The Contractor shall provide and maintain its own site accommodation at locations consented to by the Engineer. Offices, sheds, stores, mess rooms, garages, workshops, latrines and other accommodation on the Site shall be maintained in a clean, stable and secure condition. Living accommodation shall not be provided on the Site. The Contractor shall comply with the requirements of Attachment 'A' to the Employer's Requirements. The contractor shall also provide a fully furnished office of nearly 80 sqm area at its own cost and maintain at its cost two (02) road vehicles (Mahindra Scorpio or similar – alongwith drivers available for 24hrs a day) <b>and 1 steno</b> for use/utilization by LMRC.	Annexure-9, Page 47R1
9	Appendix-1, Employer's Requirement - Appendices, Vol.-3, Page 67	DRAWING LIST	Please refer revised DRAWING LIST.	Annexure-10, Page 67R1 to 67A
10	Item No. 2.1.1 of Schedule-B (NDSR ITEMS-CIVIL), BOQ, Vol.-6, Page 95	Description & Unit of Item 2.1.1 of Schedule-B of BOQ.	Please refer revised description with Technical Specification of motorized rolling shutter (heavy duty), and corrected unit of the item.	Annexure-11, Page 95R1 to 95A
11	Table under Clause 16 of Technical Specifications- Civil & Plumbing, Pg. 138 - 142	Item at S. No. 44 <b>Reinforcement Bars</b> : Sail, RINL, Tata, JSW	Additional Manufacturer's Name added to Item at S. No. 44 <b>Reinforcement Bars</b> : Sail, RINL, Tata, JSW, <u>JSPL</u>	Annexure-12 Page 140R1
12	Volume-5, Tender Drawings	Civil Drawings	Please refer revised Drawings.  The drawings provided here and those in Volume-5 are tender stage drawings for reference pupose. However, actual constructions will be based on approved drawings.	Annexure-13 (17 nos. of drawings)
13	Clause 1.1.2 Key Details of NIT, Vol.-1, Pg. 1	<b>Last date of Reply to Pre-bid Queries &amp; issue of addendum (if any) -</b> 01.10.2019 <b>Date &amp; time of Submission of Tender -</b> 11.10.2019 upto 15:00 Hrs. <b>Date &amp; time of opening of Tender -</b> 11.10.2019 @ 15:30 Hrs	<b>Last date of Reply to Pre-bid Queries &amp; issue of addendum (if any) -</b> 01.10.2019-04.10.2019 <b>Date &amp; time of Submission of Tender -</b> <del>11.10.2019</del> 15.10.2019 upto 15:00 Hrs. <b>Date &amp; time of opening of Tender -</b> <del>11.10.2019</del> 15.10.2019 @ 15:30 Hrs	Annexure-14, Pg. 1 R2

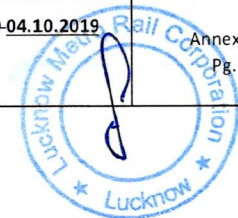

(f) Any further documents which are requested in writing by Employer before submission of the Tender by way of evaluation documents but which are not to form part of the Contract;

(g) Following information shall be furnished:

(A) Civil Engineering Construction works

(i) Extent of participation by each member of the consortium in terms of percentage of the value of the proposed Contract.

Member	% of participation
--------	--------------------

A

B

C

(ii) The tenderer should supply the following information, separately for each member of the consortium.

(a) Maximum value of Civil Engineering construction works executed in any one year during the last 7 years (in Rs. equivalent).

(b) Value of the commitments and on-going works, on a yearly basis, pertaining to Civil Engineering construction, to be completed during the next **24 18** months from the first date of the month of the tender submission.

Both (a) and (b) should be updated to price level of last day of the month previous to the month in which the tender is submitted by assuming 2% inflation on foreign currency and 5% on Indian currency. For conversion of foreign currency, please refer clause E5.3 of ITT.

C2.4 The Employer may get, from the Government, partial or complete waiver of taxes, royalties, duties, Labour cess, ~~Other~~, and other levies payable to various authorities. The successful tenderer (the contractor) shall maintain meticulous records of all the taxes and duties paid and provide the same quarterly with running bill. In case the waiver becomes effective, the Contractor will be advised on the process to be followed to obtain the refund from the concerned authority. The Contractor shall arrange for the remit of the refund to the Employer. In case of failure by the Contractor to remit such amounts, the same shall be recovered from amounts due for payment to the Contractor.

With the tender submission, the tenderer shall submit the proof of Goods and Service Tax (GST) registration or shall submit an undertaking that he will get registered with tax authorities in case of award of LOA to them.

C2.5 **Tenderers shall quote all prices** as per Clause 11.1.1 of GCC and clause 11.1.1 of SCC.

C 2.6 **The tenderers must note the following:**

a) **Deleted**

b) LMRC project is covered under Project Import chapter 98.01 of Custom Tariff Act according to which only concessional custom duty is payable. The tenderer should avail this benefit.





As regards registration under Project Import, after the award of the contract, LMRC at the written request of a contractor shall facilitate the contractor for obtaining sponsoring / recommendation letter from the Ministry of Urban Development for getting themselves registered for availing Project Import benefits. The responsibility to avail the concessional benefits under Project Import shall solely rest with the contractor. LMRC shall appoint the coordinating officer for the said purpose.

**c) Change in Taxes/Duty :**

The contract price shall not be adjusted to take into account any change in taxes, duties, levies or introduction of any new tax, duty or levy except otherwise mentioned in GCC or SCC till the completion date including the date of extended period of contract.

**d) Goods and Services Tax (GST) is included in the contract price.** The contractor shall maintain details of GST paid to 'Trade and Taxes' department and submit: -

- (i) Monthly Return of GST (GSTR-3B) of the contractor for the relevant period/periods along with detailed statement (GSTR 1 & GSTR 2) and copy of challans in regards to deposit of taxes for LMRC project.
- (ii) Certificate of the Chartered Accountant in regards to turnover of the contractor relating to LMRC project and GST paid/adjusted through Input Tax Credit.

**e) No documents with regard to Custom and Excise duty will be required to be submitted.**

**In view of above, the tenderers are advised to quote the price inclusive of Goods and Services Tax (GST), duties, levies, cess and all other incidental charges required to fulfil the tender conditions including statutory deduction viz., TDS towards Income Tax / GST/ Labour Cess etc. after considering clause C2.4, C2.5 & C2.6 above.**

**Any GST, duties, levies cess, which are required/may be required to be paid by the Employer in the fulfilment of the tender conditions including on reverse charge basis should also be included by the tenderer in the Contract Price.**

**C3 Form of Tender**

The Form of Tender shall be completed and signed by a duly authorised and empowered representative of the Tenderer. If the Tenderer comprises a partnership, the Form of Tender shall be signed by a person who is duly authorised by each member thereof or by authorized signatory of each member. Signatures on the Form of Tender shall be witnessed and dated. Copies of relevant powers of attorney shall be attached.

**C4 Outline Quality Plan**

The Tenderer shall submit **Appendix-3** of FOT to form part of his Tender an Outline Quality Plan illustrating the intended means of compliance with Appendix 6 of the Employer's Requirements (Volume 3) and setting out in summary form an adequate basis for the development of the more detailed document required under Clause 18 of the SCC. The Outline Quality Plan shall contain sufficient information to demonstrate clearly the proposed method of achieving the Tenderer's quality objectives with regard to the requirements of the Contract.

**C5 Outline Safety, Health and Environment Plan**

**C5.1** The Tenderer shall submit **Appendix-4** of FOT to form part of its Tender an Outline Safety, Health and Environment Plan which shall contain sufficient information to demonstrate clearly the Tenderer's proposals for achieving effective and efficient safety, health & environment procedures. The Outline Safety, Health and Environment Plan should include an outline of the safety procedures and regulations to be developed and the mechanism by which they will be implemented for ensuring safety as required by relevant clauses of Tender Documents.

**C5.2** The Outline Safety, Health and Environment Plan shall be headed with a formal statement of policy in relation to safety, health & environment and shall be sufficiently informative to define the Tenderer's safety plans and set out in summary an adequate

**CONTRACT LKGG-03 KNPCC-03**  
**Instructions to Tenderers**

**Annexure-6 [As per clause C18.1]**

**FORM OF BANK GUARANTEE FOR TENDER SECURITY**

(To be stamped in accordance with Stamp Act, if any, of the country of issuing bank)

1. KNOW ALL MEN by these presents that we ..... (Name of Bank) having our registered office at ..... (Name of country) (hereinafter called "the Bank") are bound unto Lucknow Metro Rail Corporation Limited (hereinafter called "the Employer") in the sum of Rs. ....for which payment will and truly to be made to the said Employer, the Bank binds itself, its successors and assigns by these presents.
2. WHEREAS.....(Name of Tenderer) (hereinafter called "the Tenderer") has submitted its tender dated\_\_\_\_\_for ..... (Name of the work as per clause 1.1.1 of NIT) hereinafter called the tender.  
AND WHEREAS the Tenderer is required to furnish a Bank Guarantee for the sum of Rs. ....as Tender Security against the Tenderer's offer as aforesaid.  
AND WHEREAS.....(Name of Bank) have, at the request of the Tenderer, agreed to give this guarantee as hereinafter contained.
3. We further agree as follows:
  - a. That the Employer may without affecting this guarantee grant time or other indulgence to or negotiate further with the Tenderer in regard to the conditions contained in the said tender and thereby modify these conditions or add thereto any further conditions as may be mutually agreed upon between the Employer and the Tenderer.
  - b. That the guarantee hereinbefore contained shall not be affected by any change in the constitution of our Bank or in the constitution of the Tenderer.
  - c. That any account settled between the Employer and the Tenderer shall be conclusive evidence against us of the amount due hereunder and shall not be questioned by us.
  - d. That this Guarantee commences from the date hereof and shall remain in force till ..... (date to be filled up) (up to **236 days** from the date of tender).
  - e. That the expression 'the Tenderer' and 'the Bank' herein used shall, unless such an interpretation is repugnant to the subject or context, include their respective successors and assigns.
4. **THE CONDITIONS OF THIS OBLIGATION ARE:**
  - a. if the Tenderer withdraws his Tender during the period of Tender validity specified in the Form of Tender, or





**CONTRACT LKCC-03 KNPCC-03**  
**Instructions to Tenderers**

**Annexure-7 [As per clause F5.1]**

**FORM OF PERFORMANCE SECURITY (GUARANTEE) BY BANK**

1. This deed of Guarantee made this day of ..... (month & year) between Bank of..... (hereinafter called the "Bank") of the one part, and Lucknow Metro Rail Corporation Limited (hereinafter called "the Employer") of the other part.
2. Whereas Lucknow Metro Rail Corporation Limited has awarded the contract for ..... (Name of work as per Clause 1.1.1 of NIT) (hereinafter called the contract) to ..... (Name of the Contractor) hereinafter called the Contractor.
3. AND WHEREAS the Contractor is bound by the said Contract to submit to the Employer a Performance Security for a total amount of Rs.....(Amount in figures and words).
4. Now we the Undersigned ..... (Name of the Bank) being fully authorized to sign and to incur obligations for and on behalf of and in the name of..... (Full name of Bank), hereby declare that the said Bank will guarantee the Employer the full amount of Rs. .... (Amount in figures and Words) as stated above.
5. After the Contractor has signed the aforementioned Contract with the Employer, the Bank is engaged to pay the Employer, any amount up to and inclusive of the aforementioned full amount upon written order from the Employer to indemnify the Employer for any liability of damage resulting from any defects or shortcomings of the Contractor or the debts he may have incurred to any parties involved in the Works under the Contract mentioned above, whether these defects or shortcomings or debts are actual or estimated or expected. The Bank will deliver the money required by the Employer immediately on demand without delay and demur and without reference to the Contractor and without the necessity of a previous notice or of judicial or administrative procedures and without it being necessary to prove to the Bank the liability or damages resulting from any defects or shortcomings or debts of the Contractor. The Bank shall pay to the Employer any money so demanded notwithstanding any dispute/disputes raised by the Contractor in any suit or proceedings pending before any Court, Tribunal or Arbitrator/s relating thereto and the liability under this guarantee shall be absolute and unequivocal.
6. This Guarantee is valid till ..... (The initial period for which this Guarantee will be valid must be for at least Six-months (Six months) longer than the anticipated expiry date of defect liability period as stated in Clause 4.2.1 (i) of the "General Conditions of Contract".)
7. At any time during the period in which this Guarantee is still valid, if the Employer agrees to grant a time extension to the Contractor or if the Contractor fails to complete the Works within the time of completion as stated in the Contract, or fails to discharge himself of the liability or damages or debts as stated under Para 5, above, it is

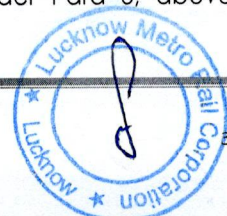

**CONTRACT KNPCC-03**  
**Instructions to Tenderers**

**Annexure 7A [As per clause 11.2.1 & 11.2.2 of GCC]**

**FORM OF BANK GUARANTEE FOR MOBILISATION OF ADVANCE and PLANT & MACHINERY**  
**ADVANCE**

(To be stamped in accordance with Stamp Act of India)

Ref \_\_\_\_\_

Bank Guarantee

Date

Dear Sir,

In consideration of M/s. \_\_\_\_\_ (hereinafter referred as the "Employer", which expression shall, unless repugnant to the context or meaning thereof include its successors, administrators and assigns) having awarded to M/s. \_\_\_\_\_ (hereinafter referred to as the "Contractor", which expression shall unless repugnant to the context of meaning thereof, include its successor, administrators, executors and assigns), a contract by issue of Contract Agreement No. KNPCC-03 dated \_\_\_\_\_ and the same having been unequivocally accepted by the Contractor, resulting in a Contract valued at \_\_\_\_\_ (hereinafter called the "Contract").

and the Employer having agreed to make an advance payment o the Contractor for performance of the above contract amount to \_\_\_\_\_ (in words and figures) as an advance against Bank Guarantee to be furnished by the Contractor.

We \_\_\_\_\_ (Name & Address of Bank) having its Head Office at \_\_\_\_\_ (hereinafter referred to as the Bank, which expression shall unless repugnant to the context of meaning thereof, include its successors, administrators executors and assigns) do hereby unconditionally, irrevocably and without demur guarantee and undertake to pay the Employer immediately on demand any or, all monies payable by the Contractor to the extent of \_\_\_\_\_ as aforesaid at any time upto \_\_\_\_\_ @ \_\_\_\_\_ without any demur, reservation, context, recourse or protest and or without any reference to the consultant. Any such demand made by the Employer on the Bank shall be conclusive and binding notwithstanding any difference between the Employer and the Contractor or any dispute pending before any Court, Tribunal, Arbitrator or any other authority. We agree that the Guarantee herein contained shall be irrevocable and shall continue to be enforceable till the Employer discharges this guarantee.

The Employer shall have the fullest liberty without affecting in any way the liability of Bank under this Guarantee, from time to time to vary the advance or to extend the time for performance of the contract by the Contractor. The Employer shall have the fullest liberty without affecting this guarantee, to postpone from time to time the exercise of any powers vested in them or of any right which they might have against the Employer and to exercise the same at any time in any manner, and either to enforce or to forebear in enforce any convents, contained or implied, in the Contract between the Employer and Contractor any other curse or remedy or security available to the Employer. The bank shall not be relieved of its obligation under these presents by any exercise by the Employer of its liberty with reference to the matters aforesaid or any of them or by reason of any other act or

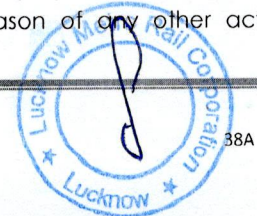



forbearance or other acts of omission or commission on the part of the Employer or any other indulgence shown by the Employer or by any other matter or thing whatsoever which under the law would but for this provision have the effect of relieving the Bank.

The Bank also agrees that the Employer at his option shall be entitled to enforce this Guarantee against the Bank as a principal debtor, in the first instance without proceeding against the Contractor and notwithstanding any security or other guarantee that the Employer may have in relation to the Contractor's liabilities.

Notwithstanding anything contained herein above the liability under this guarantee is limited to \_\_\_\_\_ and it shall remain in force upto and including \_\_\_\_\_ @ \_\_\_\_\_ and shall be extended from time to time for such period (not exceeding one year) as may be desired by M/s. \_\_\_\_\_ on whose behalf this guarantee has been given.

Dated this \_\_\_\_\_ day of \_\_\_\_\_ 20\_\_\_\_ at \_\_\_\_\_

WITNESS

\_\_\_\_\_  
(Signature)

(Name)

(Office Address)

\_\_\_\_\_  
(Signature)

(Name)

Designation (with Bank Stamp)

Attorney as Power of

Attorney No.

Date

Strike out, whichever is not applicable.

@ The date will be ninety (90) days after the date of completion of contract.

Notes:

1. The stamp papers of appropriate value shall be purchased in the name of the Bank, who issues the 'Bank Guarantee'.
2. The 'Bank Guarantee' shall be from the Scheduled Commercial Bank based in India, acceptable to Employer.



24. **Clause 10.1**

**Defect liability period**

Following is added to Clause 10.1 of GCC.

The Defect liability period (DLP) shall be 52 weeks. If Taking over Certificate is issued in parts, the defect liability period for different parts of works shall start from the date of issue of Taking Over Certificate for that part of work.

**Work by persons other than the Contractor.**

If by reason of any accident or failure or other event occurring to, in, or in connection with the Works any remedial or other work shall, in the opinion of the Engineer, be urgently necessary and the Contractor is unable or unwilling at once to do such remedial or other work, the Engineer may authorise the carrying out of such remedial or other work by a person other than the Contractor. If the remedial or other work so authorised by the Engineer is work, which, in the Engineer's opinion, the Contractor was liable to do under the defect liability period Contract, all expenses properly incurred in carrying out the same shall be recoverable by the Employer from the Contractor, provided that the Engineer shall, as soon after the occurrence of any such emergency as may be reasonably practicable, notify the Contractor thereof in writing.

25. **Clause 11.1.1**

**The Contract Price Inclusion/Exclusion**

*Sub Clause 11.1.1 (i) of GCC is replaced as under:*

(a) The contract price, subject to any adjustment thereto in accordance with the contract shall be all inclusive (including all taxes, duties, royalties etc.) including Goods and Service Taxes (GST).

**Any GST, duties, levies cess, which are required/may be required to be paid by the Employer in the fulfilment of the tender conditions including on reverse charge basis should also be included by the tenderer in the Contract Price.**

**(b) The contract price shall be quoted in Indian Rupees Only.**

~~(c) Taxes and duties paid to the sub-vendors shall not be paid separately and therefore are to be included in the price.~~

~~(d) Tenderers shall submit an undertaking that neither they nor their sub-contractors / sub-vendors shall avail the deemed export benefit as the same shall be availed directly by LMRC and retained.~~

26. **Clause 11.1.3**

**Adjust in Contract Price**

*Clause 11.1.3 of GCC is replaced as under*

Following provisions shall be applicable for this contract:-

**(i) Adjustment in contract price on account of inflation shall be as under:-**

**No adjustment in contract price on account of inflation shall be done for E & M works (Schedule-E of Volume -6).**

The rates as per the accepted Bill of Quantities, shall be applicable till the completion of the Work and will be varied only to the extent of permissible price variation under this Clause. However, this adjustment shall be to the extent that full compensation for any rise or fall in costs to the Contractor is not





provided the same have reached the site, or in the case of new items meant specifically for the works, firm purchase order has been placed and the invoices received. The plant and machinery shall be valued by the Engineer as follows:

- a. New items: 80% of purchase price
- b. Used items in working order: 80% of the depreciated value as assessed by the Engineer
- c. Items valued at less than: Not to be considered Rs. 25,000 per unit.

The total advance for Plant and Machinery shall be limited to 5% of the total Contract Value of BOQ/Price document and shall be paid against 12 acceptable Bank Guarantees of equal amount from a Schedule Commercial Bank of India.

29. **Clause 11.3.3**

**Recovery of Advances /Provisional Payment**

*Following is added below item (c) in Clause 11.3.3 of GCC:*

In case the recovery of the provisional payment made against at site could not be made as per Clause 11.3.3 (c) of GCC due to any reason, interest shall be charged at rate equal to prime lending rate of SBI plus 2% per annum or 10% per annum whichever is higher

30. **Clause 11.6**

**Interim Payment / Running Account Payment**

After preliminary scrutiny and certification by Engineer, payment of 80% of the certified interim amount/Running account Payment shall be made by the Employer within 7 days. The amount certified shall account for all deductions, including statutory deductions, recoveries for advances and any amounts due from the Contractor. The balance 20% shall be paid within 21 days, from the date of preliminary certification of the bill by the Engineer.

**Proper GST invoice should be submitted as per taxation laws to facilitate payment.**

31. **Clause 11.17**

**Withholding And Lien For Sums Claimed**

In addition to the entitlement of the employer as per Clause 11.17 of GCC, the employer shall have lien over all or any money that may become due and payable to the Contractor under the Contract, and / or over the deposit of Performance Security or other amount or amounts made under the Contract and which may become payable to the contractor.

32. **Clause 12.0**

**Variations**

**(C) Day work**

For payment of extra items, the Engineer may decide to pay on the basis of 'Day Work' concept instead of paying as per





All of the foregoing documents, together with this Contract Agreement, are referred to herein as the Contract Documents. Also incorporated into these Contract Documents, and made part hereof, are all codes, standard specifications, and similar requirements that are referred to therein. In the event of a conflict, ambiguity or discrepancy between the contents of the Contract Documents, the order of precedence shall be according to the General Conditions of Contract.

Performance Bank Guarantees nos. .... and ..... for ` ..... validity & claim up to ..... and amendment dated ..... and ..... issued by ..... and confirmed by ..... vide their letter no. .... in reference to LMRC letter no. ....

**Clause 2 – Obligation of the Contractor:**

The Contractor agrees, subject to the terms and conditions of the Contract Documents, to perform efficiently and faithfully all of the work and to design and build the ..... and other facilities requisite for or incidental to the successful completion of the Works and in carrying out all duties and obligations imposed by the Contract Documents.

**Clause 3 – Obligation of the Employer:**

The Employer agrees, subject to the terms and conditions of the Contract Documents, to pay the Contractor the amount specified, and at the rates and terms and in the manner set forth in the Contract Documents.

**Clause 4 – Value of Work and Completion Time:**

The Employer agrees to pay for the total cost of the Works and the Contractor agrees to accept the sums mentioned below in the following currencies, to be the total cost for the Work carried out by him as part of his obligations, responsibilities and liabilities under and according to the provisions and obligations imposed on him by the Contract.

(i) ..... (Rupees ..... only); and

**The above amounts include all taxes, duties, royalties, GST and other levies etc. and including all taxes, duties, cess, royalties, GST and other levies payable by the Employer under reserve charge basis or otherwise, for the fulfillment of the Contract obligations.**

The Contractor shall complete the Works within ..... months from the date stipulated in the Letter of Acceptance No. .... ( including Notice to Proceed.)

**Clause 5 – Notices:**

All notices called for by the terms of the Contract Documents shall be in writing in the English language and shall be delivered by hand or by registered mail, acknowledgement due, to the parties' addresses given below. All notices shall be deemed to be duly made when received by the party to whom it is addressed at the following addresses or such other addresses as such party may subsequently notify to the other:





on the Site. The Contractor shall comply with the requirements of Attachment 'A' to the Employer's Requirements. The contractor shall also provide a fully furnished office of nearly 80 sqm area at its own cost and maintain at its cost two (02) road vehicles (Mahindra Scorpio or similar – alongwith drivers available for 24hrs a day) **and 1 steno** for use/utilization by LMRC.

#### LATRINES AND WASHPLACES

- i. The Contractor shall provide latrines and wash places for the use of its personnel and all persons who will be on the Site. The size and disposition of latrines and wash places shall accord with the numbers and dispositions of persons entitled to be on the Site, which may necessitate their location on structures and, where necessary there shall be separate facilities for males and females. The capacities and layout shall be subject to approval of the Engineer. The Contractor shall arrange regular disposal of effluent and sludge in a manner that shall be in accordance with local laws/ regulations.
- ii. The Contractor shall be responsible for maintaining all latrines and wash places on the Site in a clean and sanitary condition and for ensuring that they do not pose a nuisance or a health threat. The Contractor shall also take such steps and make such provisions as may be necessary or directed by the Engineer to ensure that vermin, mosquito breeding etc. are at all times controlled.

#### SITE UTILITIES AND ACCESS

- i. The Contractor shall be responsible for providing water, electricity, telephone, sewerage and drainage facilities for contractor's site offices, structures and buildings and for all site laboratories in accordance with Appendix 7 to these Employer's Requirements and all such services that are necessary for satisfactory performance of the Works. The Contractor shall make all arrangements with and obtain the necessary approval from the relevant civil and utility authorities for the facilities.

The contractor shall be responsible for provision of power supply for his works including for launching girder and the like .The Employer can not guaranty provision of adequate, continuous power supply however assistance will be given in obtaining the necessary permissions for site generators and the like.

- ii. Access roads and parking areas shall be provided within the Site as required and shall be maintained in a clean, acceptable and stable condition. For lengths of roadway longer than 100 m and where vehicle movements exceed one hundred (100) movements/day and heavy commercial vehicle are to ply the Contractor shall provide paved surfacing of adequate thickness and quality to the satisfaction the Engineer.

#### ASSISTANCE TO ENGINEER - Deleted

Any operation of the Works that interferes with the checking of lines and levels shall be temporarily suspended at the request of the Engineer until the checking is complete.



## APPENDIX 1

### DRAWING LIST

The Tender Documents contains a set of reference/Tender drawings that are applicable to the Contract Works. The Tenderer shall incorporate into the Tender only those drawings from that set which amplify aspects of the Contractor's Technical Proposals. General information drawings will not be included in the Contract.

#### Drawings provided in Volume-5 : Tender Drawings.

S.No.	DESCRIPTION	DRAWING NO.
<b>Civil</b>		
1	Site Layout Plan	
2	Ground Floor Plan	
3	First Floor Plan	
4	Second Floor Plan	
<b>Civil - Structural</b>		
5	List of Structural Tender Drawings of Buildings.	KNPDD01-TDR-DP1-STR-DWG-92249-R0
6	Admin/Workshop, Column Layout Plan	KNPDD01-TDR-DP1-STR-DWG-92250-R0
7	Admin/Workshop, Framing Plan at Plinth Level	KNPDD01-TDR-DP1-STR-DWG-92251-R0
8	Admin/Workshop, Framing Plan at First Floor Level	KNPDD01-TDR-DP1-STR-DWG-92252-R0
9	Admin/Workshop, Framing Plan at Second Floor Level	KNPDD01-TDR-DP1-STR-DWG-92253-R0
10	Admin/Workshop, Framing Plan at Roof Level & Mummtly Level	KNPDD01-TDR-DP1-STR-DWG-92254-R0
11	Time & Security Office, Foundation Column Layout & Plinth & Roof Level Framing Plan	KNPDD01-TDR-DP1-STR-DWG-92255-R0
12	Pit Wheel Lathe, Foundation, Column Layout & Plinth Level Framing Plan	KNPDD01-TDR-DP1-STR-DWG-92256-R0
13	Stabling Shed, Foundation Column Layout & Plinth Framing Plan	KNPDD01-TDR-DP1-STR-DWG-92257-R0
<b>Civil - Architectural</b>		
14	List of Architectural Tender Drawings of Buildings.	KNPDD01-TDR-DP1-ARC-LIS-91350-R0
15	Site Plan	KNPDD01-TDR-DP1-ARC-PLN-91351-R0
16	Workshop, DCC, Admin Cum OCC Building – Ground Level Plan	KNPDD01-TDR-DP1-ARC-PLN-91355-R0
17	Workshop, DCC, Admin Cum OCC Building – First Level Plan	KNPDD01-TDR-DP1-ARC-PLN-91356-R0
18	Workshop, DCC, Admin Cum OCC Building – Second Level Plan	KNPDD01-TDR-DP1-ARC-PLN-91357-R0
19	Workshop, DCC, Admin Cum OCC Building – Roof Level Plan	KNPDD01-TDR-DP1-ARC-PLN-91358-R0
20	Workshop, DCC, Admin Cum OCC Building – Upper Roof Level Plan	KNPDD01-TDR-DP1-ARC-PLN-91359-R0
21	Pit Wheel Lathe - Ground & Roof Level Plan	KNPDD01-TDR-DP1-ARC-PLN-91375-R0





**Tender KNPC-03:** Civil, PEB and E&M works for construction of depot cum workshop, including structural, architectural, plumbing, drainage, external development, road works, electrical, mechanical, VAC, fire fighting, fire detection etc. at Govt. Polytechnic Depot for IIT Kanpur to Naubasta Corridor-1 of Kanpur Metro.

**Annexure-10**  
Page 2 of 2

22	Pit Wheel Lathe – Elevation & Section	KNPDD01-TDR-DP1-ARC-DWG-91376-R0
23	Time & Security Office - Plans, Elevation & Section	KNPDD01-TDR-DP1-ARC-DWG-91385-R0
24	Watch Tower - Plan & Section	KNPDD01-TDR-DP1-ARC-DWG-91395-R0
<b>Electrical</b>		
1	Site Plan – LV Cable Routing layout (Sheet 1 & 2)	KNPDD01-TDR-DP1-ELS-PLN-93108 KNPDD01-TDR-DP1-ELS-PLN-93109
2	Main Electrical SLD Sheet (1,2,3 & 4)	KNPDD01-TDR-DP1-ELS-DGM-93101 KNPDD01-TDR-DP1-ELS-DGM-93102 KNPDD01-TDR-DP1-ELS-DGM-93103
3	Site Plan – External Lighting Sheet 1 & 2	KNPDD01-TDR-DP1-ELS-PLN-93105 KNPDD01-TDR-DP1-ELS-PLN-93106
4	Schematic Diagram for firefighting systems	KNPDD01-TDR-DP1-FPS-DGM-93702
5	Schematic Diagram for Fire alarm system	KNPDD01-TDR-DP1-FPS-DGM-93701
6	VAC Schematic Diagram	KNPDD01-TDR-DP1-VAC-DGM-93535

**Drawings at S.No. 1 to 4 & S.No. 14 to 24 above are to be superceded with below listed Drawings provided as Annexure-13 in Addendum-01. Structural drawing will be based on below listed Architectural drawings & will be issued at detailed design stage.**

S.No.	DESCRIPTION	DRAWING NO.
1	Site Layout Plan	KNPDD01-TDR-DP1-ARC-PLN-91101-R0
2	Administrative building Ground Floor Plan	KNPDD01-TDR-DP1-ARC-PLN-91201-R0
3	Administrative building First Floor Plan	KNPDD01-TDR-DP1-ARC-PLN-91202-R0
4	Administrative building Second Floor Plan	KNPDD01-TDR-DP1-ARC-PLN-91203-R0
5	Workshop/DCC & Admin Cum OCC Building - Roof Level Plan	KNPDD01-TDR-DP1-ARC-PLN-91204-R0
6	Administrative building Upper Roof Level Plan	KNPDD01-TDR-DP1-ARC-PLN-91205-R0
7	Administrative building Elevations – 1&2	KNPDD01-TDR-DP1-ARC-DWG-91206-R0
8	Administrative building Elevations – 3,4 & Section-B,C	KNPDD01-TDR-DP1-ARC-DWG-91207-R0
9	Administrative building Sections - A & D	KNPDD01-TDR-DP1-ARC-DWG-91208-R0
10	Pit Wheel Lathe - Ground Floor Plan, Roof Level Plan, Elevations - 1,2 & Section-A	KNPDD01-TDR-DP1-ARC-PLN-91301-R0
11	Auto Coach Washing Plant – General Arrangement Drawing – Sections : BB', CC', EE', FF' & Details – A,B	KNPDD01-TDR-DP1-ARC-PLN-91401-R0
12	Auto Coach Washing Plant – General Arrangement Drawing – Plan & Elevation – A	KNPDD01-TDR-DP1-ARC-PLN-91402-R0
13	Auto Coach Washing Plant – Plan & Sections – A, B, C	KNPDD01-TDR-DP1-ARC-PLN-91403-R0
14	Auto Coach Washing Plant – Elevations – 1,2,3,4	KNPDD01-TDR-DP1-ARC-PLN-91404-R0
15	UG Tank & Pump Room - Plans, Elevation & Section	KNPDD01-TDR-DP1-ARC-PLN-91501-R0
16	Watch Tower - Plan & Section	KNPDD01-TDR-DP1-ARC-PLN-91601-R0
17	Time & Security Office - Plans, Elevation-1 & Section-A,B	KNPDD01-TDR-DP1-ARC-PLN-91701-R0

**Note :** Above drawings are tender stage drawings for reference pupose. However, actual constructions will be based on approved drawings.





S. No.	Description	Unit	Quantity	Rate (INR)	Amount (Rs.)
	Width x 1550mm Depth, which includes 600mm door size width).				
1.1.2	Toilet Cubicle I-Shape (Front Partition) with standard dimension of 2000-2100mm Height x 1000mm Width which includes 600mm door size width).	each	9.00	32,298.07	290682.63
	Total of Wood Work				813493.23
2	STEEL WORK				
2.1	Motorise Rolling Shutters				
2.1.1	<p>Providing and fixing motorized rolling shutter (heavy duty), curtain made of single skinned Galvalume stell laths as per IS6248 with natural finish, partial bright steel with one coat of grey epoxy primer by spray with 900 mm grill in height at eye level, pressed Galvalume steel hood and motor cover with natural finish, wind lock-storm anchors, CE certified CRS compact gear P.R.C. make in direct driver operator and three station push button with deadman control.</p> <p><b>Technical Specification should be as follow:</b>  <u>Rolling Curtain: Constructed from single skinned galvalume, bright steel laths and is retained by interlocking with each other.</u>  <u>Surface: Galvalume with natural finish, Partial Bright Steel with one coat of grey epoxy primer by spray</u>  <u>Material Thickness: 1.2mm for clear width &gt; 3.5m &amp; 0.9mm for clear width ≤ 3.5m as per IS 6248 laths, 8.0mm</u>  <u>Curtain Weight: 15.5 kg/m2 approx</u>  <u>Structure Shape: Curved, Honeycomb</u>  <u>Support Brackets: Mild Steel with one coat of grey epoxy primer by spray</u>  <u>Shaft: Shaft is manufactured from mild steel tube of suitable outside diameter and wall thickness to suit the shutter application and is unsprung</u>  <u>Finish: One coat of grey epoxy primer by spray</u>  <u>Side Guides: 2.0mm thick heavy duty TG Galvanised Steel</u>  <u>Finish: One coat of grey epoxy primer by spray</u>  <u>Wind lock-Storm anchors: Included</u></p>	Each <u>sqm</u>	300.00	12550.63	3765188.55





S. No.	Description	Unit	Quantity	Rate (INR)	Amount (Rs.)
	<p><b>Hood &amp; Motor Cover: 0.9mm thick Pressed galvalume steel hood box complete with reinforced bracket as required to suit the shutter width.</b>  <b>Finish: Natural Finish</b>  <b>Bottom Profile: Bend-resistant Galvanised steel profile for additional strength.</b>  <b>Finish: One coat of grey epoxy primer by spray</b>  <b>Locking arrangement: Shoot Bolt Arrangement</b>  <b>Seals: Optional on side guides &amp; bottom</b>  <b>Surface with protective paint: Optional</b>  <b>CE Certified CRS Compact Gear P.R.C. Make Indirect Drive Operator</b>  <b>Drive Unit: Indirect drive operator. System power supply wired with industrial plug</b>  <b>Safety mechanism: Patented safety mechanism for chain failure with inbuilt limit switches</b>  <b>Control Switch: Three station push button with deadman control</b>  <b>Emergency manual operation: Emergency operation by means of chain</b>  <b>Optional Accessory: Additional three station push button</b></p> <p>Cost is inclusive of all materials and labour complete (curtain, grill, hood, motor, motor cover, anchors, gears, push button, deadman control and any other if required).</p>				
	Total of Steel Work				3765188.55
3	STONE WORK				
3.1	Deduction in rate of Item No. 11.56 of DSR-2018 for lighter shade granite 18 mm thick (Jeerawal White, China White, etc.) approved as per engineer-in-charge.	sqm	4,000.00	-581.80	-2327200.00
3.2	Providing and fixing 18 mm thick Polished Granite Stone cladding work for wall lining over 12 mm thick bed of cement mortar 1:3 (1 cement : 3 coarse sand) and cement slurry @ 3.3 kg/sqm including pointing in white cement complete as per the requirement of the engineer-in-charge.	sqm	500.00	4435.35	2217675.00





**Tender KNPC-03:** Civil, PEB and E&M works for construction of depot cum workshop, including structural, architectural, plumbing, drainage, external development, road works, electrical, mechanical, VAC, fire fighting, fire detection etc. at Govt. Polytechnic Depot for IIT Kanpur to Naubasta Corridor-1 of Kanpur Metro.

**Annexure-12**

29	Modified Bituminous Membrane roof water proofing	Super Thermolay, Polylex of STP, "Lotus-3" of the Structural Waterproofing, FORSOC, SIKA, Kryton Buildmat Cc, MBT.
30	Emulsion Paints	ICI Dulux, Acro Paints, Asian, Berger, Nerolac, Jenson & Nicholson, Shalimar paints.
31	Synthetic Enamel	ICI Dulux, Berger, Asian, Nerolac, Jenson & Nicholson, Acro Paints, Shalimar paints.
32	Textured Paints	Spectrum/Unitile/ Heritage, Dulux, Asian, Burger, Ultratech
33	Polyurethane Paint	MRF/NEROLAC
34	Wall care putty	J.K White Cement Works, Birla putty, unistone, Shalimar, gyproc wall putty (saint gobain)
35	Aluminium Composite panel	Alucobond, Alpolic, Alstone, AluDecor, Alstrong, Eurobond
36	Frameless Glass Partition Fixtures	Droma, Hafele, Doorset, Dline, Insta Hardware, HARDWYN
37	Epoxy	FOSROC, SIKA, QUALCRETE, Araldite, BASF, Kunal Con Chem, CHRYSO, DON Chemicals, STP, Cleantech SA, TAM, CICO, MC-Bauchemie, Pinnacle, Fibrex.
38	Stone cladding champs	Hilti, BOSCH, Fischer, Canon, WURTH
39	Anchor Fasteners	Hilti, BOSCH, Fischer, Canon, Pooja Forgo, TRIXEL, RAWLPLUG, WURTH
40	Sanitary and bath fittings & Fixtures	Jaquar, Kingston, Marc, Kohler, Rocca, Hindware, Parryware
41	Fire resistant paints	Akzo, Noble, PPG, Jotun
42	Construction & Water proofing chemicals, integral water proofing compounds / methods, chloride free plasticiser cum waterproofing compound, floor hardners, silicon impregnation.	Kryton Buildmat, BASF, Chryso, DON, Xypex, Normet India, MYK Schomburg, Penetron, MC Bauchemie (India) Private Ltd. (for Integral Crystalline waterproofing), MAPEI, Asian
43	Cement	Ultra Tech, ACC, Grasim, Gujrat Ambuja, JK Laxmi, Dalmia, Birla Gold
44	Reinforcement Bars	Sail, RINL, Tata, JSW, <b>JSPL</b>
45	Admixtures	FOSROC, MBT, MC Beucheme, Sika, Apex, Pidlife, Polygon, CHRYSO, Choksey, STP, MYK Schomburg, BASF, MAPEI, Kunal Conchem, H&R Jhonson, Asian Lab, CICO, Fairmate, Pinnacle Ultracon, Rheoplast, Normet India, Ado Additives Technologies Ltd., Don Construction Chemicals India Ltd, CAC
46	Structural Steel	TATA, SAIL, ESSAR, Jindal steel and power, JSW, KL steel
47	Welding Electrodes	Advani-Oerlikon, D&H Welding Electrodes,







**GENERAL NOTES :-**

1. ALL DIMENSIONS ARE IN MILLIMETERS & LEVELS ARE IN METERS UNLESS MENTIONED OTHERWISE
2. ALL DIMENSIONS ARE TO BE READ AND NOT TO BE MEASURED
3. THIS DRAWING MUST BE READ IN CONJUNCTION WITH ALL RELEVANT ARCHITECTURAL, STRUCTURAL, PLUMBING, FIRE FIGHTING, ELECTRICAL AND TRAFFIC MANAGEMENT DRAWINGS
4. ANY DISCREPANCIES MUST BE BROUGHT UP TO THE NOTICE OF THE CONSULTANT

REV.	PARTICULARS	DRN.	CHD.	VER.	DATE

**SPECIAL NOTES :-**

1. THESE DRAWINGS ARE ONLY FOR UNDERSTANDING THE SCOPE OF THE WORK. IT IS NOT THE FINAL DOCUMENTATION FOR CONSTRUCTION ACTIVITIES.
2. ALL SUPPORTING MEMBERS REQUIRED FOR CABLE TRAYS, RACEWAYS, ETC ARE INCLUDED IN SQM RATE MENTIONED IN BOQ. NO EXTRA PAYMENT WILL BE MADE FOR ANY SUPPORT MEMBER.

**NOTES :-**

1. SITE PLAN HAS BEEN PROPOSED BASED ON TRACK & BUILDING LAYOUT RECEIVED FROM LMRC THROUGH MAIL DATED 13.09.2019
2. MEP REQUIREMENTS THUS INDICATED ON LAYOUTS SHALL BE DETAILED AT LATER STAGE.
3. THE DRAWINGS HAVE BEEN DEVELOPED WITH RESPECT TO DPR AND LMRC REQUIREMENTS.
4. THE RAIL LEVELS INDICATED ON DRAWINGS ARE SUBJECT TO APPROVAL BY RELEVANT DISCIPLINES/LMRC. +128.6 (+0.00) HAS BEEN TAKEN AS RAIL LEVEL IN THE DRAWINGS.
5. TRACK C/C DIMENSIONS PROVIDED RELATED TO THIRD RAIL SYSTEM REQUIREMENTS. REFER MOM 0-SYST-KNPDD-01-MOM-00010, DATED -07.08.2019. SUBJECT TO APPROVAL OF CONCERN DISCIPLINE/ LMRC.
6. SITE LEVELS SHALL BE UPDATED WITH RESPECT TO SERVICES DESIGN AT LATER STAGE.
7. SIZES OF ALL MEP/ SYSTEMS/TRACKS/OTHER DISCIPLINES, MUST BE VERIFIED BY RELEVANT DISCIPLINES.
8. ALL MATERIALS/ FINISHES THUS MENTIONED ON THE DRAWINGS ARE SUBJECT TO LMRC REVIEW AND APPROVAL.
9. IT IS RECOMMENDED TO PROVIDE SAFETY FENCING AT PLACES WHERE THIRD RAIL TRACTION SYSTEM IS EASILY ACCESSIBLE BY PUBLIC, AS IT CAN BE A LIFE THREATENING HAZARD.
10. TRACK LENGTH FOR PIT WHEEL LATHE TO BE CONFIRMED BY CONCERN DISCIPLINE/ LMRC.

**DETAIL DESIGN CONSULTANT**  
**SYSTRA**  
 SYSTRA MVA CONSULTING (INDIA) PVT. LTD.  
 VATIKA MINDSCAPES, TOWER-B, 12/3,  
 MATHURA ROAD, NH-2, SECTOR-27/D,  
 FARIDABAD, HARYANA-121013  
 PH: 0129 668 5600  
 SUBSIDIARY OF:  
 SYSTRA S.A. - 5 AVENUE DU COQ - PARIS 75009

**IMPLEMENTED BY LMRC**

**NOT IN THE SCOPE OF THIS CONTRACT**

**NOT IN THE SCOPE OF THIS CONTRACT**

**ADMINISTRATIVE BUILDING (WORKSHOP, INSPECTION BAY, DCC, OCC, P-WAY, ETU, WATER TANK & DCO STORE)**

NO OBJECTION FROM LMRC

**NOTICE OF 'NO OBJECTIONS' FROM EMPLOYER**

NOTICE OF NO OBJECTION FROM EMPLOYER IS BEING ACCORDED FOR DESIGN PRINCIPLES HOWEVER THE OVERALL RESPONSIBILITY FOR THE DESIGN ACCURACY LIES WITH THE DETAIL DESIGN CONSULTANT.

REMARKS	DATE	SIGNATURE
DY CA - LMRC REVIEWED & NO OBJECTION MAY BE CONVEYED TO THE CONTRACTOR		
DY CE - LMRC BASED ON STAMPED ABOVE THE NO OBJECTION IS ISSUED FOR EXECUTION PURPOSE		
CPM - LMRC		

PROJECT TITLE  
**LUCKNOW METRO RAIL CORPORATION LTD.**  
 KNPDD01-IIT KANPUR-NAUBASTA CORRIDOR-1  
 (IMPLEMENTED BY LMRC)

PREPARED	NAME	SIGNATURE	DRAWING TITLE
			POLYTECHNIC DEPOT-1
DRAWN BY	P.KUMAR		SITE PLAN
DESIGNED BY	N.A.MALK		
CHECKED BY	N.CHATURVEDI		
APPROVED BY	ASHISH		

SCALE: 1:1000      DATE OF ISSUE: 19-09-19      STAGE: TENDER DRAWING

DRG. NO. KNPDD01-TDR-DP1-ARC-PLN-91101      REV: R0



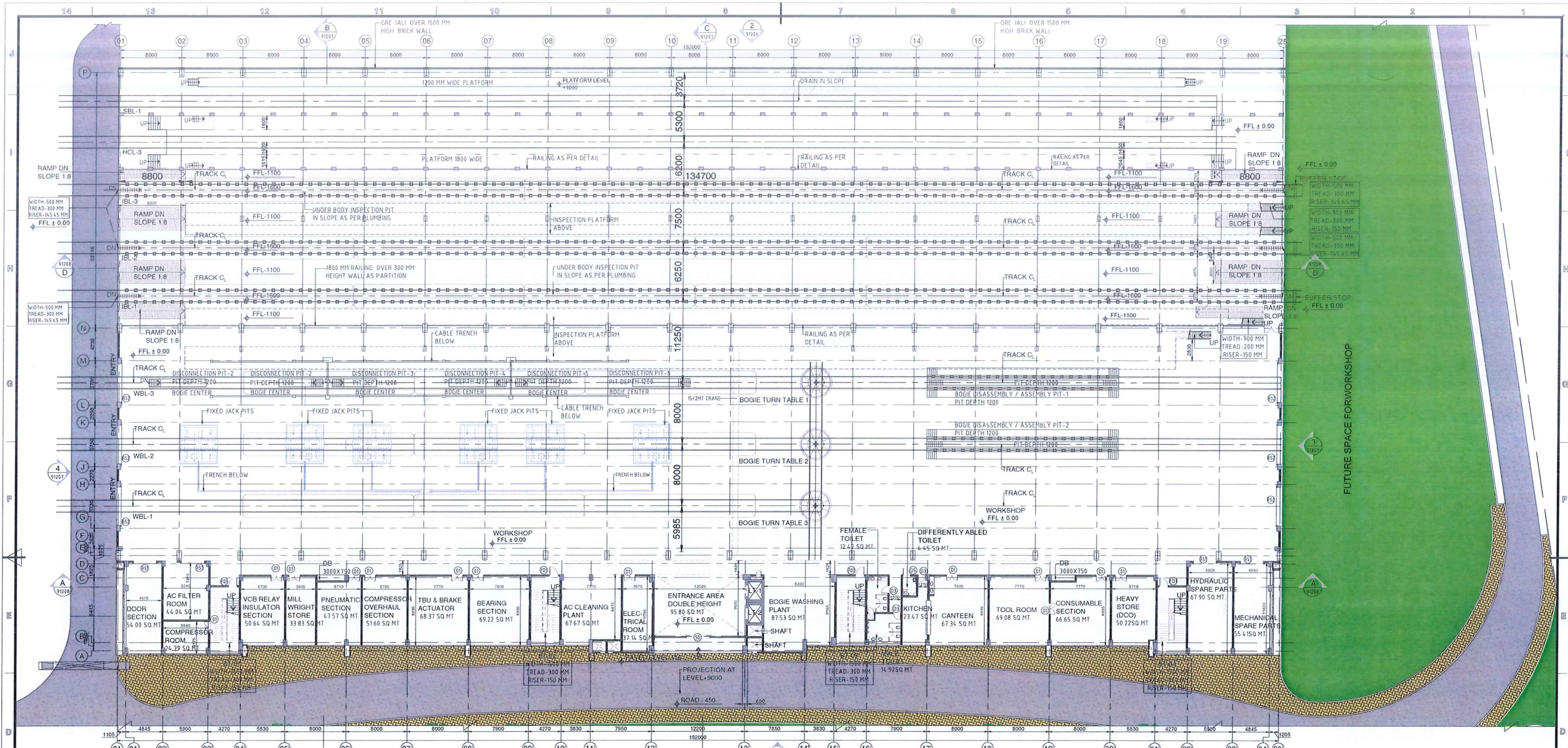

**ABBREVIATIONS :-**  
 LT- LIFT  
 ST- STAIRCASE

**SPECIAL NOTES :-**  
 1. THESE DRAWINGS ARE ONLY FOR UNDERSTANDING THE SCOPE OF THE WORK. IT IS NOT THE FINAL DOCUMENTATION FOR CONSTRUCTION ACTIVITIES.  
 2. ALL SUPPORTING MEMBERS REQUIRED FOR CABLE TRAYS, RACEWAYS, ETC ARE INCLUDED IN SQM RATE MENTIONED IN PEB BOQ. NO EXTRA PAYMENT WILL BE MADE FOR ANY SUPPORT MEMBER.

**GENERAL NOTES :-**  
 1. ALL DIMENSIONS ARE IN MILLIMETERS & LEVELS ARE IN METERS UNLESS MENTIONED OTHERWISE.  
 2. ALL DIMENSIONS MUST BE READ AND NOT TO BE MEASURED.  
 3. THIS DRAWING MUST BE READ IN CONJUNCTION WITH ALL RELEVANT ARCHITECTURAL, STRUCTURAL, PLUMBING, FIRE FIGHTING, ELECTRICAL AND TRAFFIC MANAGEMENT DRAWINGS.  
 4. ANY DISCREPANCIES MUST BE BROUGHT UP TO THE NOTICE OF THE CONSULTANT.

REV.	First Issue	PARTICULARS	PAUMAR	NCHATURVEDI	ASHISH	19-09-19
DRN.	CHD.	VER.	DATE			

**NOTES :-**  
 1. STRUCTURAL ARRANGEMENT PRESENTED ON THE DRAWING IS INDICATIVE, REFER STRUCTURAL DRAWINGS FOR THE SAME.  
 2. ROOF PROFILES AND HEIGHTS SHOWN ON THE DRAWINGS ARE INDICATIVE, SAME SHALL BE DETAILED AT LATER STAGE.  
 3. MEP REQUIREMENTS THUS INDICATED ON LAYOUTS SHALL BE DETAILED AT LATER STAGE.  
 4. LOCATIONS OF FHC, FIRE EXTINGUISHERS AND CUTOFFS WILL BE UPDATED AT LATER STAGES.  
 5. THE DRAWINGS HAVE BEEN DEVELOPED WITH RESPECT TO DPR AND LMRG REQUIREMENTS.  
 6. THE RAIL LEVELS INDICATED ON DRAWINGS ARE SUBJECT TO APPROVAL BY RELEVANT DISCIPLINES/LMRG.  
 7. \*128.6 (+0.00) HAS BEEN TAKEN AS RAIL LEVEL IN THE DRAWINGS.  
 8. ROAD LAYOUT/PEDESTRIAN MOVEMENT/CAR PARKING SHOWN ON THE LAYOUT ARE TENTATIVE, SUBJECT TO APPROVAL BY RELEVANT DISCIPLINE/LMRG.  
 9. TRACK C/C DIMENSIONS PROVIDED RELATED TO THIRD RAIL SYSTEM REQUIREMENTS. REFER MOM 0-SYST-KNPPD-01-MOM-60010, DATED - 07.09.2019  
 10. NO. OF TOILETS AND FIXTURES SHOWN ON THE DRAWINGS ARE INDICATIVE. SHALL BE DETAILED AT A LATER STAGE.  
 11. THE BRACKET SIZES AND LEVELS FOR OVERHEAD CRANES SHALL BE AS VENDOR DETAILS AND DRAWINGS.  
 12. LIFT PIT DEPTH/WELL SIZES SHALL BE FIXED AS VENDOR DETAIL AND DRAWINGS.  
 13. ROOM SIZES, HEIGHTS AND DOOR OPENINGS SHALL BE CONFIRMED BY RELEVANT DISCIPLINES OF ENGINEERING.  
 14. SITE LEVELS SHALL BE UPDATED WITH RESPECT TO SURVEY DRAWINGS AT A LATER STAGE.  
 15. WINDOW/GLAZING OPENING SIZES ARE INDICATIVE, SHALL BE DETAILED AT A LATER STAGE.  
 16. SIZES OF ALL MEP SYSTEMS/TRACKS/OTHER DISCIPLINES, MUST BE VERIFIED BY RELEVANT DISCIPLINES.  
 17. ALL MATERIALS/FINISHES THUS MENTIONED ON THE DRAWINGS ARE SUBJECT TO LMRG REVIEW AND APPROVAL.  
 18. ALL PEB PROFILES/STRUCTURAL SUPPORT SYSTEM SHOWN ON THE DRAWINGS ARE INDICATIVE ONLY. DETAIL TO BE PROVIDED BY THE PEB CONSULTANT.

**SCHEDULE OF OPENINGS**  
 NOTE: ALL SILL AND LEVELS ARE TO BE TAKEN FROM FINISHED FLOOR OF RESPECTIVE ROOM

S.No	Type	Width	Sill Lvl	Level Lvl	Remarks
1	D1	1500	0.00	2100	AS PER SPEC
2	D2	1200	0.00	2100	AS PER SPEC
3	D3	1000	0.00	2100	AS PER SPEC
4	D4	600	300	2100	AS PER SPEC
5	FD	11700	0.00	2100	AS PER SPEC
6	FD1	1200	0.00	2100	AS PER SPEC
7	RS1	3000	0.00	3000	AS PER SPEC
8	RS2	5000	0.00	5000	AS PER SPEC

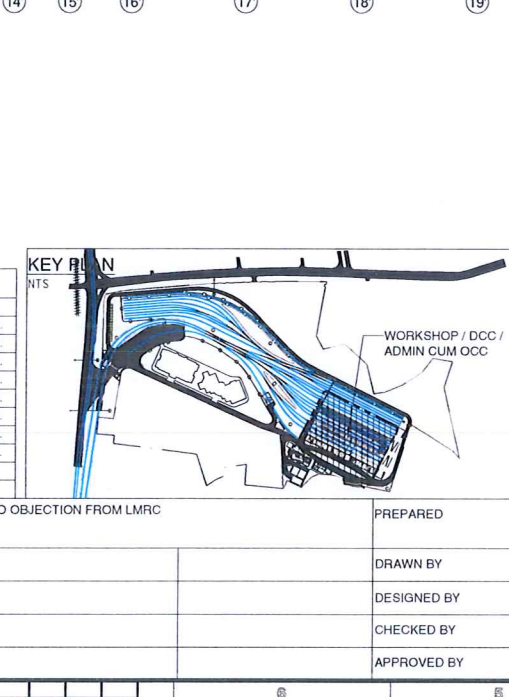

**LEGEND**

SECURITY FENCING	FSBL	FUTURE STABILING LINE	230 MM BRICK WALL
SITE BOUNDARY	SHL	SHUNTING LINE	R.C.C/ COLUMN
TRACK CENTER	PWL	PIT WHEEL LATHE	SECTION/ ELEVATION NAME
WBL WORKSHOP BAY LINE	RW	RECHARGE WELL - 9 NO'S	DRAWING NUMBER
IBL INSPECTION BAY LINE			
HCL HEAVY CLEANING LINE			
SBL STABILING LINE			

**NOTICE OF 'NO OBJECTIONS' FROM EMPLOYER**

NOTICE OF NO OBJECTION FROM EMPLOYER IS BEING ACCORDED FOR DESIGN PRINCIPLES HOWEVER THE OVERALL RESPONSIBILITY FOR THE DESIGN ACCURACY LIES WITH THE DETAIL DESIGN CONSULTANT.

REMARKS	DATE	SIGNATURE
DY CA - LMRG REVIEWED & NO OBJECTION MAY BE CONVEYED TO THE CONTRACTOR		
DY CE - LMRG BASED ON STAMPED ABOVE THE NO OBJECTION IS ISSUED FOR EXECUTION PURPOSE		
CPM - LMRG		

PROJECT TITLE  
**LUCKNOW METRO RAIL CORPORATION LTD.**  
 KNPDD01-IIT KANPUR-NAUBASTA CORRIDOR-1

DRAWING TITLE  
**POLYTECHNIC DEPOT-1**  
**ADMINISTRATIVE BUILDING**  
**GROUND LEVEL PLAN**

SCALE: 1:250  
 DATE OF ISSUE: 19-09-19  
 STAGE: TENDER DRAWING

DRG. NO. KNPDD01-TDR-DP1-ARC-PLN-91201  
 REV. R0

DETAIL DESIGN CONSULTANT  
**SYSTRA**  
 SYSTRA MVA CONSULTING (INDIA) PVT. LTD.  
 VATIKA MINDSCAPES, TOWER-B, 12/3,  
 MATHURA ROAD, NH-2, SECTOR-27/D,  
 FARIDABAD, HARYANA-121013  
 PH: 0129 668 5600  
 SUBSIDIARY OF:  
 SYSTRA S.A. - 5 AVENUE DU COQ - PARIS 75009

NO OBJECTION FROM LMRG

PREPARED  
 DRAWN BY  
 DESIGNED BY  
 CHECKED BY  
 APPROVED BY

NAME  
 SIGNATURE

IMPLEMENTED BY LMRG

LUCKNOW METRO RAIL CORPORATION  
 (IMPLEMENTED BY LMRG)



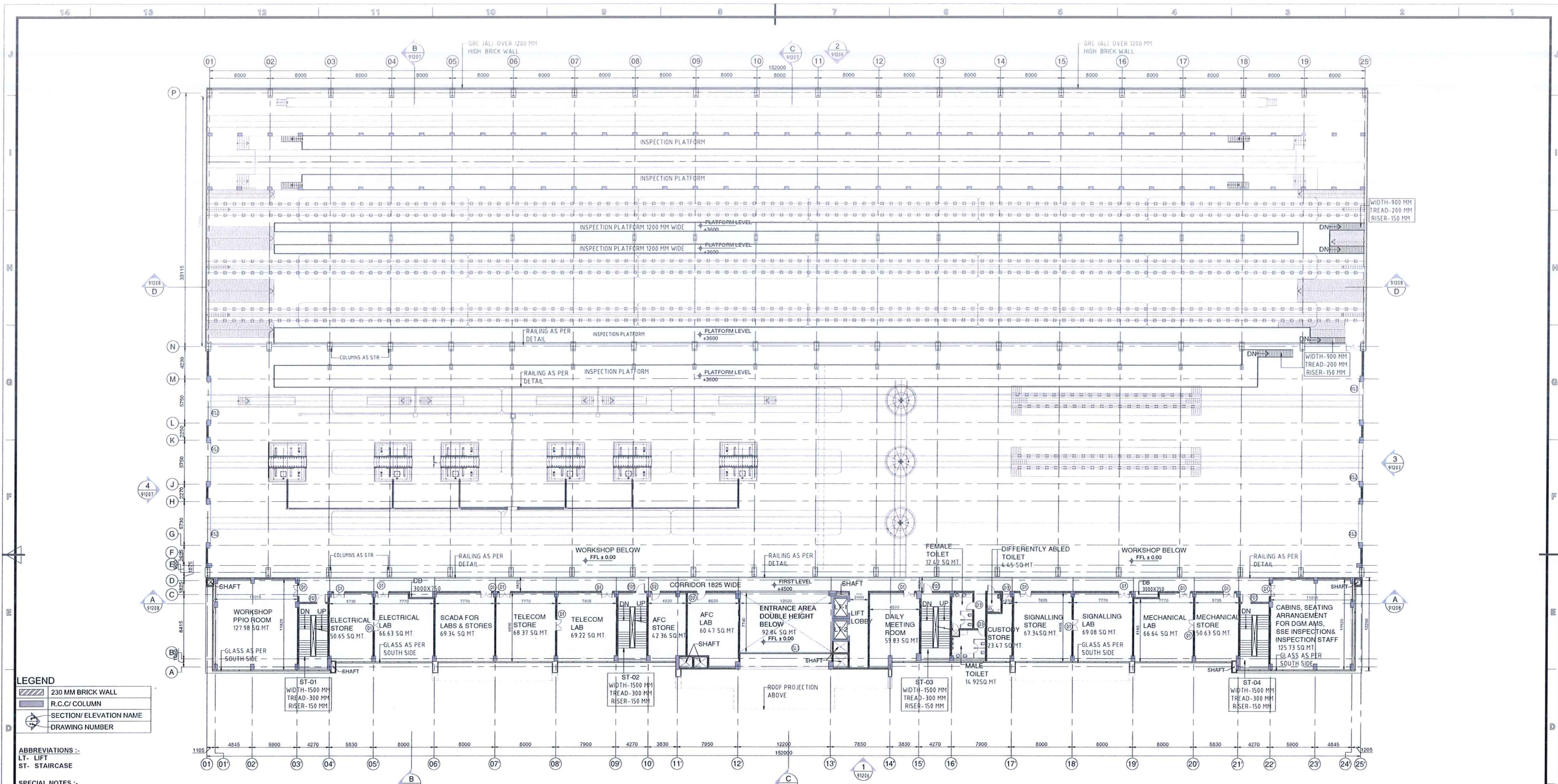

**LEGEND**

	230 MM BRICK WALL
	R.C.C/ COLUMN
	SECTION/ ELEVATION NAME
	DRAWING NUMBER

**ABBREVIATIONS :-**  
 LT- LIFT  
 ST- STAIRCASE

**SPECIAL NOTES :-**

- THESE DRAWINGS ARE ONLY FOR UNDERSTANDING THE SCOPE OF THE WORK. IT IS NOT THE FINAL DOCUMENTATION FOR CONSTRUCTION ACTIVITIES.
- ALL SUPPORTING MEMBERS REQUIRED FOR CABLE TRAYS, RACEWAYS, ETC ARE INCLUDED IN SQM RATE MENTIONED IN BOQ. NO EXTRA PAYMENT WILL BE MADE FOR ANY SUPPORT MEMBER.

**GENERAL NOTES :-**

- ALL DIMENSIONS ARE IN MILLIMETERS & LEVELS ARE IN METERS UNLESS MENTIONED OTHERWISE
- ALL DIMENSIONS ARE TO BE READ AND NOT TO BE MEASURED
- THIS DRAWING MUST BE READ IN CONJUNCTION WITH ALL RELEVANT ARCHITECTURAL, STRUCTURAL, PLUMBING, FIRE FIGHTING, ELECTRICAL AND TRAFFIC MANAGEMENT DRAWINGS
- ANY DISCREPANCIES MUST BE BROUGHT UP TO THE NOTICE OF THE CONSULTANT.

**NOTES :-**

- STRUCTURAL ARRANGEMENT PRESENTED ON THE DRAWING IS INDICATIVE, REFER STRUCTURAL DRAWINGS FOR THE SAME.
- ROOF PROFILES AND HEIGHTS SHOWN ON THE DRAWINGS ARE INDICATIVE, SAME SHALL BE DETAILED AT LATER STAGE.
- MEP REQUIREMENTS THIS INDICATED ON LAYOUTS SHALL BE DETAILED AT LATER STAGE.
- LOCATIONS OF FHC, FIRE EXTINGUISHERS AND CUTOUTS WILL BE UPDATED AT LATER STAGES.
- THE DRAWINGS HAVE BEEN DEVELOPED WITH RESPECT TO DPR AND LMRC REQUIREMENTS.
- THE RAIL LEVELS INDICATED ON DRAWINGS ARE SUBJECT TO APPROVAL BY RELEVANT DISCIPLINES/LMRC. +128.8 (+0.00) HAS BEEN TAKEN AS RAIL LEVEL IN THE DRAWINGS.
- ROAD LAYOUT/PEDESTRIAN MOVEMENT/CAR PARKING SHOWN ON THE LAYOUT ARE TENTATIVE, SUBJECT TO APPROVAL BY RELEVANT DISCIPLINES/LMRC.
- TRACK C/C DIMENSIONS PROVIDED RELATED TO THIRD RAIL SYSTEM REQUIREMENTS. REFER MOM 0-SYST-KNPDD-01-MOM-00010, DATED - 07.08.2019
- NO. OF TOILETS AND FIXTURES SHOWN ON THE DRAWINGS ARE INDICATIVE. SHALL BE DETAILED AT A LATER STAGE.
- THE BRACKET SIZES AND LEVELS FOR OVERHEAD CRANES SHALL BE AS VENDOR DETAILS AND DRAWINGS.
- LIFT PIT DEPTH/WELL SIZES SHALL BE FIXED AS VENDOR DETAIL AND DRAWINGS.
- ROOM SIZES, HEIGHTS AND DOOR OPENINGS SHALL BE CONFIRMED BY RELEVANT DISCIPLINES OF ENGINEERING.
- SITE LEVELS SHALL BE UPDATED WITH RESPECT TO SURVEY DRAWINGS AT A LATER STAGE.
- WINDOW/GLAZING OPENING SIZES ARE INDICATIVE, SHALL BE DETAILED AT A LATER STAGE.
- SIZES OF ALL MEP/ SYSTEMS/TRACKS/OTHER DISCIPLINES, MUST BE VERIFIED BY RELEVANT DISCIPLINES.
- ALL MATERIALS/ FINISHES THIS MENTIONED ON THE DRAWINGS ARE SUBJECT TO LMRC REVIEW AND APPROVAL.
- ALL MEP PROFILES/STRUCTURAL SUPPORT SYSTEM SHOWN ON THE DRAWINGS ARE INDICATIVE ONLY. DETAIL TO BE PROVIDED BY THE PEB CONSULTANT.

**SCHEDULE OF OPENINGS**

NOTE: ALL SILL AND LIFT LEVELS ARE TO BE TAKEN FROM FINISHED FLOOR OF RESPECTIVE ROOM

S.No	Type	Width	S/L Lvl	Lift/Lvl	Remarks
1	D1	1500	0.00	2100	AS PER SPEC.
2	D2	1200	0.00	2100	AS PER SPEC.
3	D3	1000	0.00	2100	AS PER SPEC.
4	D4	600	300	2100	AS PER SPEC.
5	SD	11700	0.00	2100	AS PER SPEC.
6	FD1	1200	0.00	2100	AS PER SPEC.
7	RS1	3000	0.00	3000	AS PER SPEC.
8	RS2	5000	0.00	5000	AS PER SPEC.

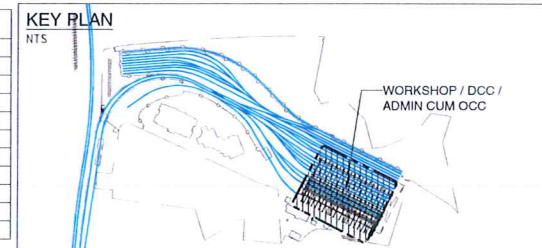

**NOTICE OF 'NO OBJECTIONS' FROM EMPLOYER**

NOTICE OF NO OBJECTION FROM EMPLOYER IS BEING ACCORDED FOR DESIGN PRINCIPLES HOWEVER THE OVERALL RESPONSIBILITY FOR THE DESIGN ACCURACY LIES WITH THE DETAIL DESIGN CONSULTANT.

REMARKS	DATE	SIGNATURE
DY CA - LMRC REVIEWED & NO OBJECTION MAY BE CONVEYED TO THE CONTRACTOR		
DY CE - LMRC BASED ON STAMPED ABOVE THE NO OBJECTION IS ISSUED FOR EXECUTION PURPOSE		
CPM - LMRC		

PROJECT TITLE  
**LUCKNOW METRO RAIL CORPORATION LTD.**  
 KNPDD01-IIT KANPUR-NAUBASTA CORRIDOR-1 (IMPLEMENTED BY LMRC)

NO OBJECTION FROM LMRC	PREPARED	NAME	SIGNATURE	DRAWING TITLE
				<b>POLYTECHNIC DEPOT-1</b>
				<b>ADMINISTRATIVE BUILDING</b>
				<b>FIRST LEVEL PLAN</b>
				SCALE 1:250 DATE OF ISSUE 19-09-19
				DRG NO. KNPDD01-TDR-DP1-ARC-PLN-91202

REV.	NO.	DATE	BY	CHKD.	VER.	DATE

**DETAIL DESIGN CONSULTANT**  
**SYSTRA MVA CONSULTING (INDIA) PVT. LTD.**  
 VATIKA MINDSCAPES, TOWER-B, 12/3,  
 MATHURA ROAD, NH-2, SECTOR-27/D,  
 FARIDABAD, HARYANA-121013  
 PH. 0129 668 5600  
 SUBSIDIARY OF:  
 SYSTRA S.A. - 5 AVENUE DU COQ - PARIS 75009

NO OBJECTION FROM LMRC

PREPARED BY: P. KUMAR

DRAWN BY: P. KUMAR

DESIGNED BY: N.A. MALIK

CHECKED BY: N. CHATURVEDI

APPROVED BY: ASHISH

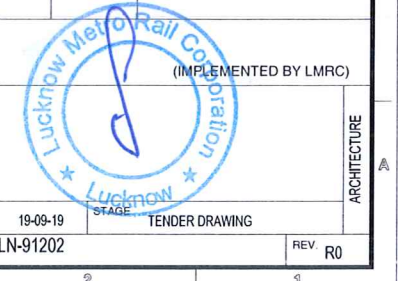

ARCHITECTURE



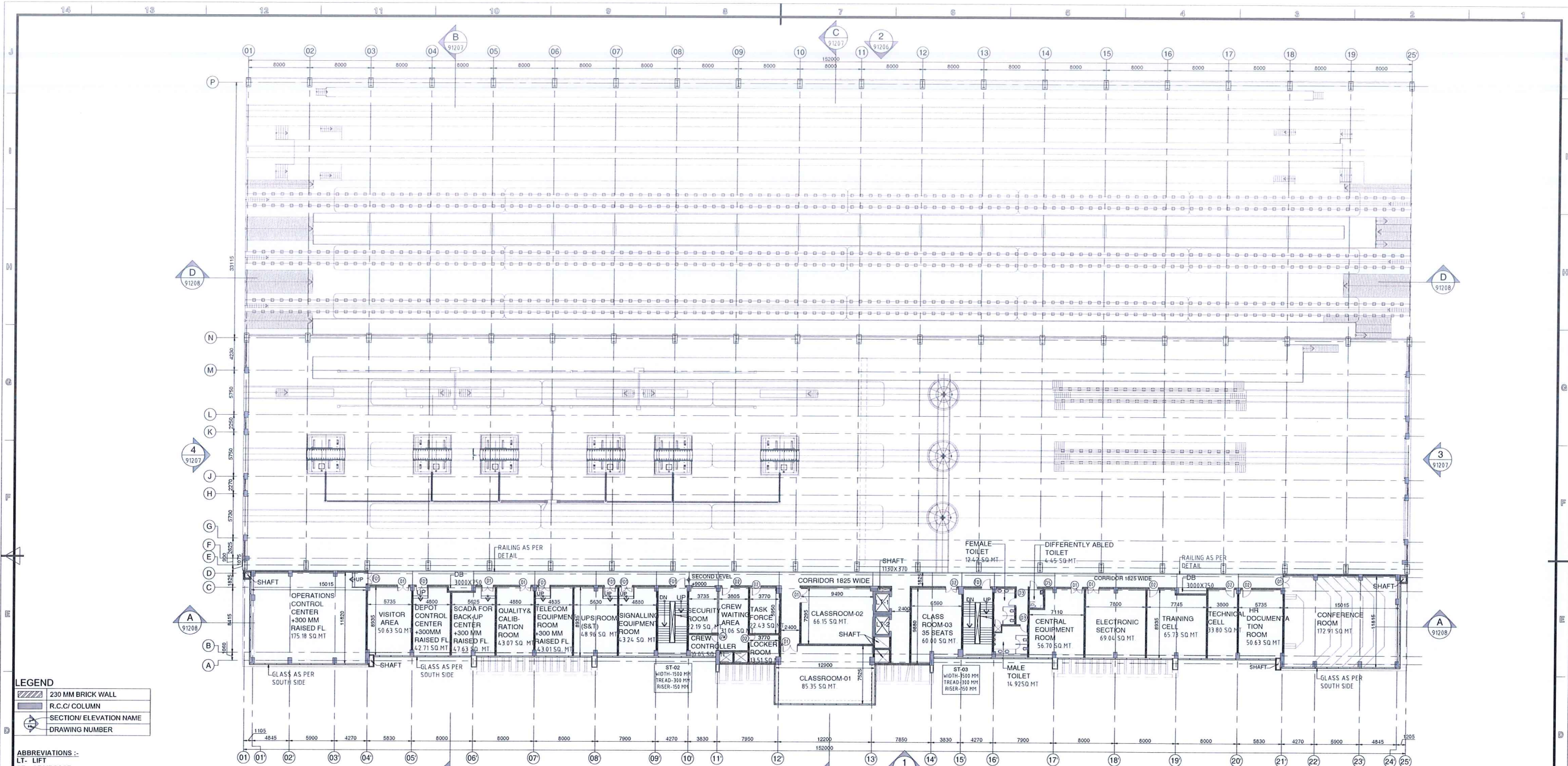

**LEGEND**

	230 MM BRICK WALL
	R.C.C/ COLUMN
	SECTION/ ELEVATION NAME
	DRAWING NUMBER

**ABBREVIATIONS :-**  
 LT- LIFT  
 ST- STAIRCASE

**SPECIAL NOTES :-**  
 1. THESE DRAWINGS ARE ONLY FOR UNDERSTANDING THE SCOPE OF THE WORK. IT IS NOT THE FINAL DOCUMENTATION FOR CONSTRUCTION ACTIVITIES.  
 2. ALL SUPPORTING MEMBERS REQUIRED FOR CABLE TRAYS, RACEWAYS, ETC ARE INCLUDED IN SQM RATE MENTIONED IN PEB BOQ. NO EXTRA PAYMENT WILL BE MADE FOR ANY SUPPORT MEMBER.

**GENERAL NOTES :-**  
 1. ALL DIMENSIONS ARE IN MILLIMETERS & LEVELS ARE IN METERS UNLESS MENTIONED OTHERWISE  
 2. ALL DIMENSIONS ARE TO BE READ AND NOT TO BE MEASURED  
 3. THIS DRAWING MUST BE READ IN CONJUNCTION WITH ALL RELEVANT ARCHITECTURAL, STRUCTURAL, PLUMBING, FIRE FIGHTING, ELECTRICAL AND TRAFFIC MANAGEMENT DRAWINGS  
 4. ANY DISCREPANCIES MUST BE BROUGHT UP TO THE NOTICE OF THE CONSULTANT.

**NOTES :-**  
 1. STRUCTURAL ARRANGEMENT PRESENTED ON THE DRAWING IS INDICATIVE, REFER STRUCTURAL DRAWINGS FOR THE SAME.  
 2. ROOF PROFILES AND HEIGHTS SHOWN ON THE DRAWINGS ARE INDICATIVE, SAME SHALL BE DETAILED AT LATER STAGE.  
 3. MEP REQUIREMENTS THUS INDICATED ON LAYOUTS SHALL BE DETAILED AT LATER STAGE.  
 4. LOCATIONS OF FHO, FIRE EXTINGUISHERS AND CUTOUPS WILL BE UPDATED AT LATER STAGES.  
 5. THE DRAWINGS HAVE BEEN DEVELOPED WITH RESPECT TO DPR AND LMRC REQUIREMENTS.  
 6. THE RAIL LEVELS INDICATED ON DRAWINGS ARE SUBJECT TO APPROVAL BY RELEVANT DISCIPLINES/LMRC. +128.6 (+0.00) HAS BEEN TAKEN AS RAIL LEVEL IN THE DRAWINGS.  
 7. ROAD LAYOUT FOR TRAIN MOVEMENT/ CAR PARKING SHOWN ON THE LAYOUT ARE TENTATIVE, SUBJECT TO APPROVAL BY RELEVANT DISCIPLINES/LMRC.  
 8. TRACK C/C DIMENSIONS PROVIDED RELATED TO THIRD RAIL SYSTEM REQUIREMENTS. REFER MOM 0-SYST-KNPDD-01-MOM-00010, DATED - 07.08.2019  
 9. NO. OF TOILETS AND FIXTURES SHOWN ON THE DRAWINGS ARE INDICATIVE. SHALL BE DETAILED AT A LATER STAGE.  
 10. THE BRACKET SIZES AND LEVELS FOR OVERHEAD CRANES SHALL BE AS VENDOR DETAILS AND DRAWINGS.  
 11. LIFT PIT DEPTH/WELL SIZES SHALL BE FIXED AS VENDOR DETAIL AND DRAWINGS.  
 12. ROOM SIZES, HEIGHTS AND DOOR OPENINGS SHALL BE CONFIRMED BY RELEVANT DISCIPLINES OF ENGINEERING.  
 13. SITE LEVELS SHALL BE UPDATED WITH RESPECT TO SURVEY DRAWINGS AT A LATER STAGE.  
 14. WINDOW/ GLAZING OPENING SIZES ARE INDICATIVE, SHALL BE DETAILED AT A LATER STAGE.  
 15. SIZES OF ALL MEP/ SYSTEMS/ TRACKS/ OTHER DISCIPLINES, MUST BE VERIFIED BY RELEVANT DISCIPLINES.  
 16. ALL MATERIALS/ FINISHES THUS MENTIONED ON THE DRAWINGS ARE SUBJECT TO LMRC REVIEW AND APPROVAL.  
 17. ALL PEB PROFILES/ STRUCTURAL SUPPORT SYSTEM SHOWN ON THE DRAWINGS ARE INDICATIVE ONLY. DETAIL TO BE PROVIDED BY THE PEB CONSULTANT.

**SCHEDULE OF OPENINGS**

NOTE: ALL SILL AND LIFT LEVELS ARE TO BE TAKEN FROM FINISHED FLOOR OF RESPECTIVE ROOM

S.No	Type	Width	Sill Lvl	Lift Lvl	Remarks
1	D1	1500	0.00	2100	AS PER SPEC.
2	D2	1200	0.00	2100	AS PER SPEC.
3	D3	1000	0.00	2100	AS PER SPEC.
4	D4	600	300	2100	AS PER SPEC.
5	SD	11700	0.00	2100	AS PER SPEC.
6	DF1	1200	0.00	2100	AS PER SPEC.
7	RS1	3000	0.00	3000	AS PER SPEC.
8	RS2	5000	0.00	5000	AS PER SPEC.

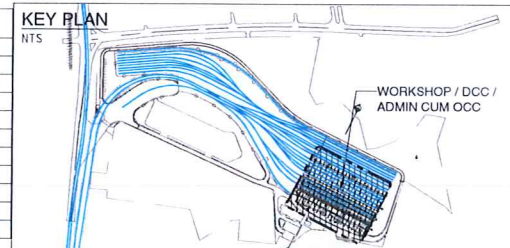

**NOTICE OF 'NO OBJECTIONS' FROM EMPLOYER**

NOTICE OF NO OBJECTION FROM EMPLOYER IS BEING ACCORDED FOR DESIGN PRINCIPLES HOWEVER THE OVERALL RESPONSIBILITY FOR THE DESIGN ACCURACY LIES WITH THE DETAIL DESIGN CONSULTANT.

REMARKS	DATE	SIGNATURE
DY CA - LMRC REVIEWED & NO OBJECTION MAY BE CONVEYED TO THE CONTRACTOR		
DY CE - LMRC BASED ON STAMPED ABOVE THE NO OBJECTION IS ISSUED FOR EXECUTION PURPOSE		
CPM - LMRC		

PROJECT TITLE  
**LUCKNOW METRO RAIL CORPORATION LTD.**  
 KNPDD01-IIT KANPUR-NAUBASTA CORRIDOR-1  
 (IMPLEMENTED BY LMRC)

REV.	PARTICULARS	DRN.	CHD.	VER.	DATE
R0	First Issue	PALUMAR	N.CHATURVEDI	ASHISH	19-09-19

DETAIL DESIGN CONSULTANT  
**SYSTRA**  
 SYSTRA MVA CONSULTING (INDIA) PVT. LTD.  
 VATIKA MINDSCAPES, TOWER-B, 12/3,  
 MATHURA ROAD, NH-2, SECTOR-27/D,  
 FARIDABAD, HARYANA-121013  
 PH: 0129 668 5600  
 SUBSIDIARY OF:  
 SYSTRA S.A. - 5 AVENUE DU COQ - PARIS 75009

IMPLEMENTED BY LMRC

NO OBJECTION FROM LMRC

PREPARED	NAME	SIGNATURE
DRAWN BY	P.KUMAR	
DESIGNED BY	N.MALIK	
CHECKED BY	N.CHATURVEDI	
APPROVED BY	ASHISH	

DRAWING TITLE	SCALE	DATE OF ISSUE	STAGE
POLYTECHNIC DEPOT-1 ADMINISTRATIVE BUILDING SECOND LEVEL PLAN	1:250	19-09-19	TENDER DRAWING

DRG NO. KNPDD01-TDR-DP1-ARC-PLN-91203

REV R0







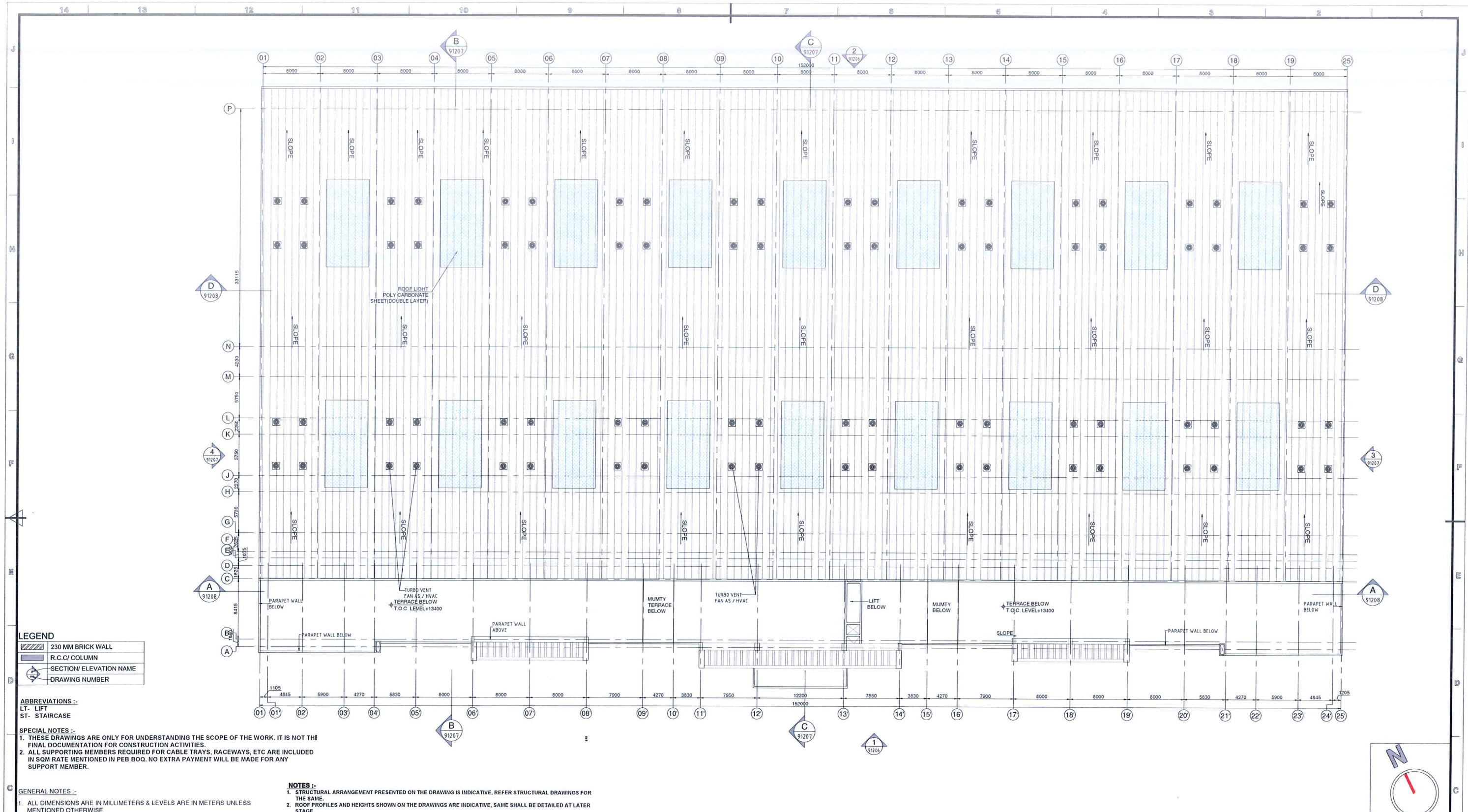

**LEGEND**

	230 MM BRICK WALL
	R.C.C/ COLUMN
	SECTION/ ELEVATION NAME
	DRAWING NUMBER

**ABBREVIATIONS :-**  
 LT- LIFT  
 ST- STAIRCASE

**SPECIAL NOTES :-**  
 1. THESE DRAWINGS ARE ONLY FOR UNDERSTANDING THE SCOPE OF THE WORK. IT IS NOT THE FINAL DOCUMENTATION FOR CONSTRUCTION ACTIVITIES.  
 2. ALL SUPPORTING MEMBERS REQUIRED FOR CABLE TRAYS, RACEWAYS, ETC ARE INCLUDED IN SQM RATE MENTIONED IN PEB BOQ. NO EXTRA PAYMENT WILL BE MADE FOR ANY SUPPORT MEMBER.

**GENERAL NOTES :-**  
 1. ALL DIMENSIONS ARE IN MILLIMETERS & LEVELS ARE IN METERS UNLESS MENTIONED OTHERWISE  
 2. ALL DIMENSIONS ARE TO BE READ AND NOT TO BE MEASURED  
 3. THIS DRAWING MUST BE READ IN CONJUNCTION WITH ALL RELEVANT ARCHITECTURAL, STRUCTURAL, PLUMBING, FIRE FIGHTING, ELECTRICAL AND TRAFFIC MANAGEMENT DRAWINGS.  
 4. ANY DISCREPANCIES MUST BE BROUGHT UP TO THE NOTICE OF THE CONSULTANT.

**NOTES :-**  
 1. STRUCTURAL ARRANGEMENT PRESENTED ON THE DRAWING IS INDICATIVE, REFER STRUCTURAL DRAWINGS FOR THE SAME.  
 2. ROOF PROFILES AND HEIGHTS SHOWN ON THE DRAWINGS ARE INDICATIVE, SAME SHALL BE DETAILED AT LATER STAGE.  
 3. MEP REQUIREMENTS THUS INDICATED ON LAYOUTS SHALL BE DETAILED AT LATER STAGE.  
 4. LOCATIONS OF FHC, FIRE EXTINGUISHERS AND CUTOUTS WILL BE UPDATED AT LATER STAGES.  
 5. THE DRAWINGS HAVE BEEN DEVELOPED WITH RESPECT TO DPR AND LMRC REQUIREMENTS.  
 6. THE RAIL LEVELS INDICATED ON DRAWINGS ARE SUBJECT TO APPROVAL BY RELEVANT DISCIPLINES/LMRC.  
 7. ROAD LAYOUT/PEDESTRIAN MOVEMENT/CAR PARKING SHOWN ON THE LAYOUT ARE TENTATIVE, SUBJECT TO APPROVAL BY RELEVANT DISCIPLINES/LMRC.  
 8. TRACK C/C DIMENSIONS PROVIDED RELATED TO THIRD RAIL SYSTEM REQUIREMENTS. REFER MOM 0-SYST-KNPDD-01-MOM-00010, DATED - 07.08.2019  
 9. NO. OF TOILETS AND FIXTURES SHOWN ON THE DRAWINGS ARE INDICATIVE. SHALL BE DETAILED AT A LATER STAGE.  
 10. THE BRACKET SIZES AND LEVELS FOR OVERHEAD CRANES SHALL BE AS/VENDOR DETAILS AND DRAWINGS.  
 11. LIFT PIT DEPTH/WELL SIZES SHALL BE FIXED AS/VENDOR DETAIL AND DRAWINGS.  
 12. ROOM SIZES, HEIGHTS AND DOOR OPENINGS SHALL BE CONFIRMED BY RELEVANT DISCIPLINES OF ENGINEERING.  
 13. SITE LEVELS SHALL BE UPDATED WITH RESPECT TO SURVEY DRAWINGS AT A LATER STAGE.  
 14. WINDOW/GLAZING OPENING SIZES ARE INDICATIVE, SHALL BE DETAILED AT A LATER STAGE.  
 15. SIZES OF ALL MEP/ SYSTEMS/TRACKS/OTHER DISCIPLINES, MUST BE VERIFIED BY RELEVANT DISCIPLINES.  
 16. ALL MATERIALS/ FINISHES THUS MENTIONED ON THE DRAWINGS ARE SUBJECT TO LMRC REVIEW AND APPROVAL.  
 17. ALL PEB PROFILES/STRUCTURAL SUPPORT SYSTEM SHOWN ON THE DRAWINGS ARE INDICATIVE ONLY. DETAIL TO BE PROVIDED BY THE PEB CONSULTANT.

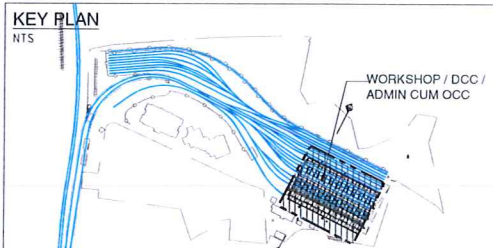

NOTICE OF 'NO OBJECTIONS' FROM EMPLOYER			
NOTICE OF NO OBJECTION FROM EMPLOYER IS BEING ACCORDED FOR DESIGN PRINCIPLES HOWEVER THE OVERALL RESPONSIBILITY FOR THE DESIGN ACCURACY LIES WITH THE DETAIL DESIGN CONSULTANT .			
	REMARKS	DATE	SIGNATURE
DY CA - LMRC	REVIEWED & NO OBJECTION MAY BE CONVEYED TO THE CONTRACTOR		
DY CE - LMRC	BASED ON STAMPED ABOVE THE NO OBJECTION IS ISSUED FOR EXECUTION PURPOSE		
CPM - LMRC			
PROJECT TITLE LUCKNOW METRO RAIL CORPORATION LTD. KNPDD01-IIT KANPUR-NAUBASTA CORRIDOR-1			
(IMPLEMENTED BY LMRC)			
NO OBJECTION FROM LMRC		PREPARED	NAME
		DRAWN BY	SIGNATURE
		DESIGNED BY	
		CHECKED BY	
		APPROVED BY	
DETAIL DESIGN CONSULTANT <b>SYSTRA</b> SYSTRA MVA CONSULTING (INDIA) PVT. LTD. VATIKA MINDSCAPES, TOWER-B, 12/3, MATHURA ROAD, NH-2, SECTOR-27/D, FARIDABAD, HARYANA-121013 PH: 0129 668 5600 SUBSIDIARY OF: SYSTRA S.A. - 5 AVENUE DU COQ - PARIS 75009		DRAWING TITLE POLYTECHNIC DEPOT-1 ADMINISTRATIVE BUILDING UPPER ROOF LEVEL PLAN	
REV. 00		SCALE 1:250	DATE OF ISSUE 19-09-19
PARTICULARS		DRG NO KNPDD01-TDR-DP1-ARC-PLN-91205	STAGE TENDER DRAWING
ORL.	CHD.	VER.	DATE
REV.			REV. R0

REV.	ORL.	CHD.	VER.	DATE



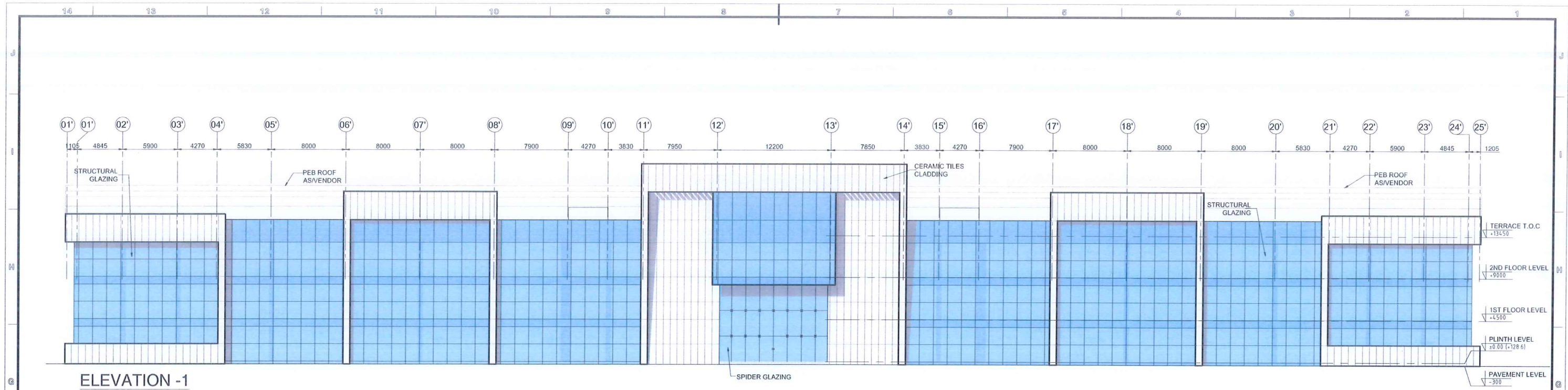

ELEVATION -1

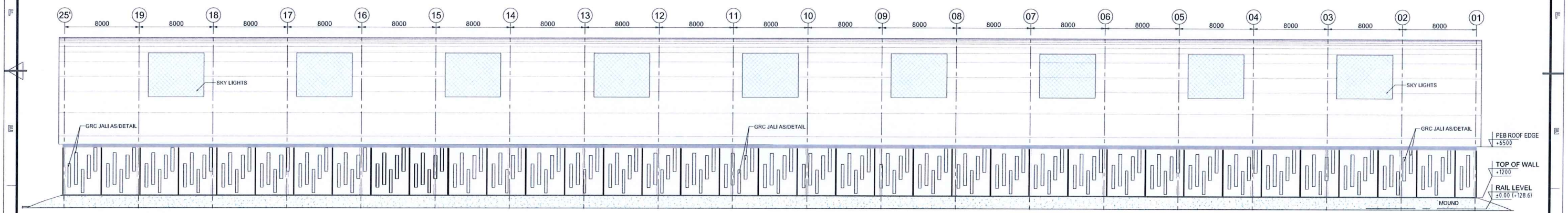

ELEVATION- 2

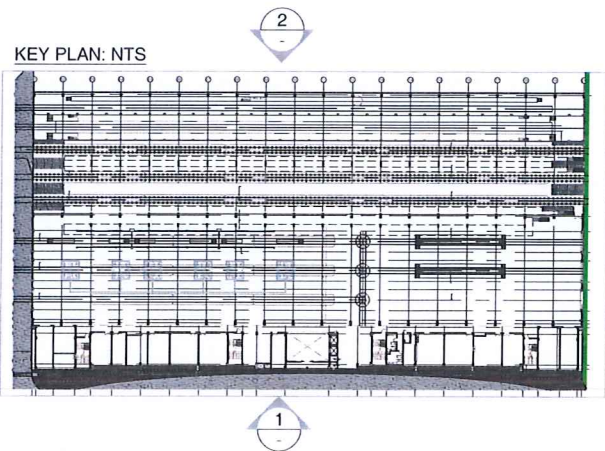

SPECIAL NOTES :-  
 1. THESE DRAWINGS ARE ONLY FOR UNDERSTANDING THE SCOPE OF THE WORK. IT IS NOT THE FINAL DOCUMENTATION FOR CONSTRUCTION ACTIVITIES.  
 2. ALL SUPPORTING MEMBERS REQUIRED FOR CABLE TRAYS, RACEWAYS, ETC ARE INCLUDED IN SQM RATE MENTIONED IN PEB BOQ. NO EXTRA PAYMENT WILL BE MADE FOR ANY SUPPORT MEMBER.

REV.	PARTICULARS	DRN.	CHD.	VER.	DATE
R3	Final Issue	P.KUMAR	N.CHATURVEDI	ASHISH	19-09-19

**LEGEND**

	TRACK ☐
	230 MM BRICK WALL
	R.C.C/ COLUMN
	SECTION/ ELEVATION NAME
	DRAWING NUMBER



DETAIL DESIGN CONSULTANT  
**SYSTRA**  
 SYSTRA MVA CONSULTING (INDIA) PVT. LTD.  
 VATIKA MINDSCAPES, TOWER-B, 12/3,  
 MATHURA ROAD, NH-2, SECTOR-27/D,  
 FARIDABAD, HARYANA-121013  
 PH: 0129 668 5600  
 SUBSIDIARY OF:  
 SYSTRA S.A. - 5 AVENUE DU COQ - PARIS 75009

NO OBJECTION FROM LMRC	PREPARED	NAME	SIGNATURE
	DRAWN BY	P.KUMAR	
	DESIGNED BY	N.A.MALKI	
	CHECKED BY	N.CHATURVEDI	
	APPROVED BY	ASHISH	

NOTICE OF 'NO OBJECTIONS' FROM EMPLOYER

NOTICE OF NO OBJECTION FROM EMPLOYER IS BEING ACCORDED FOR DESIGN PRINCIPLES HOWEVER THE OVERALL RESPONSIBILITY FOR THE DESIGN ACCURACY LIES WITH THE DETAIL DESIGN CONSULTANT .

REMARKS	DATE	SIGNATURE
DY CA - LMRC REVIEWED & NO OBJECTION MAY BE CONVEYED TO THE CONTRACTOR		
DY CE - LMRC BASED ON STAMPED ABOVE THE NO OBJECTION IS ISSUED FOR EXECUTION PURPOSE		
CPM - LMRC		

PROJECT TITLE  
**LUCKNOW METRO RAIL CORPORATION LTD.**  
 KNPDD01-IIT KANPUR-NAUBASTA CORRIDOR-1 (IMPLEMENTED BY LMRC)

DRAWING TITLE  
**POLYTECHNIC DEPOT-1**  
**ADMINISTRATIVE BUILDING**  
**ELEVATIONS- 1 & 2**

SCALE: 1:250  
 DATE OF ISSUE: 19-09-19  
 STAGE: TENDER DRAWING

DRG NO: KNPDD01-TDR-DP1-ARC-DET-91206  
 REV: R0



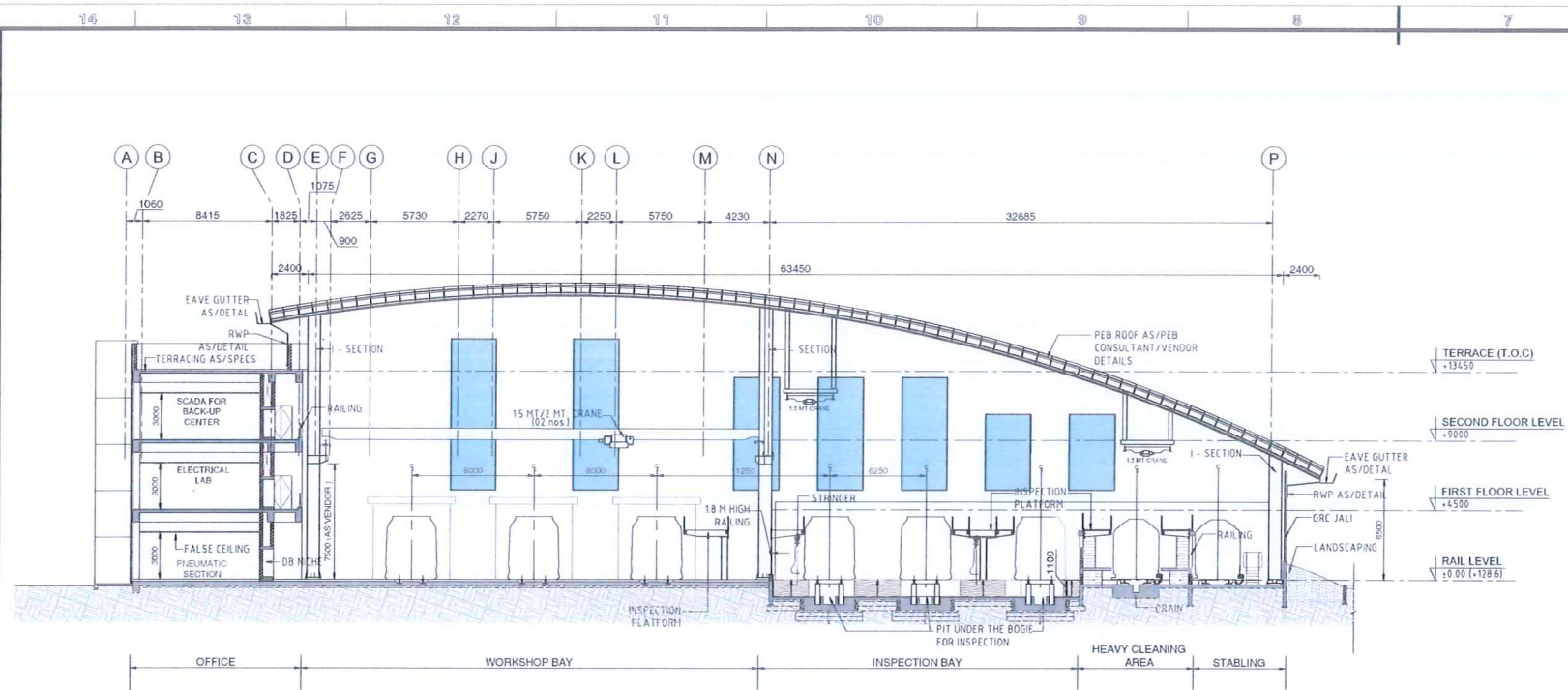

CROSS SECTION AT B  
SCALE: 1/200

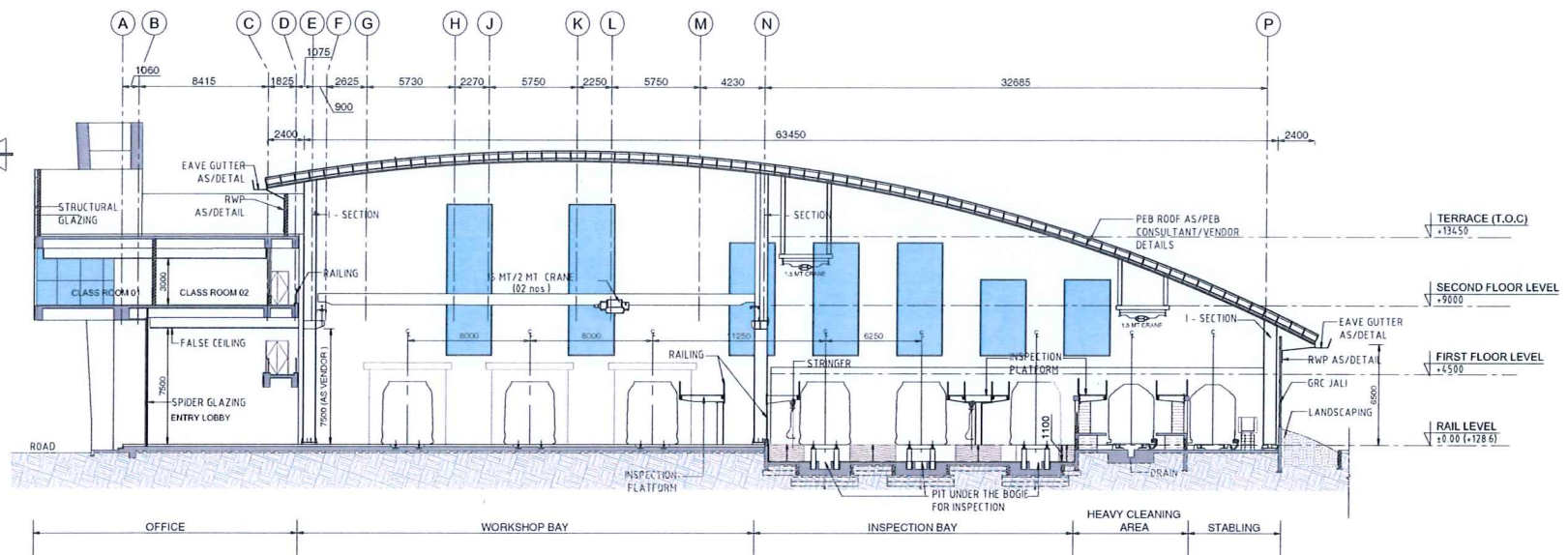

CROSS SECTION AT C  
SCALE: 1/200

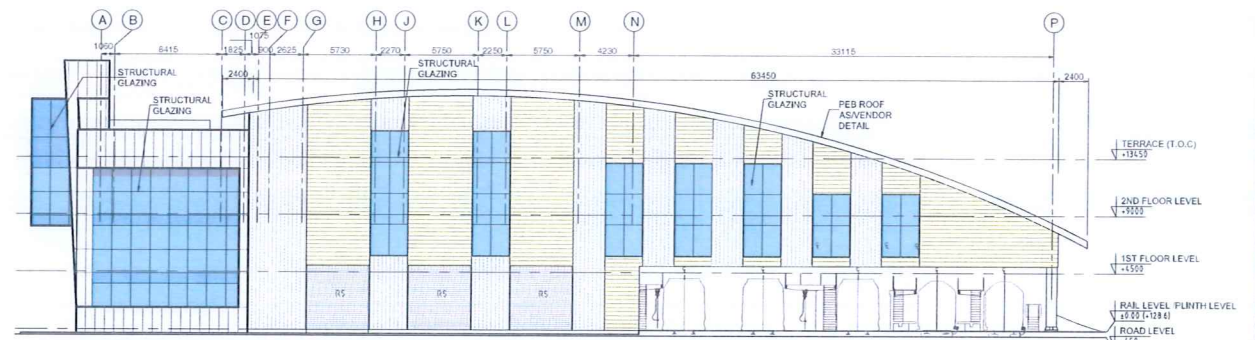

ELEVATION - 3

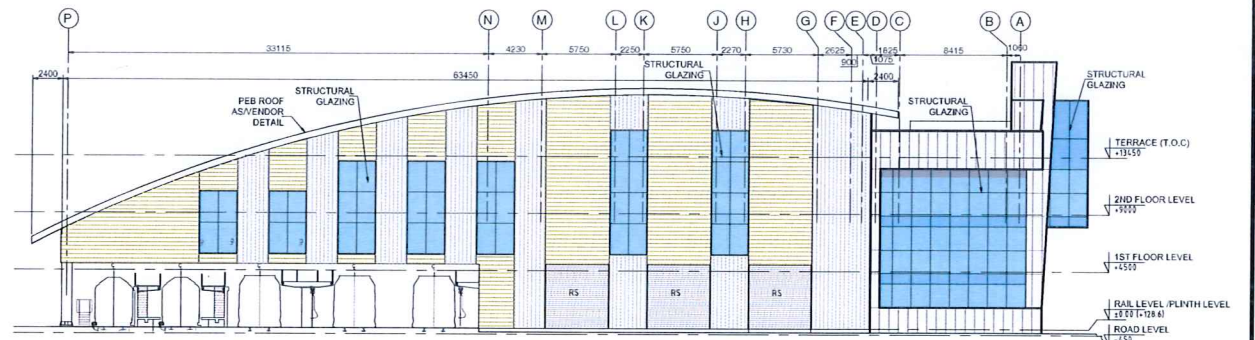

ELEVATION - 4

- SPECIAL NOTES :-**
- THESE DRAWINGS ARE ONLY FOR UNDERSTANDING OF SCOPE OF THE WORK. IT IS NOT THE FINAL DOCUMENTATION FOR CONSTRUCTION ACTIVITIES.
  - ALL SUPPORTING STRUCTURES REQUIRED FOR CABLE TRAYS, RACEWAYS, BRACKETS ARE SCOPE OF THIS TENDER.
  - THE SQUARE METER RATE MENTIONED IN BOQ IS INCLUSIVE OF ALL SUPPORTING BRACKETS, HANGERS REQUIRED FOR CABLE TRAYS, RACEWAYS ETC. NO EXTRA PAYMENT WILL BE MADE.
- NOTES :-**
- STRUCTURAL ARRANGEMENT PRESENTED ON THE DRAWING IS INDICATIVE. REFER STRUCTURAL DRAWINGS FOR THE SAME.
  - ROOF PROFILES AND HEIGHTS SHOWN ON THE DRAWINGS ARE INDICATIVE. SAME SHALL BE DETAILED AT LATER STAGE.
  - MEP REQUIREMENTS THUS INDICATED ON LAYOUTS SHALL BE DETAILED AT LATER STAGE.
  - LOCATIONS OF FNC, FIRE EXTINGUISHERS AND CUTOUPS WILL BE UPDATED AT LATER STAGES.
  - THE DRAWINGS HAVE BEEN DEVELOPED WITH RESPECT TO DPR AND LMRC REQUIREMENTS.
  - THE RAIL LEVELS INDICATED ON DRAWINGS ARE SUBJECT TO APPROVAL BY RELEVANT DISCIPLINES/LMRC. +128.6 (+0.00) HAS BEEN TAKEN AS RAIL LEVEL IN THE DRAWINGS.
  - ROAD LAYOUT/PEDESTRIAN MOVEMENT/CAR PARKING SHOWN ON THE LAYOUT ARE TENTATIVE, SUBJECT TO APPROVAL BY RELEVANT DISCIPLINE/LMRC.
  - TRACK C/C DIMENSIONS PROVIDED RELATED TO THIRD RAIL SYSTEM REQUIREMENTS. REFER MOM 0-SYST-KIPDD-01-4010-00010, DATED - 07.08.2019.
  - NO. OF TOILETS AND FIXTURES SHOWN ON THE DRAWINGS ARE INDICATIVE. SHALL BE DETAILED AT A LATER STAGE.
  - THE BRACKET SIZES AND LEVELS FOR OVERHEAD CRANES SHALL BE AS/VENDOR DETAILS AND DRAWINGS.
  - LIFT PIT DEPTH/WELL SIZES SHALL BE FIXED AS/VENDOR DETAIL AND DRAWINGS.
  - ROOM SIZES/HEIGHTS AND DOOR OPENINGS SHALL BE CONFIRMED BY RELEVANT DISCIPLINES OF ENGINEERING.
  - SITE LEVELS SHALL BE UPDATED WITH RESPECT TO SURVEY DRAWINGS AT A LATER STAGE.
  - WINDOW/GLAZING OPENING SIZES ARE INDICATIVE. SHALL BE DETAILED AT A LATER STAGE.
  - SIZES OF ALL MEP SYSTEMS/TRACKS/OTHER DISCIPLINES, MUST BE VERIFIED BY RELEVANT DISCIPLINES.
  - ALL MATERIALS/ FINISHES THUS MENTIONED ON THE DRAWINGS ARE SUBJECT TO LMRC REVIEW AND APPROVAL.
  - ALL PEB PROFILES/STRUCTURAL SUPPORT SYSTEM SHOWN ON THE DRAWINGS ARE INDICATIVE ONLY. DETAIL TO BE PROVIDED BY THE PEB CONSULTANT.

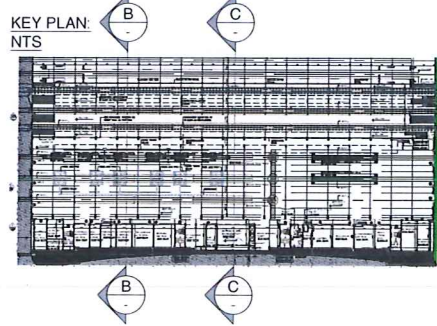

- SPECIAL NOTES :-**
- THESE DRAWINGS ARE ONLY FOR UNDERSTANDING THE SCOPE OF THE WORK. IT IS NOT THE FINAL DOCUMENTATION FOR CONSTRUCTION ACTIVITIES.
  - ALL SUPPORTING MEMBERS REQUIRED FOR CABLE TRAYS, RACEWAYS, ETC ARE INCLUDED IN SQM RATE MENTIONED IN PEB BOQ. NO EXTRA PAYMENT WILL BE MADE FOR ANY SUPPORT MEMBER.

**LEGEND**

	TRACK C
	230 MM BRICK WALL
	R.C.C./ COLUMN
	SECTION/ ELEVATION NAME
	DRAWING NUMBER



IMPLEMENTED BY LMRC



DETAIL DESIGN CONSULTANT  
**SYSTRA MVA CONSULTING (INDIA) PVT. LTD.**  
 VATIKA MINDSCAPES, TOWER-B, 12/3,  
 MATHURA ROAD, NH-2, SECTOR-27/D,  
 FARIDABAD, HARYANA-121013  
 PH: 0129 668 5600  
 SUBSIDIARY OF:  
 SYSTRA S.A. - 5 AVENUE DU COQ - PARIS 75009

NO OBJECTION FROM LMRC	PREPARED	NAME	SIGNATURE
	DRAWN BY	PXUMAR	
	DESIGNED BY	N.A.MALK	
	CHECKED BY	N.CHATURVEDI	
	APPROVED BY	ASHISH	

NOTICE OF NO OBJECTIONS FROM EMPLOYER			
NOTICE OF NO OBJECTION FROM EMPLOYER IS BEING ACCORDED FOR DESIGN PRINCIPLES HOWEVER THE OVERALL RESPONSIBILITY FOR THE DESIGN ACCURACY LIES WITH THE DETAIL DESIGN CONSULTANT.			
	REMARKS	DATE	SIGNATURE
DY CA - LMRC	REVIEWED & NO OBJECTION MAY BE CONVEYED TO THE CONTRACTOR		
DY CE - LMRC	BASED ON STAMPED ABOVE THE NO OBJECTION IS ISSUED FOR EXECUTION PURPOSE		
CPM - LMRC			
PROJECT TITLE <b>LUCKNOW METRO RAIL CORPORATION LTD.</b> KNPD01-IIT KANPUR-NAUBASTA CORRIDOR-1 (IMPLEMENTED BY LMRC)			
DRAWING TITLE <b>POLYTECHNIC DEPOT-1      ADMINISTRATIVE BUILDING      ELEVATIONS-3.4 &amp; SECTIONS-B,C</b>		SCALE 1:250	DATE OF ISSUE 19-09-19
STAGE TENDER DRAWING		DRG NO KNPD01-TDR-DP1-ARC-DET-91207	REV. A0



REV.	NO.	DATE	DRN.	CHD.	VER.	DATE
			PXUMAR	NCHATURVEDI	ASHISH	19-09-19



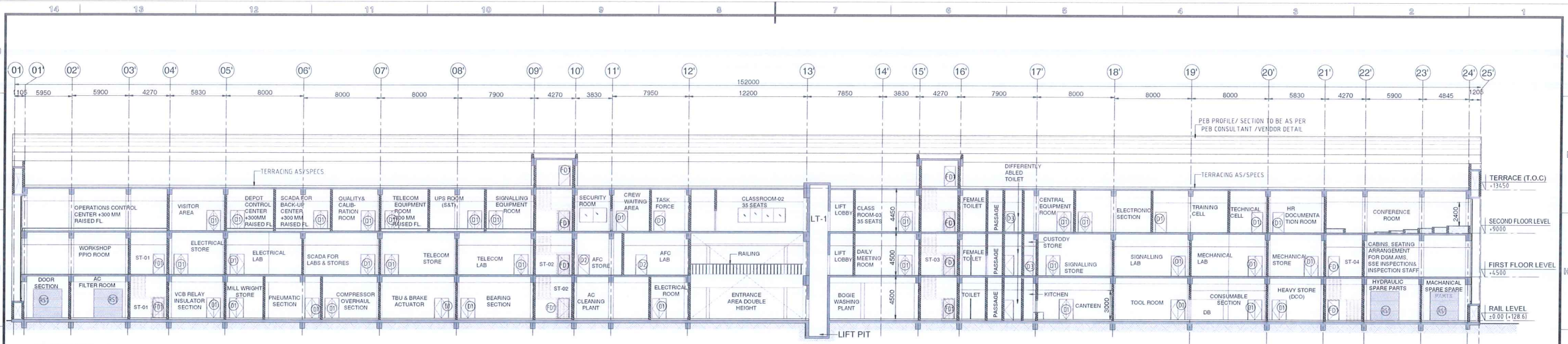

SECTION- A

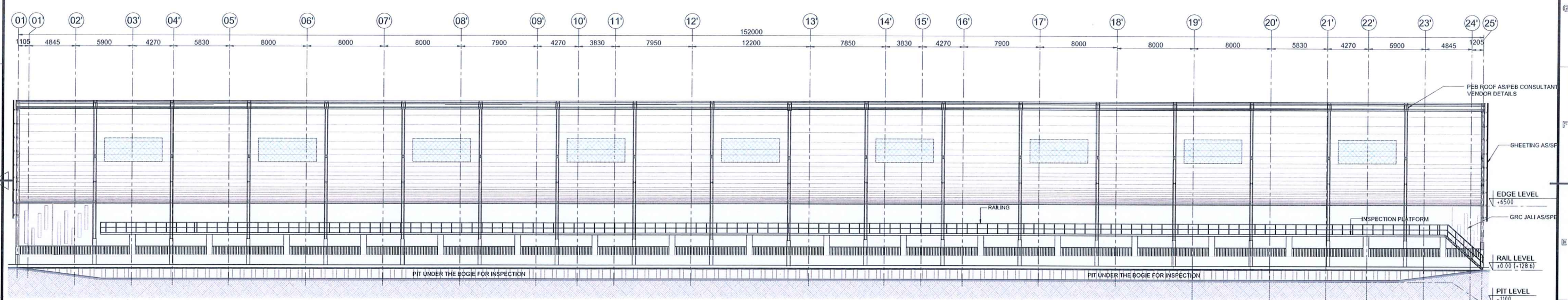

SECTION- D

**ABBREVIATIONS :-**  
 LT- LIFT  
 ST- STAIRCASE

**SPECIAL NOTES :-**  
 1. THESE DRAWINGS ARE ONLY FOR UNDERSTANDING OF SCOPE OF THE WORK. IT IS NOT THE FINAL DOCUMENTATION FOR CONSTRUCTION ACTIVITIES.  
 2. ALL SUPPORTING STRUCTURES REQUIRED FOR CABLE TRAYS, RACEWAYS, BRACKETS ARE SCOPE OF THIS TENDER.  
 3. THE SQUARE METER RATE MENTIONED IN BOQ IS INCLUSIVE OF ALL SUPPORTING BRACKETS, HANGERS REQUIRED FOR CABLE TRAYS, RACEWAYS ETC. NO EXTRA PAYMENT WILL BE MADE.

**NOTES :-**  
 1. STRUCTURAL ARRANGEMENT PRESENTED ON THE DRAWING IS INDICATIVE, REFER STRUCTURAL DRAWINGS FOR THE SAME.  
 2. ROOF PROFILES AND HEIGHTS SHOWN ON THE DRAWINGS ARE INDICATIVE, SAME SHALL BE DETAILED AT LATER STAGE.  
 3. MEP REQUIREMENTS THIS INDICATED ON LAYOUTS SHALL BE DETAILED AT LATER STAGE.  
 4. LOCATIONS OF FHC, FIRE EXTINGUISHERS AND CUTOUTS WILL BE UPDATED AT LATER STAGES.  
 5. THE DRAWINGS HAVE BEEN DEVELOPED WITH RESPECT TO DPR AND LMRC REQUIREMENTS.  
 6. THE RAIL LEVELS INDICATED ON DRAWINGS ARE SUBJECT TO APPROVAL BY RELEVANT DISCIPLINES/LMRC. +128.6 (+0.00) HAS BEEN TAKEN AS RAIL LEVEL IN THE DRAWINGS.  
 7. ROAD LAYOUT/PEDESTRIAN MOVEMENT/CAR PARKING SHOWN ON THE LAYOUT ARE TENTATIVE, SUBJECT TO APPROVAL BY RELEVANT DISCIPLINES/LMRC.  
 8. TRACK C/C DIMENSIONS PROVIDED RELATED TO THIRD RAIL SYSTEM REQUIREMENTS. REFER MOM 0-SYST-KNPD01-MOM-00010, DATED - 07.08.2019  
 9. NO. OF TOILETS AND FIXTURES SHOWN ON THE DRAWINGS ARE INDICATIVE. SHALL BE DETAILED AT A LATER STAGE.  
 10. THE BRACKET SIZES AND LEVELS FOR OVERHEAD CRANES SHALL BE AS/VENDOR DETAILS AND DRAWINGS.  
 11. LIFT PIT DEPTH/WELL SIZES SHALL BE FIXED AS/VENDOR DETAIL AND DRAWINGS.  
 12. ROOM SIZES, HEIGHTS AND DOOR OPENINGS SHALL BE CONFIRMED BY RELEVANT DISCIPLINES OF ENGINEERING.  
 13. SITE LEVELS SHALL BE UPDATED WITH RESPECT TO SURVEY DRAWINGS AT A LATER STAGE.  
 14. WINDOW/GLAZING OPENING SIZES ARE INDICATIVE. SHALL BE DETAILED AT A LATER STAGE.  
 15. SIZES OF ALL MEP/ SYSTEMS/TRACKS/OTHER DISCIPLINES, MUST BE VERIFIED BY RELEVANT DISCIPLINES.  
 16. ALL MATERIALS/ FINISHES THIS MENTIONED ON THE DRAWINGS ARE SUBJECT TO LMRC REVIEW AND APPROVAL.  
 17. ALL PEB PROFILES/ STRUCTURAL SUPPORT SYSTEM SHOWN ON THE DRAWINGS ARE INDICATIVE ONLY. DETAIL TO BE PROVIDED BY THE PEB CONSULTANT.

**GENERAL NOTES :-**  
 1. ALL DIMENSIONS ARE IN MILLIMETERS & LEVELS ARE IN METERS UNLESS MENTIONED OTHERWISE  
 2. ALL DIMENSIONS ARE TO BE READ AND NOT TO BE MEASURED  
 3. THIS DRAWING MUST BE READ IN CONJUNCTION WITH ALL RELEVANT ARCHITECTURAL, STRUCTURAL, PLUMBING, FIRE FIGHTING, ELECTRICAL AND TRAFFIC MANAGEMENT DRAWINGS  
 4. ANY DISCREPANCIES MUST BE BROUGHT UP TO THE NOTICE OF THE CONSULTANT.

REV.	NO.	DESCRIPTION	DATE

**LEGEND**

- TRACK C
- 230 MM BRICK WALL
- R.C.C/ COLUMN
- SECTION/ ELEVATION NAME
- DRAWING NUMBER

**SCHEDULE OF OPENINGS**

NOTE: ALL SILL AND LINTEL LEVELS ARE TO BE TAKEN FROM FINISHED FLOOR OF RESPECTIVE ROOM.

S.No	Type	Width	Sill Lvl	Lintel Lvl	Remarks
1	D1	1500	0.00	2100	AS PER SPEC.
2	D2	1200	0.00	2100	AS PER SPEC.
3	D3	1000	0.00	2100	AS PER SPEC.
4	D4	600	300	2100	AS PER SPEC.
5	SD	11700	0.00	2100	AS PER SPEC.
6	FD1	1200	0.00	2100	AS PER SPEC.
7	RS1	3000	0.00	3000	AS PER SPEC.
8	RS2	5000	0.00	5000	AS PER SPEC.

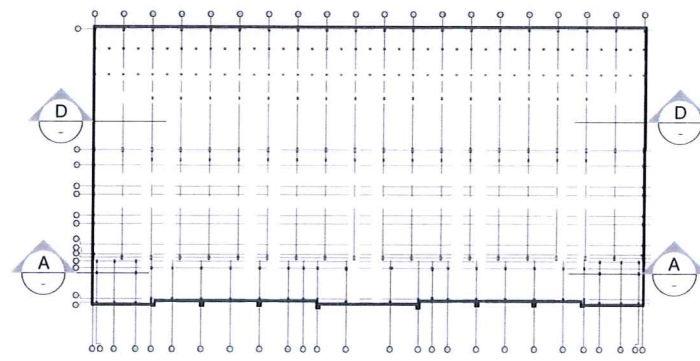

NOTICE OF 'NO OBJECTIONS' FROM EMPLOYER  
 NOTICE OF NO OBJECTION FROM EMPLOYER IS BEING ACCORDED FOR DESIGN PRINCIPLES HOWEVER THE OVERALL RESPONSIBILITY FOR THE DESIGN ACCURACY LIES WITH THE DETAIL DESIGN CONSULTANT.

REMARKS	DATE	SIGNATURE
DY CA - LMRC REVIEWED & NO OBJECTION MAY BE CONVEYED TO THE CONTRACTOR		
DY CE - LMRC BASED ON STAMPED ABOVE THE NO OBJECTION IS ISSUED FOR EXECUTION PURPOSE		
CPM - LMRC		

PROJECT TITLE  
**LUCKNOW METRO RAIL CORPORATION LTD.**  
 KNPDD01-IIT KANPUR-NAUBASTA CORRIDOR-1

(IMPLEMENTED BY LMRC)

ARCHITECTURE

NO OBJECTION FROM LMRC	PREPARED	NAME	SIGNATURE	DRAWING TITLE
				<b>POLYTECHNIC DEPOT-1</b>
				<b>ADMINISTRATIVE BUILDING</b>
				<b>SECTIONS- A &amp; D</b>

SCALE: 1:200      DATE OF ISSUE: 19-09-19      STAGE: TENDER DRAWING

DRG NO: KNPDD01-TR-DP1-ARC-DET-91208      REV: R0



DETAIL DESIGN CONSULTANT  
**SYSTRA**  
 SYSTRA MVA CONSULTING (INDIA) PVT. LTD.  
 VATIKA MINDSCAPES, TOWER-B, 12/3,  
 MATHURA ROAD, NH-2, SECTOR-27/D,  
 FARIDABAD, HARYANA-121013  
 PH: 0129 668 5600  
 SUBSIDIARY OF:  
 SYSTRA S.A. - 5 AVENUE DU COO - PARIS 75009

REV.	NO.	DESCRIPTION	DATE



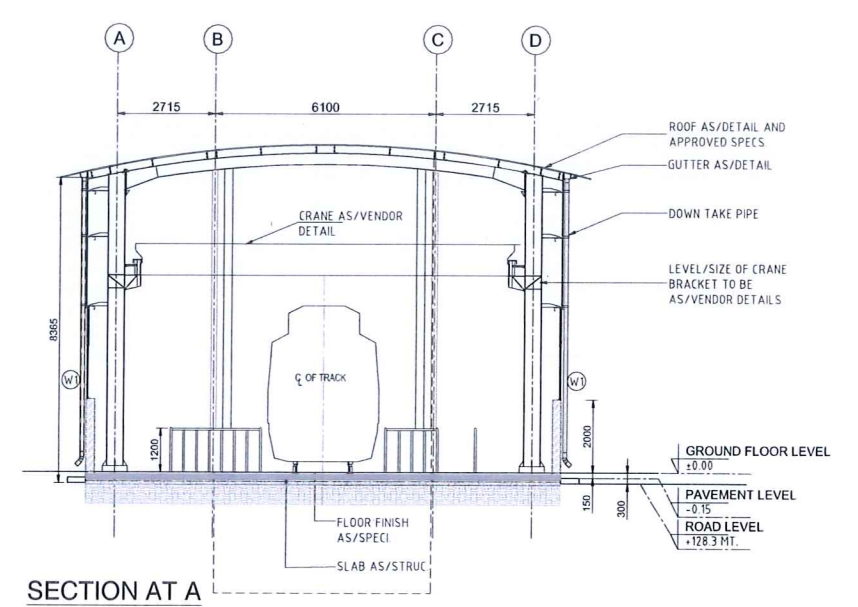
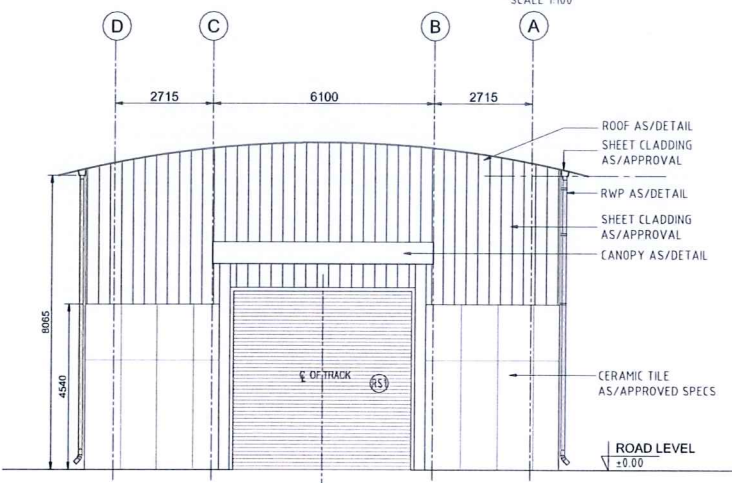
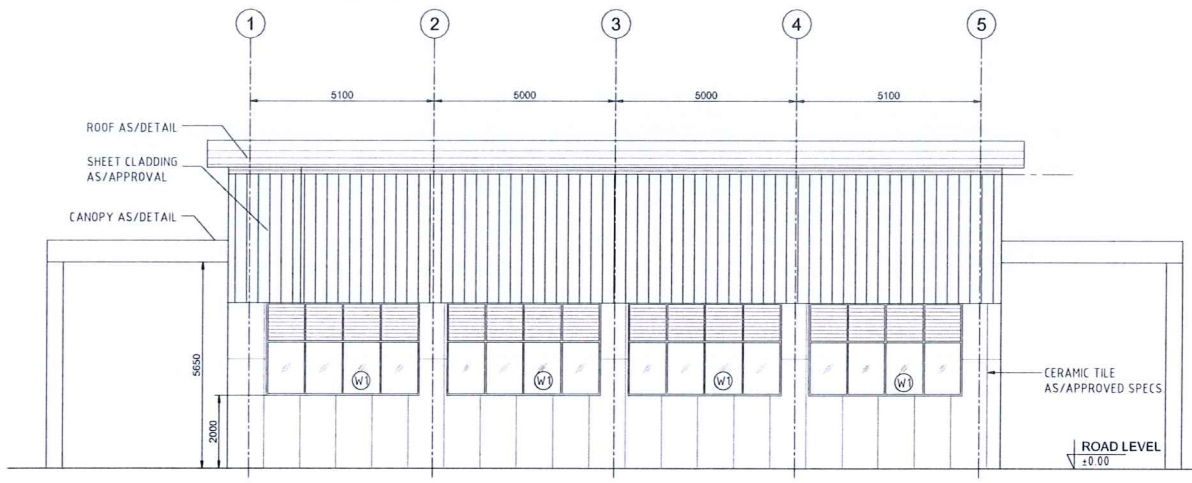
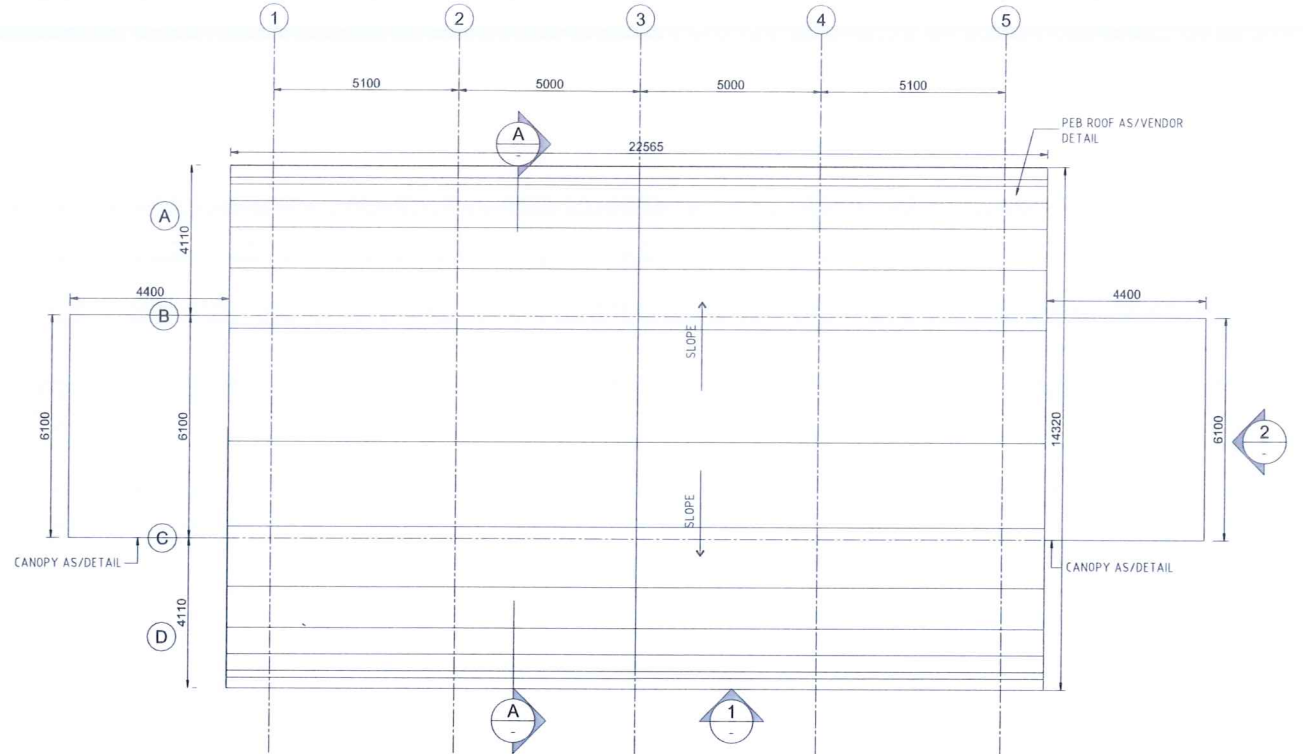
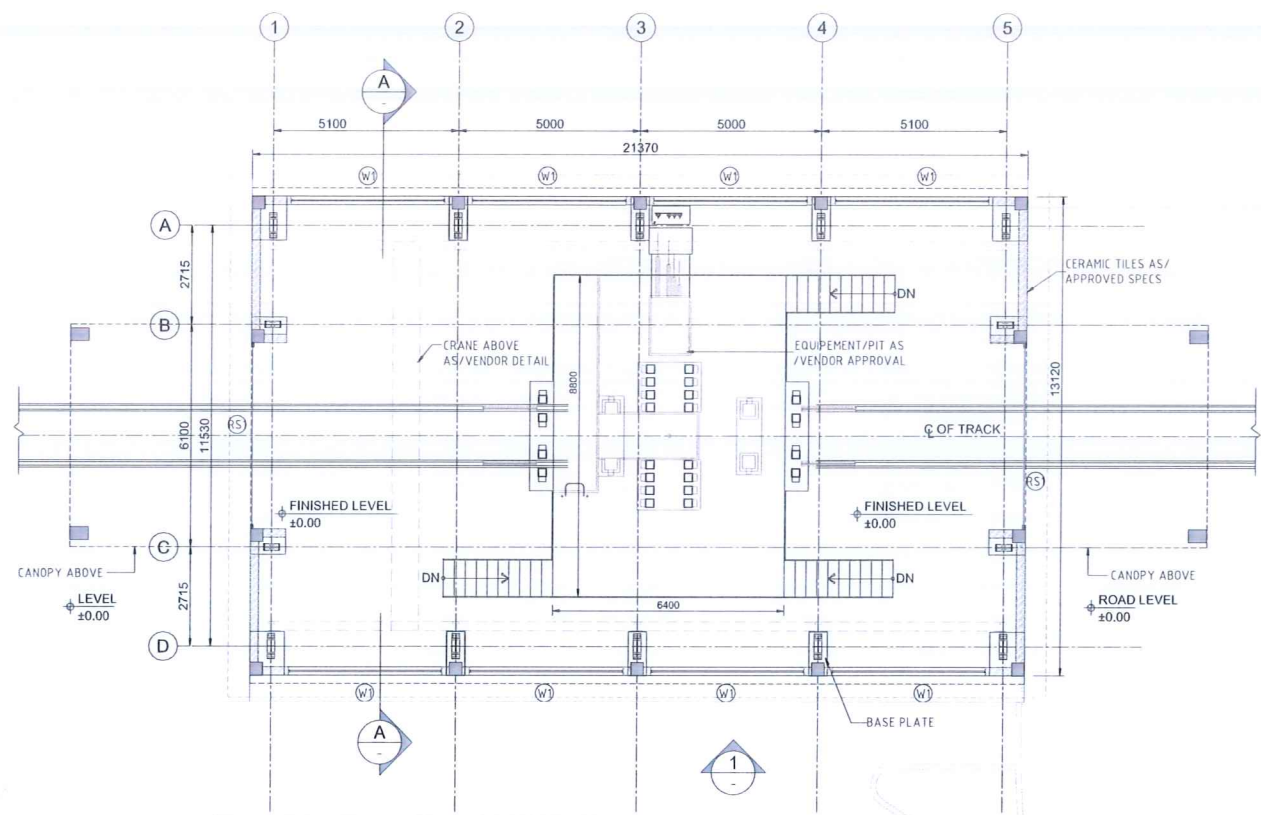

- GENERAL NOTES :-**
- ALL DIMENSIONS ARE IN MILLIMETERS & LEVELS ARE IN METERS UNLESS MENTIONED OTHERWISE
  - ALL DIMENSIONS ARE TO BE READ AND NOT TO BE MEASURED.
  - THIS DRAWING MUST BE READ IN CONJUNCTION WITH ALL RELEVANT ARCHITECTURAL, STRUCTURAL, PLUMBING, FIRE FIGHTING, ELECTRICAL AND TRAFFIC MANAGEMENT DRAWINGS
  - ANY DISCREPANCIES MUST BE BROUGHT UP TO THE NOTICE OF THE CONSULTANT.

- SPECIAL NOTES :-**
- THESE DRAWINGS ARE ONLY FOR UNDERSTANDING THE SCOPE OF THE WORK. IT IS NOT THE FINAL DOCUMENTATION FOR CONSTRUCTION ACTIVITIES.
  - ALL SUPPORTING MEMBERS REQUIRED FOR CABLE TRAYS, RACEWAYS, ETC ARE INCLUDED IN SOM RATE MENTIONED IN PEB BOQ. NO EXTRA PAYMENT WILL BE MADE FOR ANY SUPPORT MEMBER.

SCHEDULE OF OPENINGS				LEGEND	
NOTE: ALL SILL AND LINTEL LEVELS ARE TO BE TAKEN FROM FINISHED FLOOR OF RESPECTIVE ROOM					TRACK
					230 MM BRICK WALL
					R.C.C/ COLUMN
					SECTION/ ELEVATION NAME
					DRAWING NUMBER
S.No	Type	Width	Sill Lvl	Lintel Lvl	
1.	W1	4240	2300	4800	
2.	RS1	5100	0.00	5000	

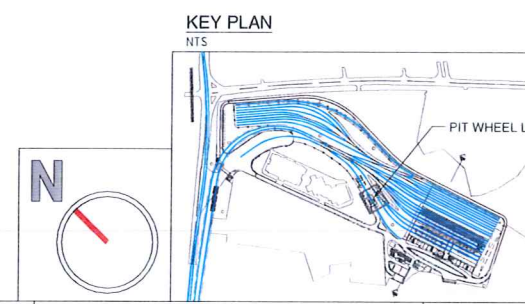

NOTICE OF 'NO OBJECTIONS' FROM EMPLOYER

NOTICE OF NO OBJECTION FROM EMPLOYER IS BEING ACCORDED FOR DESIGN PRINCIPLES HOWEVER THE OVERALL RESPONSIBILITY FOR THE DESIGN ACCURACY LIES WITH THE DETAIL DESIGN CONSULTANT.

REMARKS	DATE	SIGNATURE
DY CA - LMRC REVIEWED & NO OBJECTION MAY BE CONVEYED TO THE CONTRACTOR		
DY CE - LMRC BASED ON STAMPED ABOVE THE NO OBJECTION IS ISSUED FOR EXECUTION PURPOSE		
CPM - LMRC		

PROJECT TITLE  
**LUCKNOW METRO RAIL CORPORATION LTD.**  
KNPDD01-IIT KANPUR-NAUBASTA CORRIDOR-1

(IMPLEMENTED BY LMRC)

NO OBJECTION FROM LMRC	PREPARED	NAME	SIGNATURE	DRAWING TITLE
				POLYTECHNIC DEPOT-1
	DRAWN BY	P.KUMAR		PIT WHEEL LATHE
	DESIGNED BY	N.A.MALK		GROUND FLOOR PLAN, ROOF LEVEL PLAN, ELEVATIONS-1,2, SECTION-A
	CHECKED BY	N.CHATURVEDI		SCALE 1:100
	APPROVED BY	ASHISH		DATE OF ISSUE 19-09-19
				STAGE TENDER DRAWING
				DRG NO. KNPDD01-TDR-DP1-ARC-PLN-91301

REV.	PARTICULARS	DRN.	CHD.	VER.	DATE



DETAIL DESIGN CONSULTANT  
**SYSTRA**  
SYSTRA MVA CONSULTING (INDIA) PVT. LTD.  
VATIKA MINDSCAPES, TOWER-B, 12/3,  
MATHURA ROAD, NH-2, SECTOR-27/D,  
FARIDABAD, HARYANA-121013  
PH: 0129 668 5600  
SUBSIDIARY OF:  
SYSTRA S.A. - 5 AVENUE DU COQ - PARIS 75009

ARCHITECTURE



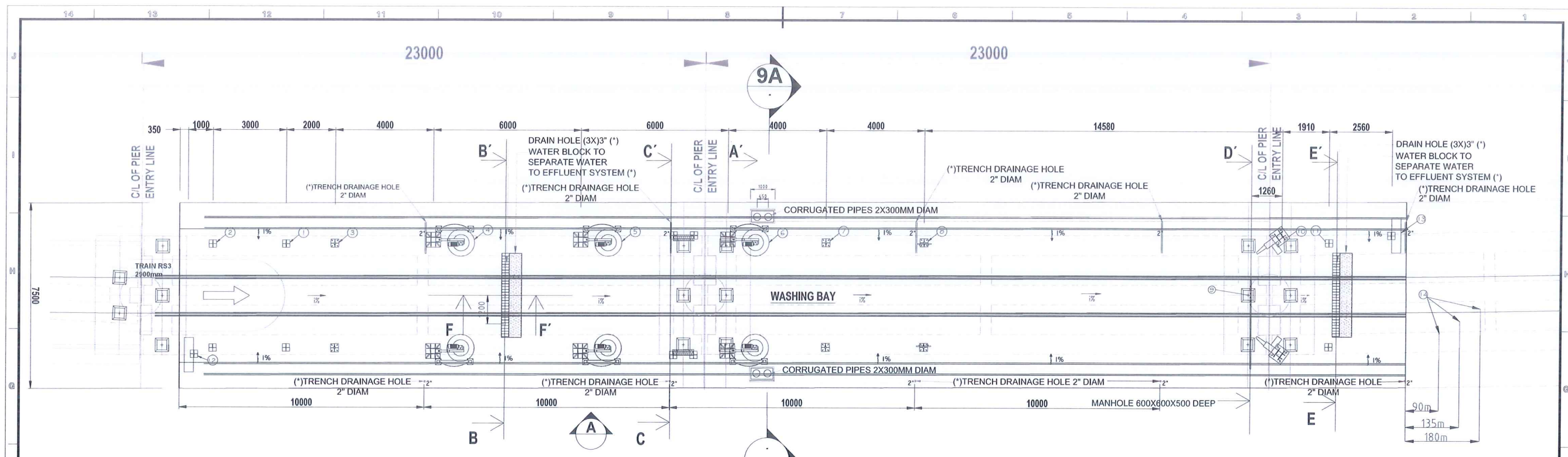

PLAN

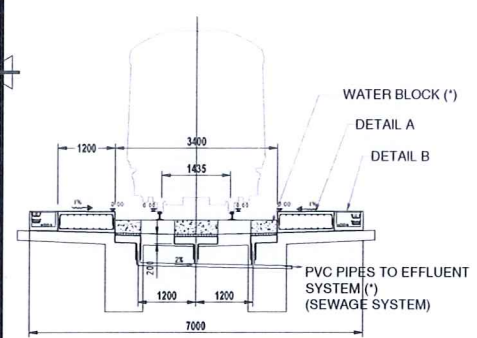

SECTION BB'

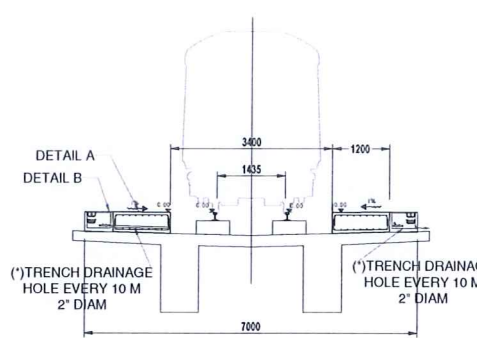

SECTION CC'

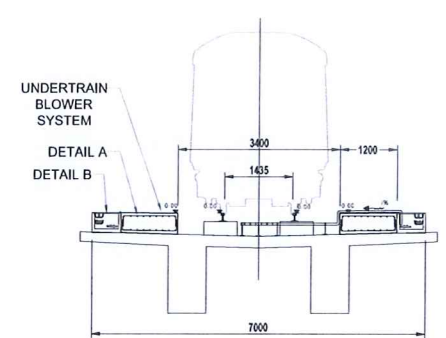

SECTION DD'

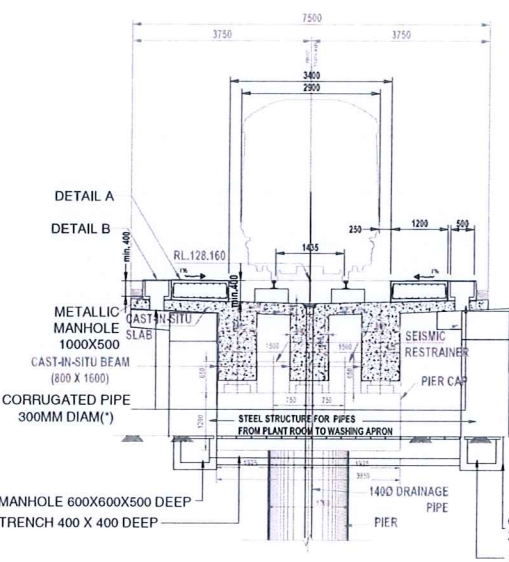

SECTION EE'

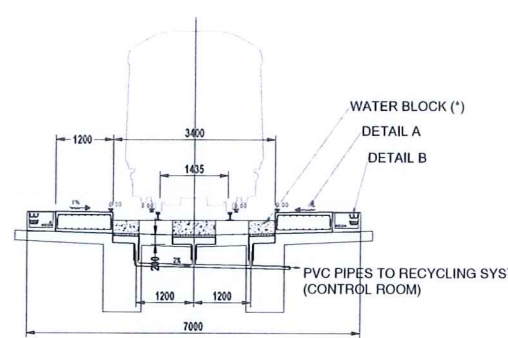

SECTION FF'

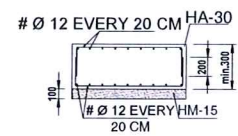

DETAIL A

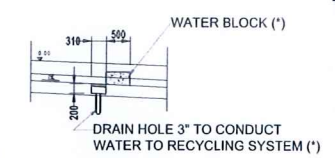

DETAIL B

- GENERAL NOTES :-**
- ALL DIMENSIONS ARE IN MILLIMETERS & LEVELS ARE IN METERS UNLESS MENTIONED OTHERWISE
  - ALL DIMENSIONS ARE TO BE READ AND NOT TO BE MEASURED
  - THIS DRAWING MUST BE READ IN CONJUNCTION WITH ALL RELEVANT ARCHITECTURAL, STRUCTURAL, PLUMBING, FIRE FIGHTING, ELECTRICAL AND TRAFFIC MANAGEMENT DRAWINGS
  - ANY DISCREPANCIES MUST BE BROUGHT UP TO THE NOTICE OF THE CONSULTANT

- SPECIAL NOTES :-**
- THESE DRAWINGS ARE ONLY FOR UNDERSTANDING THE SCOPE OF THE WORK. IT IS NOT THE FINAL DOCUMENTATION FOR CONSTRUCTION ACTIVITIES.
  - ALL SUPPORTING MEMBERS REQUIRED FOR CABLE TRAYS, RACEWAYS, ETC ARE INCLUDED IN SQM RATE MENTIONED IN PEB BOQ. NO EXTRA PAYMENT WILL BE MADE FOR ANY SUPPORT MEMBER.
- NOTES :-**
- SITE PLAN HAS BEEN PROPOSED BASED ON TRACK & BUILDING LAYOUT RECEIVED FROM LMRC THROUGH MAIL DATED 13.09.2019
  - MEP REQUIREMENTS THUS INDICATED ON LAYOUTS SHALL BE DETAILED AT LATER STAGE.
  - THE DRAWINGS HAVE BEEN DEVELOPED WITH RESPECT TO DPR AND LMRC REQUIREMENTS.
  - THE RAIL LEVELS INDICATED ON DRAWINGS ARE SUBJECT TO APPROVAL BY RELEVANT DISCIPLINES/LMRC. +128.6 (+0.00) HAS BEEN TAKEN AS RAIL LEVEL IN THE DRAWINGS.
  - TRACK C/C DIMENSIONS PROVIDED RELATED TO THIRD RAIL SYSTEM REQUIREMENTS. REFER MOM 0-SYST-KNPDD-01-MOM-00010, DATED - 07.08.2019. SUBJECT TO APPROVAL OF CONCERN DISCIPLINE/LMRC.
  - SITE LEVELS SHALL BE UPDATED WITH RESPECT TO SERVICES DESIGN AT LATER STAGE.
  - SIZES OF ALL MEP/ SYSTEMS/TRACKS/OTHER DISCIPLINES, MUST BE VERIFIED BY RELEVANT DISCIPLINES.
  - ALL MATERIALS/ FINISHES THUS MENTIONED ON THE DRAWINGS ARE SUBJECT TO LMRC REVIEW AND APPROVAL.
  - IT IS RECOMMENDED TO PROVIDE SAFETY FENCING AT PLACES WHERE THIRD RAIL TRACTION SYSTEM IS EASILY ACCESSIBLE BY PUBLIC, AS IT CAN BE A LIFE THREATENING HAZARD.
  - TRACK LENGTH FOR PIT WHEEL LATHE TO BE CONFIRMED BY CONCERN DISCIPLINE/ LMRC.

**PIPE LEGEND**

- RECYCLED WATER PIPE DN 50 mm
- RECYCLED WATER + DET. PIPE DN 32 mm
- DEMNERIALIZED WATER PIPE DN 50 mm
- OSMOTIC WATER PIPE DN 32 mm
- ELECTRICAL SUPPLY
- COMPRESSED AIR SUPPLY

NOTICE OF 'NO OBJECTIONS' FROM EMPLOYER

NOTICE OF NO OBJECTION FROM EMPLOYER IS BEING ACCORDED FOR DESIGN PRINCIPLES HOWEVER THE OVERALL RESPONSIBILITY FOR THE DESIGN ACCURACY LIES WITH THE DETAIL DESIGN CONSULTANT.

REMARKS	DATE	SIGNATURE
DY CA - LMRC REVIEWED & NO OBJECTION MAY BE CONVEYED TO THE CONTRACTOR		
DY CE - LMRC BASED ON STAMPED ABOVE THE NO OBJECTION IS ISSUED FOR EXECUTION PURPOSE		
CPM - LMRC		

PROJECT TITLE  
LUCKNOW METRO RAIL CORPORATION LTD.  
KNPDD01-IIT KANPUR-NAUBASTA CORRIDOR-1

(\*) PROVIDED BY CIVIL CONTRACTOR

NO OBJECTION FROM LMRC	PREPARED	NAME	SIGNATURE	DRAWING TITLE
				POLYTECHNIC DEPOT-1
				AUTO COACH WASHING PLANT- GENERAL ARRANGEMENT DRAWING
				SECTIONS- BB', CC', DD', EE', FF' & DETAILS- A, B
				SCALE 1:1000 DATE OF ISSUE 19-09-19 STAGE TENDER DRAWING
				DRG NO. KNPDD01-TDR-DP1-ARC-PLN-91401 REV. R0



DETAIL DESIGN CONSULTANT  
**SYSTRA**  
 SYSTRA MVA CONSULTING (INDIA) PVT. LTD.  
 VATIKA MINDSCAPES, TOWER-B, 12/3,  
 MATHURA ROAD, NH-2, SECTOR-27/D,  
 FARIDABAD, HARYANA-121013  
 PH. 0129 668 5600  
 SUBSIDIARY OF:  
 SYSTRA S.A. - 5 AVENUE DU COQ - PARIS 75009

REV.	PARTICULARS	DRN.	CHD.	VER.	DATE

ARCHITECTURE







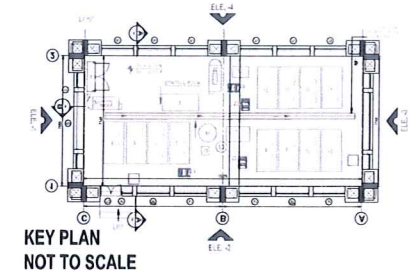
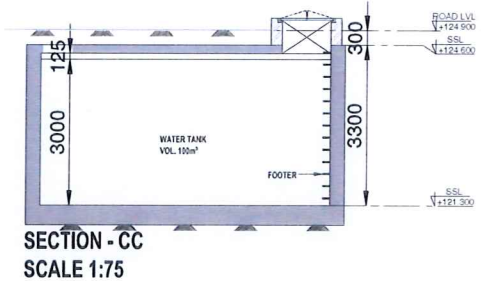
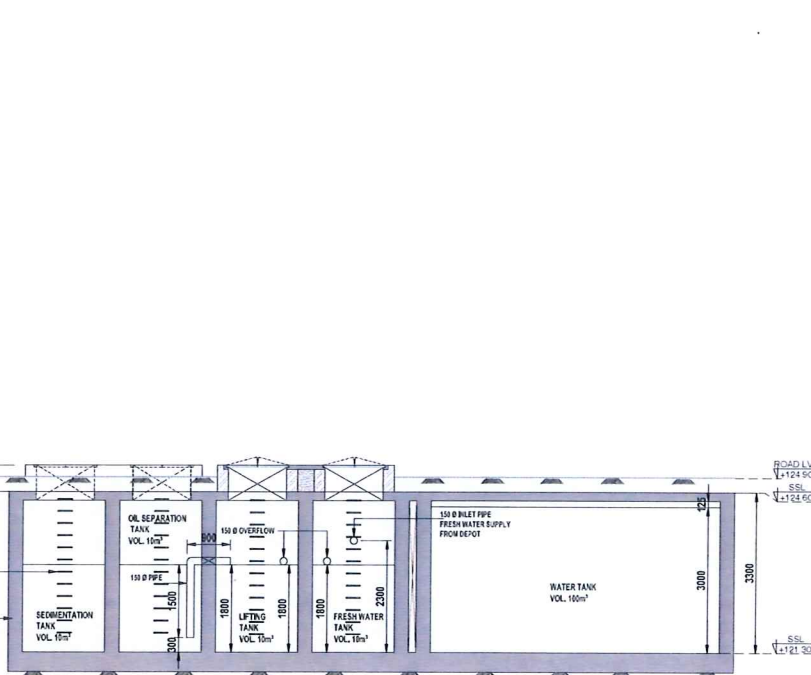
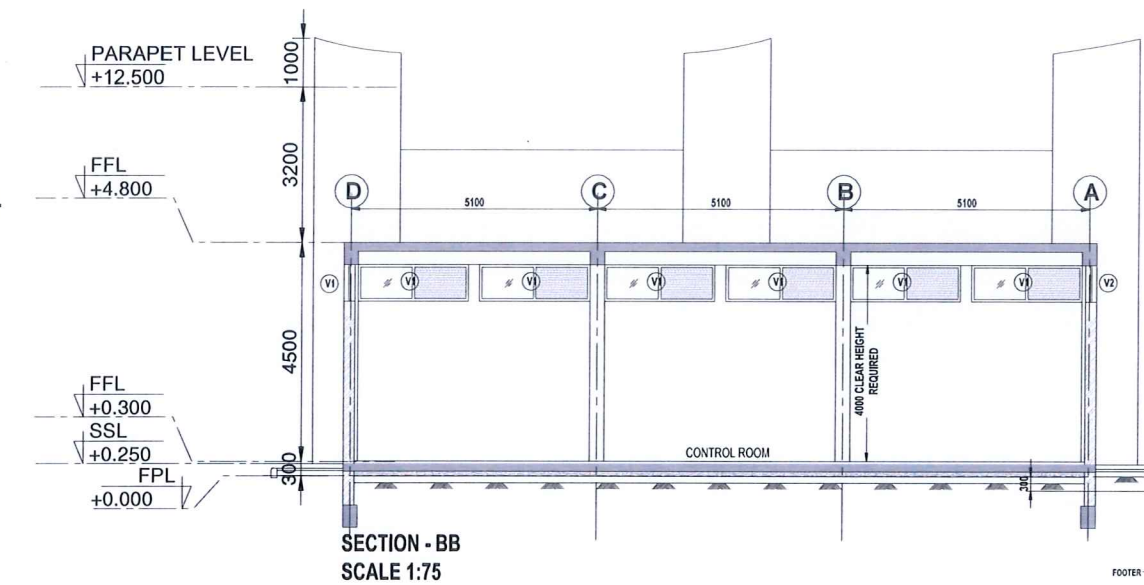
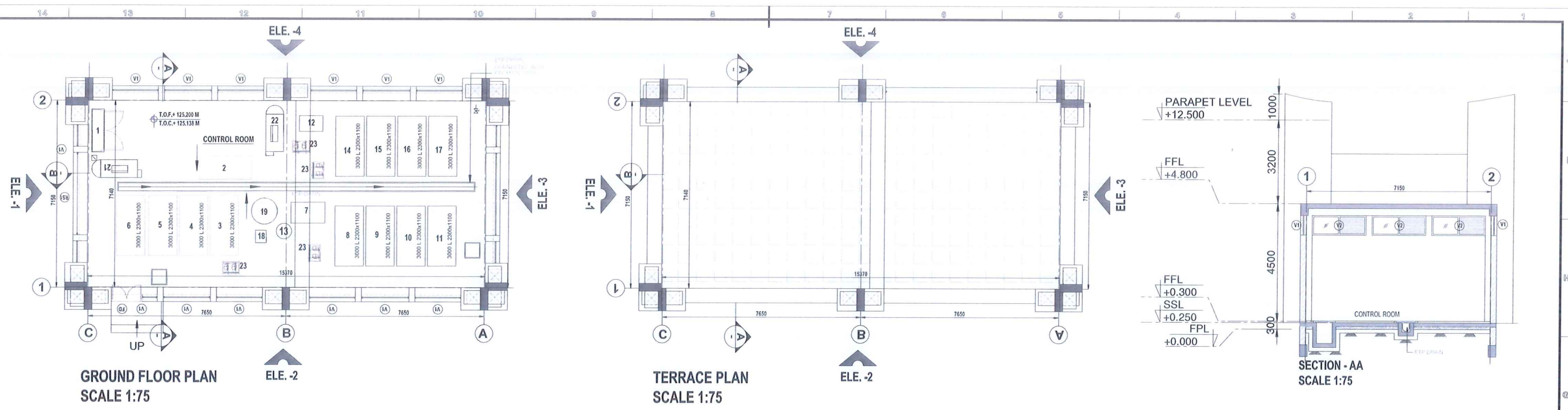

- GENERAL NOTES :-**
1. ALL DIMENSIONS ARE IN MILLIMETERS & LEVELS ARE IN METERS UNLESS MENTIONED OTHERWISE
  2. ALL DIMENSIONS ARE TO BE READ AND NOT TO BE MEASURED.
  3. THIS DRAWING MUST BE READ IN CONJUNCTION WITH ALL RELEVANT ARCHITECTURAL, STRUCTURAL, PLUMBING, FIRE FIGHTING, ELECTRICAL AND TRAFFIC MANAGEMENT DRAWINGS.
  4. ANY DISCREPANCIES MUST BE BROUGHT UP TO THE NOTICE OF THE CONSULTANT.

- NOTES :-**
1. STRUCTURAL ARRANGEMENT PRESENTED ON THE DRAWING IS INDICATIVE, REFER STRUCTURAL DRAWINGS FOR THE SAME.
  2. ROOF PROFILES AND HEIGHTS SHOWN ON THE DRAWINGS ARE INDICATIVE, SAME SHALL BE DETAILED AT LATER STAGE.
  3. MEP REQUIREMENTS THUS INDICATED ON LAYOUTS SHALL BE DETAILED AT LATER STAGE.
  4. LOCATIONS OF FHC, FIRE EXTINGUISHERS AND CUTOUTS WILL BE UPDATED AT LATER STAGES.
  5. THE DRAWINGS HAVE BEEN DEVELOPED WITH RESPECT TO DPR AND LMRC REQUIREMENTS.
  6. THE RAIL LEVELS INDICATED ON DRAWINGS ARE SUBJECT TO APPROVAL BY RELEVANT DISCIPLINES/LMRC. +128.6 (40.00) HAS BEEN TAKEN AS RAIL LEVEL IN THE DRAWINGS.
  7. ROAD LAYOUT/PEDESTRIAN MOVEMENT/CAR PARKING SHOWN ON THE LAYOUT ARE TENTATIVE, SUBJECT TO APPROVAL BY RELEVANT DISCIPLINE/LMRC.
  8. TRACK C/C DIMENSIONS PROVIDED RELATED TO THIRD RAIL SYSTEM REQUIREMENTS. REFER MOM @ SYSTRA/KNPDD-01-MOM-00010, DATED - 07-08-2019
  9. NO. OF TOILETS AND FIXTURES SHOWN ON THE DRAWINGS ARE INDICATIVE. SHALL BE DETAILED AT A LATER STAGE.
  10. THE BRACKET SIZES AND LEVELS FOR OVERHEAD CRANES SHALL BE AS VENDOR DETAILS AND DRAWINGS.
  11. LIFT PIT DEPTH/WELL SIZES SHALL BE FIXED AS VENDOR DETAIL AND DRAWINGS.
  12. ROOM SIZES, HEIGHTS AND DOOR OPENINGS SHALL BE CONFIRMED BY RELEVANT DISCIPLINES OF ENGINEERING.
  13. SITE LEVELS SHALL BE UPDATED WITH RESPECT TO SURVEY DRAWINGS AT A LATER STAGE.
  14. WINDOW GLAZING OPENING SIZES ARE INDICATIVE, SHALL BE DETAILED AT A LATER STAGE.
  15. SIZES OF ALL MEP SYSTEMS/TRACKS/OTHER DISCIPLINES, MUST BE VERIFIED BY RELEVANT DISCIPLINES.
  16. ALL MATERIALS/FINISHES THUS MENTIONED ON THE DRAWINGS ARE SUBJECT TO LMRC REVIEW AND APPROVAL.
  17. ALL PEB PROFILES/STRUCTURAL SUPPORT SYSTEM SHOWN ON THE DRAWINGS ARE INDICATIVE ONLY. DETAIL TO BE PROVIDED BY THE PEB CONSULTANT.

REV.	PARTICULARS	DRN.	CHD.	VER.	DATE
R3	First Issue	P.KUMAR	N.CHATURVEDI	ASHISH	19-09-19

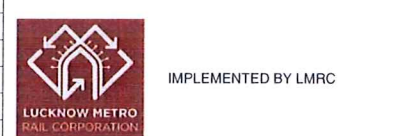

DETAIL DESIGN CONSULTANT  
**SYSTRA** MVA CONSULTING (INDIA) PVT. LTD.  
 VATIKA MINDSCAPES, TOWER-B, 12/3,  
 MATHURA ROAD, NH-2, SECTOR-27/D,  
 FARIDABAD, HARYANA-121013  
 PH: 0129 658 5600  
 SUBSIDIARY OF:  
 SYSTRA S.A. - 5 AVENUE DU COQ - PARIS 75009

NO OBJECTION FROM LMRC	PREPARED	NAME	SIGNATURE
	DRAWN BY	P.KUMAR	
	DESIGNED BY	N.AMALIK	
	CHECKED BY	N.CHATURVEDI	
	APPROVED BY	ASHISH	

NOTICE OF 'NO OBJECTIONS' FROM EMPLOYER			
NOTICE OF NO OBJECTION FROM EMPLOYER IS BEING ACCORDED FOR DESIGN PRINCIPLES HOWEVER THE OVERALL RESPONSIBILITY FOR THE DESIGN ACCURACY LIES WITH THE DETAIL DESIGN CONSULTANT.			
	REMARKS	DATE	SIGNATURE
DY CA - LMRC	REVIEWED & NO OBJECTION MAY BE CONVEYED TO THE CONTRACTOR		
DY CE - LMRC	BASED ON STAMPED ABOVE THE NO OBJECTION IS ISSUED FOR EXECUTION PURPOSE		
CPM - LMRC			
PROJECT TITLE LUCKNOW METRO RAIL CORPORATION LTD. KNPDD01-IIT KANPUR-NAUBASTA CORRIDOR-1 (IMPLEMENTED BY LMRC)			
DRAWING TITLE POLYTECHNIC DEPOT-1 AUTO COACH WASHING PLANT PLAN & SECTIONS A,B,C			
SCALE	1:50	DATE OF ISSUE	19-09-19
STAGE	TENDER DRAWING		
DRG. NO.	KNPDD01-TDR-DP1-ARC-PLN-01403		
REV.	R0		



ARCHITECTURE



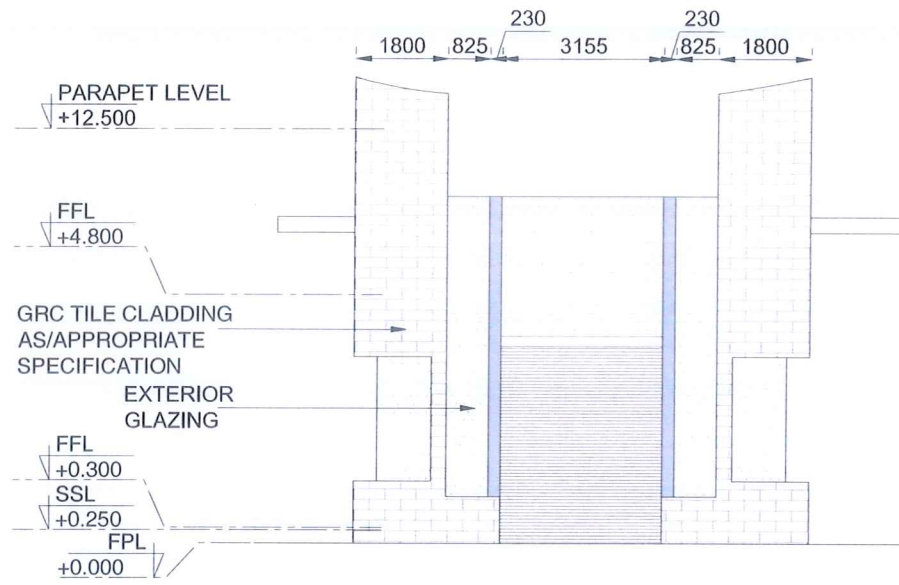

ELEVATION - 1

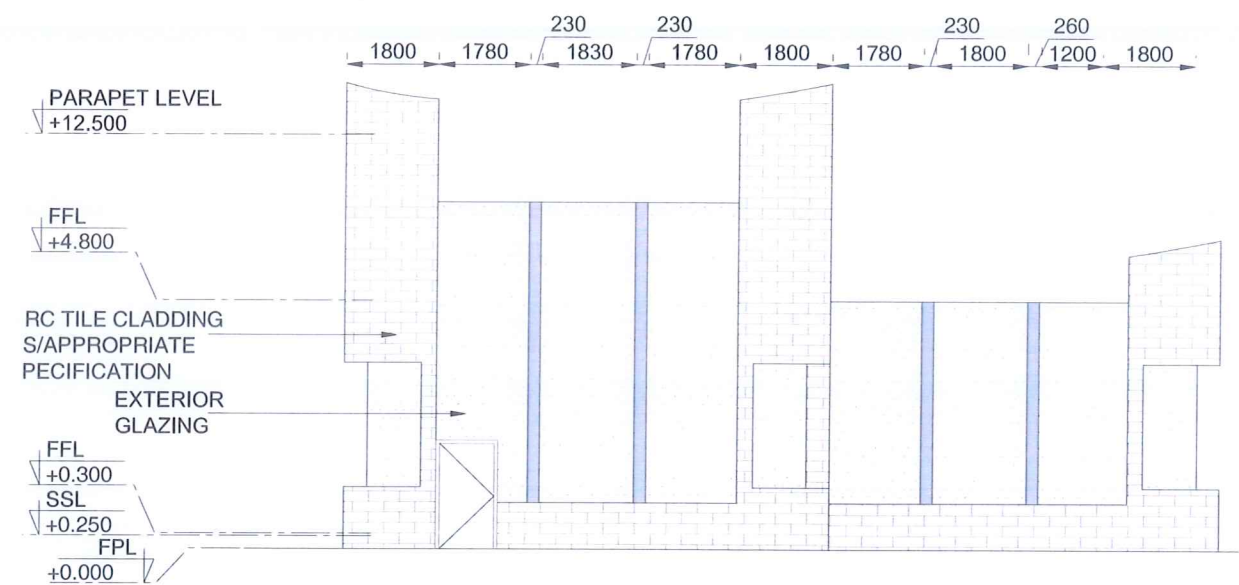

ELEVATION - 2

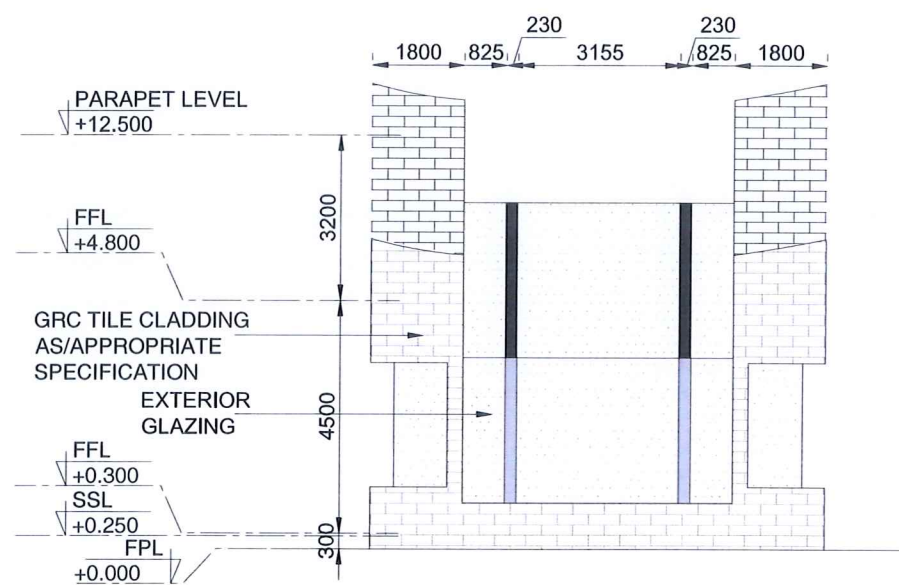

ELEVATION - 3

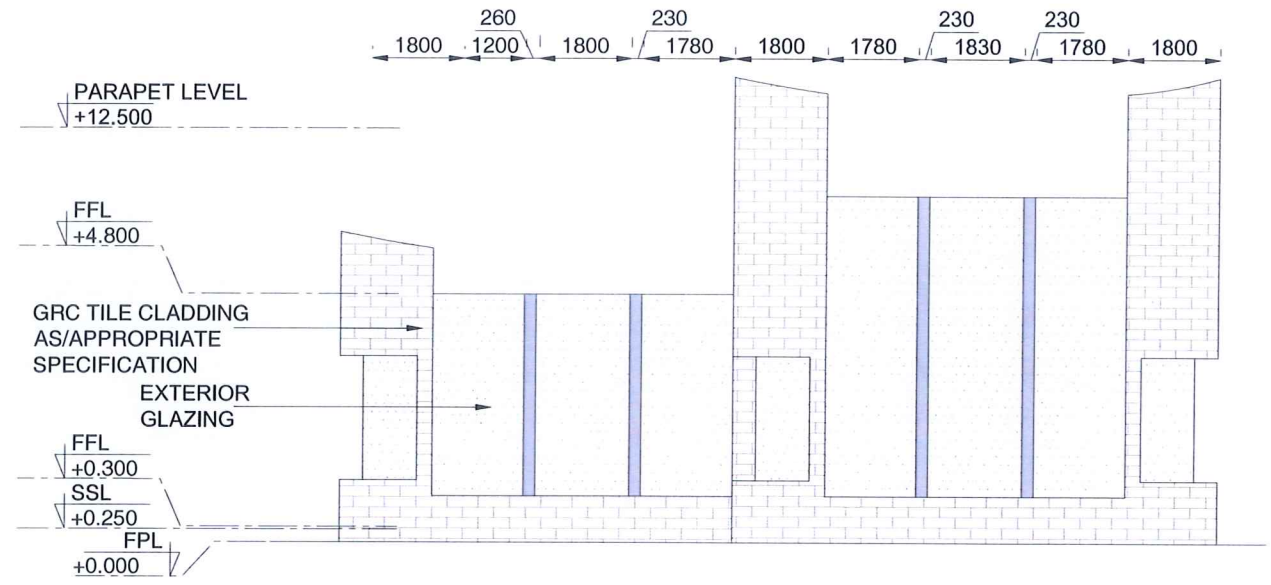

ELEVATION - 4

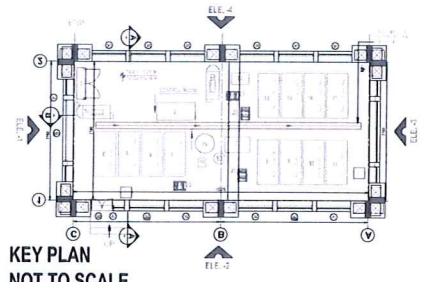

- GENERAL NOTES :-**
- ALL DIMENSIONS ARE IN MILLIMETERS & LEVELS ARE IN METERS UNLESS MENTIONED OTHERWISE
  - ALL DIMENSIONS ARE TO BE READ AND NOT TO BE MEASURED
  - THIS DRAWING MUST BE READ IN CONJUNCTION WITH ALL RELEVANT ARCHITECTURAL, STRUCTURAL, PLUMBING, FIRE FIGHTING, ELECTRICAL AND TRAFFIC MANAGEMENT DRAWINGS
  - ANY DISCREPANCIES MUST BE BROUGHT UP TO THE NOTICE OF THE CONSULTANT.

- NOTES :-**
- STRUCTURAL ARRANGEMENT PRESENTED ON THE DRAWING IS INDICATIVE, REFER STRUCTURAL DRAWINGS FOR THE SAME.
  - ROOF PROFILES AND HEIGHTS SHOWN ON THE DRAWINGS ARE INDICATIVE, SAME SHALL BE DETAILED AT LATER STAGE.
  - MEP REQUIREMENTS THUS INDICATED ON LAYOUTS SHALL BE DETAILED AT LATER STAGE.
  - LOCATIONS OF FIRE, FIRE EXTINGUISHERS AND CUTOUPS WILL BE UPDATED AT LATER STAGES.
  - THE DRAWINGS HAVE BEEN DEVELOPED WITH RESPECT TO DPR AND LMRC REQUIREMENTS.
  - THE RAIL LEVELS INDICATED ON DRAWINGS ARE SUBJECT TO APPROVAL BY RELEVANT DISCIPLINES/LMRC. +128.4 (0.00M) HAS BEEN TAKEN AS RAIL LEVEL IN THE DRAWINGS.
  - ROAD LAYOUT/PEDESTRIAN MOVEMENT/CAR PARKING SHOWN ON THE LAYOUT ARE TENTATIVE, SUBJECT TO APPROVAL BY RELEVANT DISCIPLINE/LMRC.
  - TRACK C/C DIMENSIONS PROVIDED RELATED TO THIRD RAIL SYSTEM REQUIREMENTS. REFER MOM 0-SYST-KNPDD-01-MOM-00019, DATED - 07.02.2019
  - NO. OF TOILETS AND FIXTURES SHOWN ON THE DRAWINGS ARE INDICATIVE. SHALL BE DETAILED AT A LATER STAGE.
  - THE BRACKET SIZES AND LEVELS FOR OVERHEAD CRANES SHALL BE AS VENDOR DETAILS AND DRAWINGS.
  - LIFT PIT DEPTH/WELL SIZES SHALL BE FIXED AS VENDOR DETAIL AND DRAWINGS.
  - ROOM SIZES, HEIGHTS AND DOOR OPENINGS SHALL BE CONFIRMED BY RELEVANT DISCIPLINES OF ENGINEERING.
  - SITE LEVELS SHALL BE UPDATED WITH RESPECT TO SURVEY DRAWINGS AT A LATER STAGE.
  - WINDOW/GLAZING OPENING SIZES ARE INDICATIVE, SHALL BE DETAILED AT A LATER STAGE.
  - SIZES OF ALL MEP/ SYSTEMS/TRACKS-OTHER DISCIPLINES, MUST BE VERIFIED BY RELEVANT DISCIPLINES.
  - ALL MATERIALS/ FINISHES THUS MENTIONED ON THE DRAWINGS ARE SUBJECT TO LMRC REVIEW AND APPROVAL.
  - ALL MEP PROFILES/STRUCTURAL SUPPORT SYSTEM SHOWN ON THE DRAWINGS ARE INDICATIVE ONLY. DETAIL TO BE PROVIDED BY THE MEP CONSULTANT.

REV.	PARTICULARS	DRN.	CHD.	VER.	DATE
R0	First Issue	P.KUMAR	N.CHATURVEDI	ASHISH	15-09-19



**DETAIL DESIGN CONSULTANT**  
**SYSTRA**  
 SYSTRA MVA CONSULTING (INDIA) PVT. LTD.  
 VATIKA MINDSCAPES, TOWER-B, 12/3,  
 MATHURA ROAD, NH-2, SECTOR-27/D,  
 FARIDABAD, HARYANA-121013  
 PH. 0129 668 5600  
 SUBSIDIARY OF:  
 SYSTRA S.A. - 5 AVENUE DU COO - PARIS 75009

NO OBJECTION FROM LMRC	PREPARED	NAME	SIGNATURE
	DRAWN BY	P.KUMAR	<i>[Signature]</i>
	DESIGNED BY	N.A.MALIK	<i>[Signature]</i>
	CHECKED BY	N.CHATURVEDI	<i>[Signature]</i>
	APPROVED BY	ASHISH	<i>[Signature]</i>

NOTICE OF 'NO OBJECTIONS' FROM EMPLOYER			
NOTICE OF NO OBJECTION FROM EMPLOYER IS BEING ACCORDED FOR DESIGN PRINCIPLES HOWEVER THE OVERALL RESPONSIBILITY FOR THE DESIGN ACCURACY LIES WITH THE DETAIL DESIGN CONSULTANT.			
	REMARKS	DATE	SIGNATURE
DY CA - LMRC	REVIEWED & NO OBJECTION MAY BE CONVEYED TO THE CONTRACTOR		
DY CE - LMRC	BASED ON STAMPED ABOVE THE NO OBJECTION		
CPM - LMRC	IS ISSUED FOR EXECUTION PURPOSE		
PROJECT TITLE LUCKNOW METRO RAIL CORPORATION LTD. KNPDD01-IIT KANPUR-NAUBASTA CORRIDOR-1			
DRAWING TITLE POLYTECHNIC DEPOT-1 AUTO COACH WASHING PLANT ELEVATIONS - 1,2,3,4			
SCALE	1:50	DATE OF ISSUE	19-09-19
STAGE	TENDER DRAWING		
DRG NO.	KNPDD01-TDR-DP1-ARC-PLN-91404	REV.	R0



ARCHITECTURE



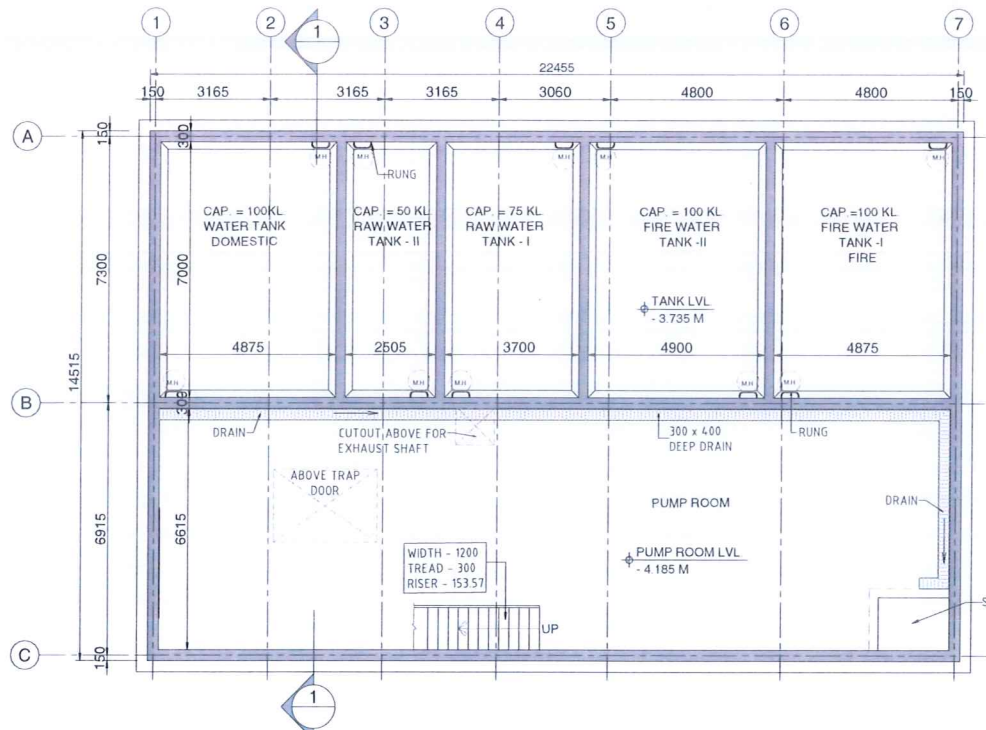

LOWER LEVEL PLAN

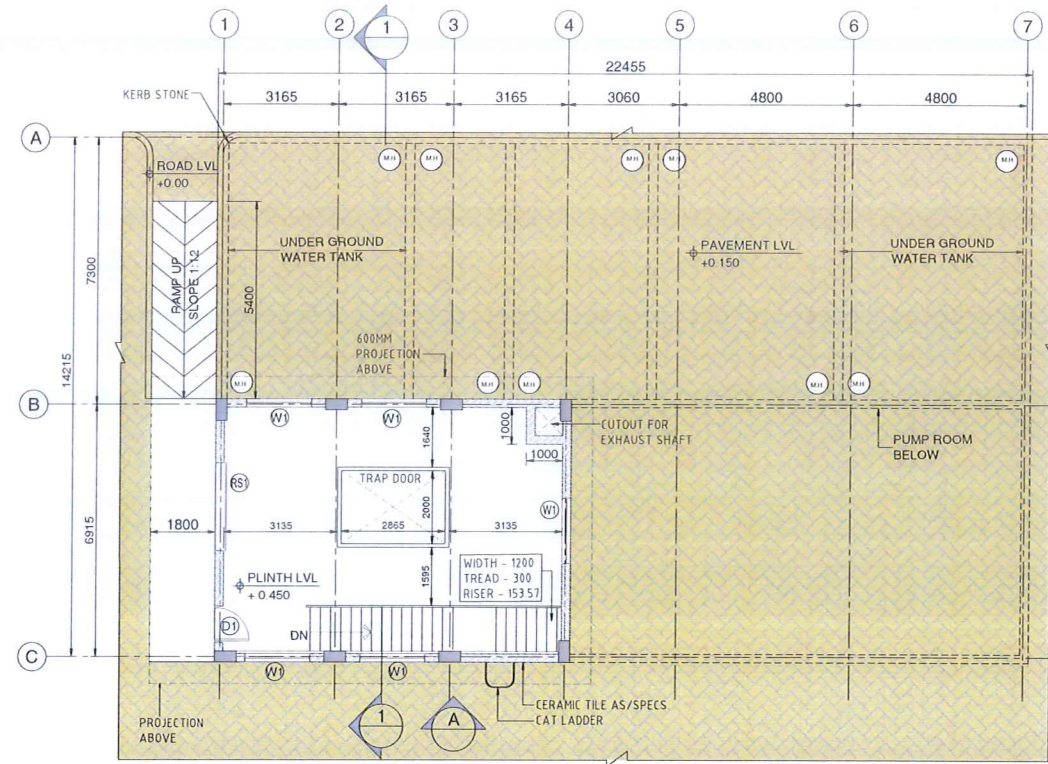

UPPER LEVEL PLAN

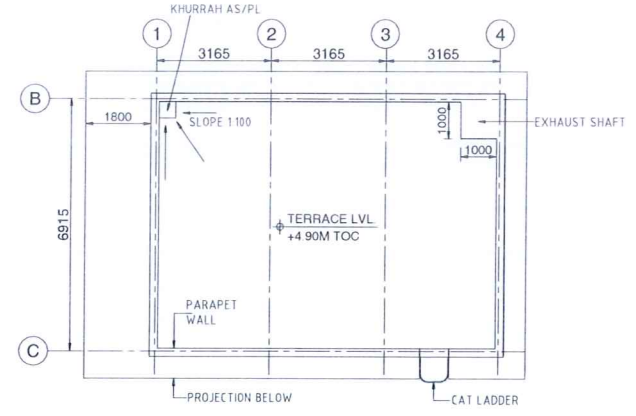

TERRACE LEVEL PLAN

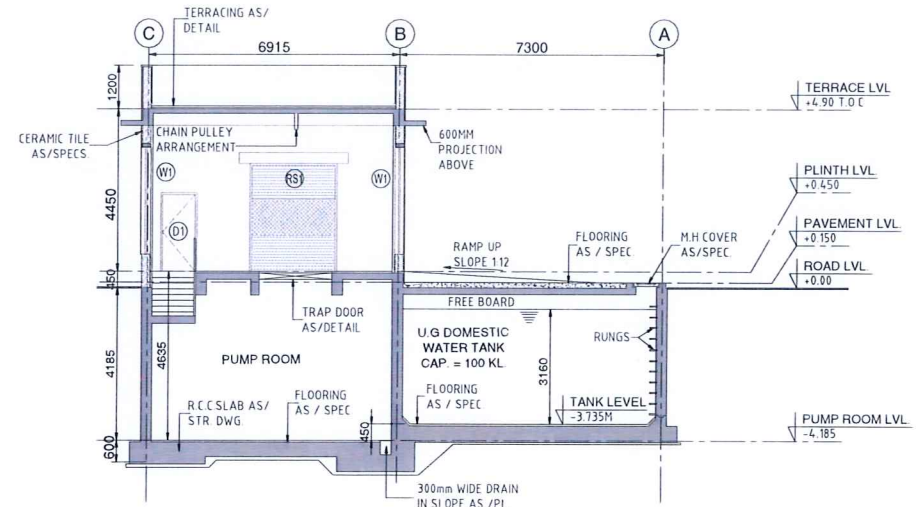

SECTION 1

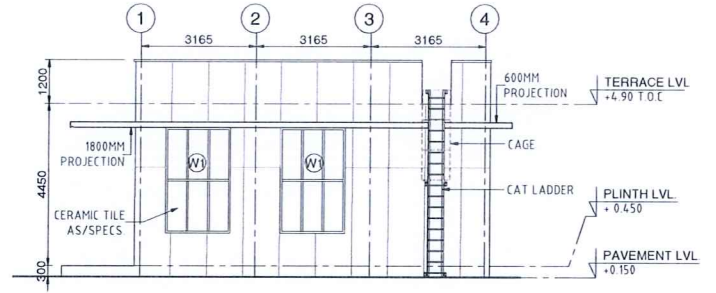

ELEVATION A

KEY PLAN: NTS

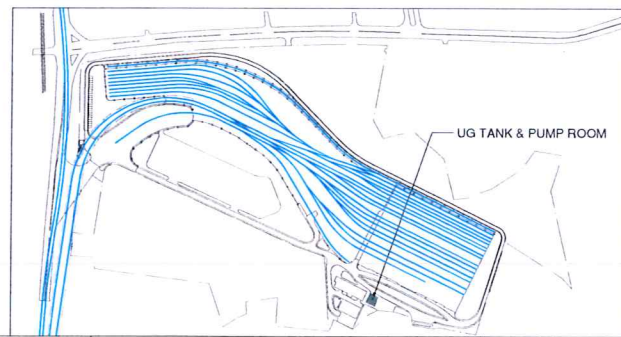

- ABBREVIATIONS :-**  
 LT- LIFT  
 ST- STAIRCASE
- SPECIAL NOTES :-**  
 1. THESE DRAWINGS ARE ONLY FOR UNDERSTANDING OF SCOPE OF THE WORK. IT IS NOT THE FINAL DOCUMENT FOR CONSTRUCTION ACTIVITIES.  
 2. ALL SUPPORTING STRUCTURES REQUIRED FOR CABLE TRAYS, RACEWAYS, BRACKETS ARE SCOPE OF THIS TENDER.  
 3. THE SQUARE METER RATE MENTIONED IN BOQ IS INCLUSIVE OF ALL SUPPORTING BRACKETS, HANGERS REQUIRED FOR CABLE TRAYS, RACEWAYS ETC. NO EXTRA PAYMENT WILL BE MADE.
- NOTES :-**  
 1. STRUCTURAL ARRANGEMENT PRESENTED ON THE DRAWING IS INDICATIVE, REFER STRUCTURAL DRAWINGS FOR THE SAME.  
 2. ROOF PROFILES AND HEIGHTS SHOWN ON THE DRAWINGS ARE INDICATIVE, SAME SHALL BE DETAILED AT LATER STAGE.  
 3. MEP REQUIREMENTS THIS INDICATED ON LAYOUTS SHALL BE DETAILED AT LATER STAGE.  
 4. LOCATIONS OF FIC, FIRE EXTINGUISHERS AND CUTOUTS WILL BE UPDATED AT LATER STAGES.  
 5. THE DRAWINGS HAVE BEEN DEVELOPED WITH RESPECT TO DPR AND LMRC REQUIREMENTS.  
 6. THE RAIL LEVELS INDICATED ON DRAWINGS ARE SUBJECT TO APPROVAL BY RELEVANT DISCIPLINES/LMRC.  
 7. ROAD LAYOUT/PEDESTRIAN MOVEMENT/CAR PARKING SHOWN ON THE LAYOUT ARE TENTATIVE, SUBJECT TO APPROVAL BY RELEVANT DISCIPLINE/LMRC.  
 8. TRACK C/C DIMENSIONS PROVIDED RELATED TO THIRD RAIL SYSTEM REQUIREMENTS, REFER MOM 0-SYST-KNPDD-01-MOM-00010, DATED - 07.08.2019  
 9. NO. OF TOILETS AND FIXTURES SHOWN ON THE DRAWINGS ARE INDICATIVE. SHALL BE DETAILED AT A LATER STAGE.  
 10. THE BRACKET SIZES AND LEVELS FOR OVERHEAD CRANES SHALL BE AS VENDOR DETAILS AND DRAWINGS.  
 11. LIFT PIT DEPTH/WELL SIZES SHALL BE FIXED AS VENDOR DETAIL AND DRAWINGS.  
 12. ROOM SIZES, HEIGHTS AND DOOR OPENINGS SHALL BE CONFIRMED BY RELEVANT DISCIPLINES OF ENGINEERING.  
 13. SITE LEVELS SHALL BE UPDATED WITH RESPECT TO SURVEY DRAWINGS AT A LATER STAGE.  
 14. WINDOW/GLAZING OPENING SIZES ARE INDICATIVE, SHALL BE DETAILED AT A LATER STAGE.  
 15. SIZES OF ALL MEP SYSTEMS/TRACKS/OTHER DISCIPLINES, MUST BE VERIFIED BY RELEVANT DISCIPLINES.  
 16. ALL MATERIALS/FINISHES THIS MENTIONED ON THE DRAWINGS ARE SUBJECT TO LMRC REVIEW AND APPROVAL.  
 17. ALL PEB PROFILES/STRUCTURAL SUPPORT SYSTEM SHOWN ON THE DRAWINGS ARE INDICATIVE ONLY. DETAIL TO BE PROVIDED BY THE PEB CONSULTANT.
- GENERAL NOTES :-**  
 1. ALL DIMENSIONS ARE IN MILLIMETERS & LEVELS ARE IN METERS UNLESS MENTIONED OTHERWISE  
 2. ALL DIMENSIONS ARE TO BE READ AND NOT TO BE MEASURED.  
 3. THIS DRAWING MUST BE READ IN CONJUNCTION WITH ALL RELEVANT ARCHITECTURAL, STRUCTURAL, PLUMBING, FIRE FIGHTING, ELECTRICAL AND TRAFFIC MANAGEMENT DRAWINGS.  
 4. ANY DISCREPANCIES MUST BE BROUGHT UP TO THE NOTICE OF THE CONSULTANT.

**SCHEDULE OF OPENINGS**  
 NOTE: ALL SILL AND LINTEL LEVELS ARE TO BE TAKEN FROM FINISHED FLOOR OF RESPECTIVE ROOM.

S.No	Type	Width	Sill Lvl	Lintel Lvl	Remarks
1	D1	1000	0.00	2.150	
2	RS1	2400	0.00	3.000	
3	W1	1800	0.90	3.700	
4	W2	700	0.90	3.700	
5	W3	1000	0.90	3.700	

**LEGEND**

	TRACK C
	230 MM BRICK WALL
	R.C.C./ COLUMN
	SECTION/ ELEVATION NAME
	DRAWING NUMBER

DETAIL DESIGN CONSULTANT  
 SYSTRA MVA CONSULTING (INDIA) PVT. LTD.  
 VATIKA MINDSCAPES, TOWER-B, 12/3,  
 MATHURA ROAD, NH-2, SECTOR-27/D,  
 FARIDABAD, HARYANA-121013  
 PH: 0129 668 5600  
 SUBSIDIARY OF:  
 SYSTRA S.A. - 5 AVENUE DU COQ - PARIS 75009

NO OBJECTION FROM LMRC

PREPARED

DRAWN BY

DESIGNED BY

CHECKED BY

APPROVED BY

NOTICE OF 'NO OBJECTIONS' FROM EMPLOYER

NOTICE OF NO OBJECTION FROM EMPLOYER IS BEING ACCORDED FOR DESIGN PRINCIPLES HOWEVER THE OVERALL RESPONSIBILITY FOR THE DESIGN ACCURACY LIES WITH THE DETAIL DESIGN CONSULTANT.

REMARKS	DATE	SIGNATURE
DY CA - LMRC REVIEWED & NO OBJECTION MAY BE CONVEYED TO THE CONTRACTOR		
DY CE - LMRC BASED ON STAMPED ABOVE THE NO OBJECTION IS ISSUED FOR EXECUTION PURPOSE		
CPM - LMRC		

PROJECT TITLE  
**LUCKNOW METRO RAIL CORPORATION LTD.**  
 KNPDD01-IIT KANPUR-NAUBASTA CORRIDOR-1

(IMPLEMENTED BY LMRC)

NAME	SIGNATURE	DRAWING TITLE
P.KUMAR		POLYTECHNIC DEPOT-1
N.AMALIK		UG TANK & PUMP ROOM
N.CHATURVEDI		PLANS, ELEVATION & SECTION
ASHISH		

SCALE 1:100 DATE OF ISSUE 19-09-19 STAGE TENDER DRAWING

DRG NO. KNPDD01-TDR-DP1-ARC-PLN-91501 REV R0



IMPLEMENTED BY LMRC



ARCHITECTURE



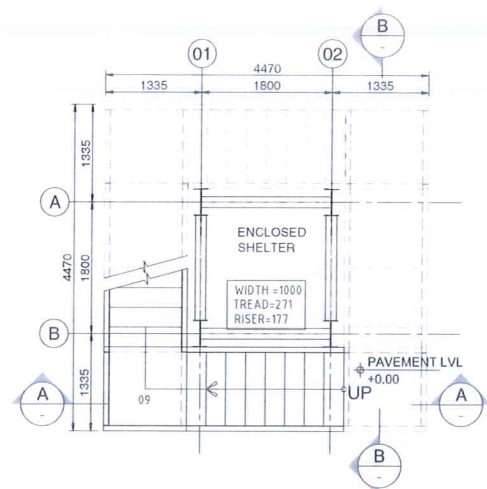

GROUND FLOOR PLAN @ ±0.00

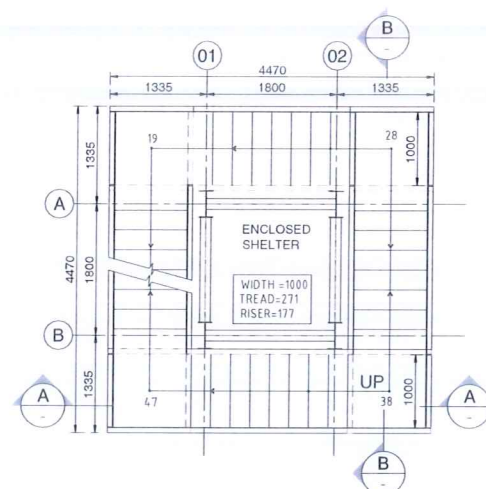

MID. LVL PLAN @ +6.40 M

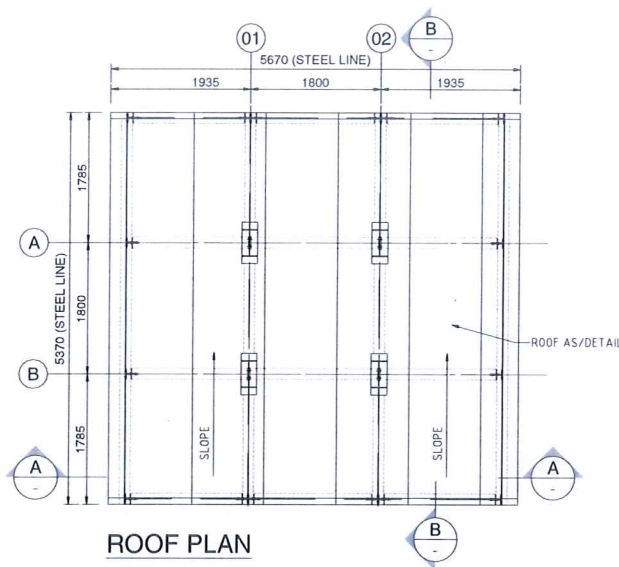

ROOF PLAN

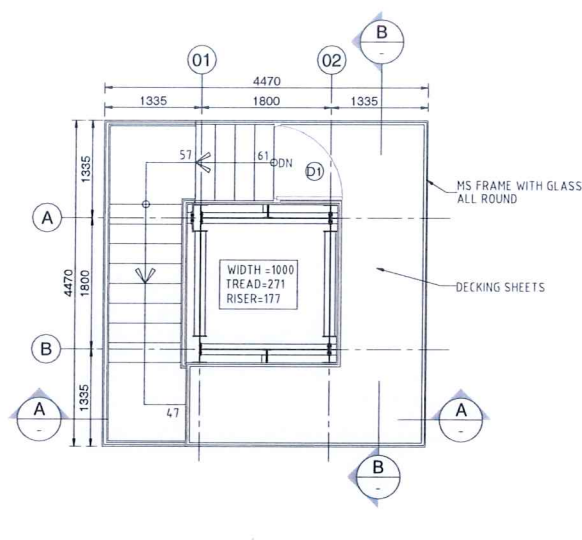

TERRACE FLOOR PLAN @ +10.50M

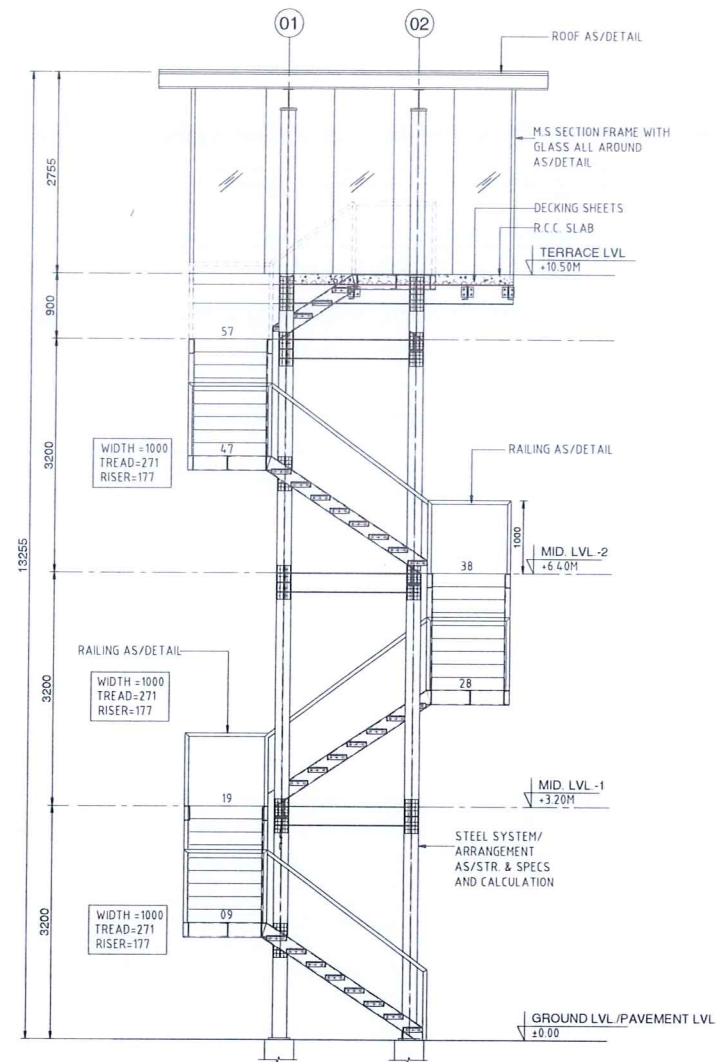

SECTION AA

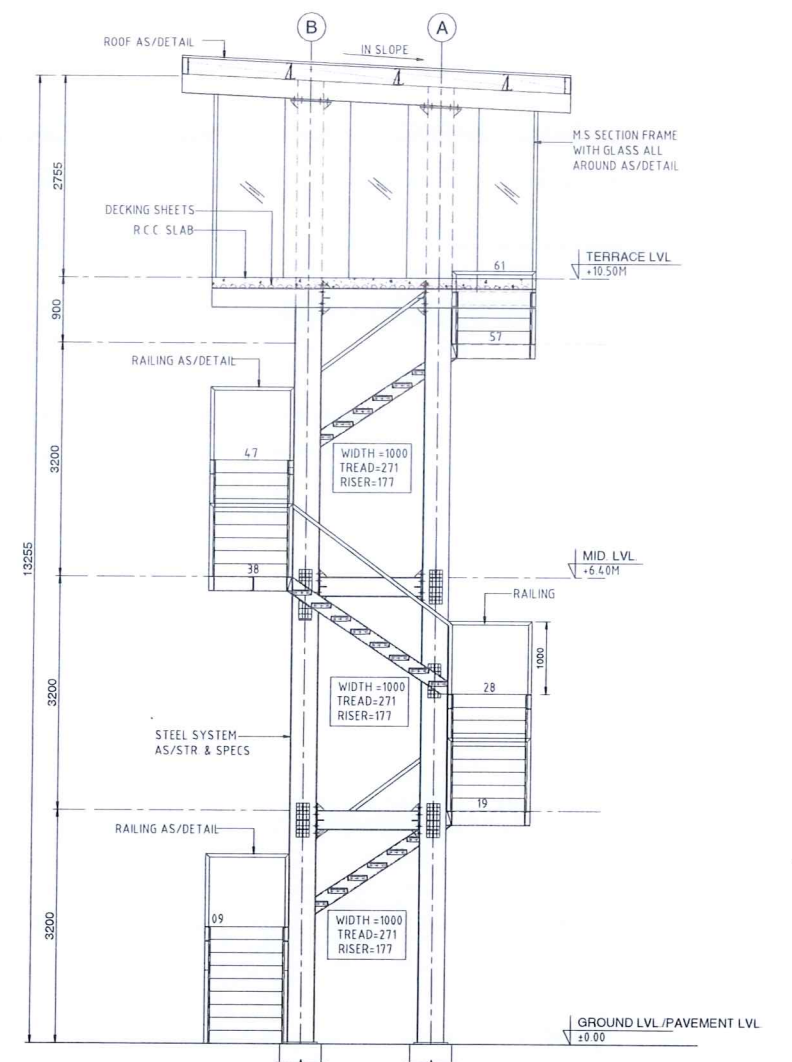

SECTION BB

KEY PLAN: NTS

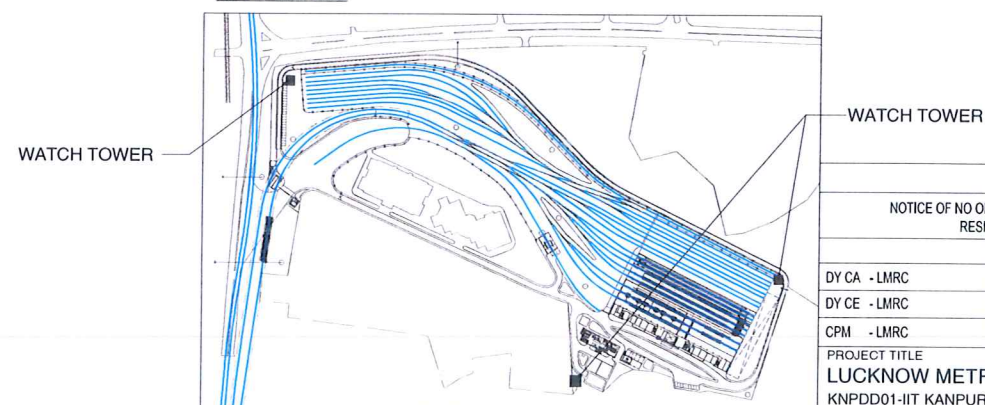

- GENERAL NOTES :-**
1. ALL DIMENSIONS ARE IN MILLIMETERS & LEVELS ARE IN METERS UNLESS MENTIONED OTHERWISE
  2. ALL DIMENSIONS ARE TO BE READ AND NOT TO BE MEASURED.
  3. THIS DRAWING MUST BE READ IN CONJUNCTION WITH ALL RELEVANT ARCHITECTURAL, STRUCTURAL, PLUMBING, FIRE FIGHTING, ELECTRICAL AND TRAFFIC MANAGEMENT DRAWINGS
  4. ANY DISCREPANCIES MUST BE BROUGHT UP TO THE NOTICE OF THE CONSULTANT.

- SPECIAL NOTES :-**
1. THESE DRAWINGS ARE ONLY FOR UNDERSTANDING THE SCOPE OF THE WORK. IT IS NOT THE FINAL DOCUMENTATION FOR CONSTRUCTION ACTIVITIES.
  2. ALL SUPPORTING MEMBERS REQUIRED FOR CABLE TRAYS, RACEWAYS, ETC ARE INCLUDED IN SQM RATE MENTIONED IN PEB BOQ. NO EXTRA PAYMENT WILL BE MADE FOR ANY SUPPORT MEMBER.

**SCHEDULE OF OPENINGS**

NOTE: ALL SILL AND LINTEL LEVELS ARE TO BE TAKEN FROM FINISHED FLOOR OF RESPECTIVE ROOM

S.No	Type	Width	Sill Lvl	Lintel Lvl	Remarks
1.	D1	1100	0.00	2150	



IMPLEMENTED BY LMRC

DETAIL DESIGN CONSULTANT

**SYSTRA**  
 SYSTRA MVA CONSULTING (INDIA) PVT. LTD.  
 VATIKA MINDSCAPES, TOWER-B, 12/3,  
 MATHURA ROAD, NH-2, SECTOR-27/D,  
 FARIDABAD, HARYANA-121013  
 PH. 0129 668 5600  
 SUBSIDIARY OF:  
 SYSTRA S.A. - 5 AVENUE DU COQ - PARIS 75009

NO OBJECTION FROM LMRC

PREPARED

DRAWN BY

DESIGNED BY

CHECKED BY

APPROVED BY

NAME

SIGNATURE

DRAWING TITLE

POLYTECHNIC DEPOT-1

WATCH TOWER

PLANS & SECTIONS

SCALE 1:50

DATE OF ISSUE 19-09-19

STAGE TENDER DRAWING

DRG. NO. KNPDD01-TDR-DP1-ARC-PLN-91601

REV. R0

WATCH TOWER

NOTICE OF 'NO OBJECTIONS' FROM EMPLOYER

NOTICE OF NO OBJECTION FROM EMPLOYER IS BEING ACCORDED FOR DESIGN PRINCIPLES HOWEVER THE OVERALL RESPONSIBILITY FOR THE DESIGN ACCURACY LIES WITH THE DETAIL DESIGN CONSULTANT.

REMARKS	DATE	SIGNATURE
DY CA - LMRC REVIEWED & NO OBJECTION MAY BE CONVEYED TO THE CONTRACTOR		
DY CE - LMRC BASED ON STAMPED ABOVE THE NO OBJECTION IS ISSUED FOR EXECUTION PURPOSE		
CPM - LMRC		

PROJECT TITLE  
**LUCKNOW METRO RAIL CORPORATION LTD.**  
 KNPDD01-IIT KANPUR-NAUBASTA CORRIDOR-1

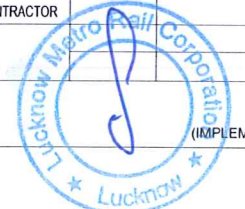

(IMPLEMENTED BY LMRC)

ARCHITECTURE



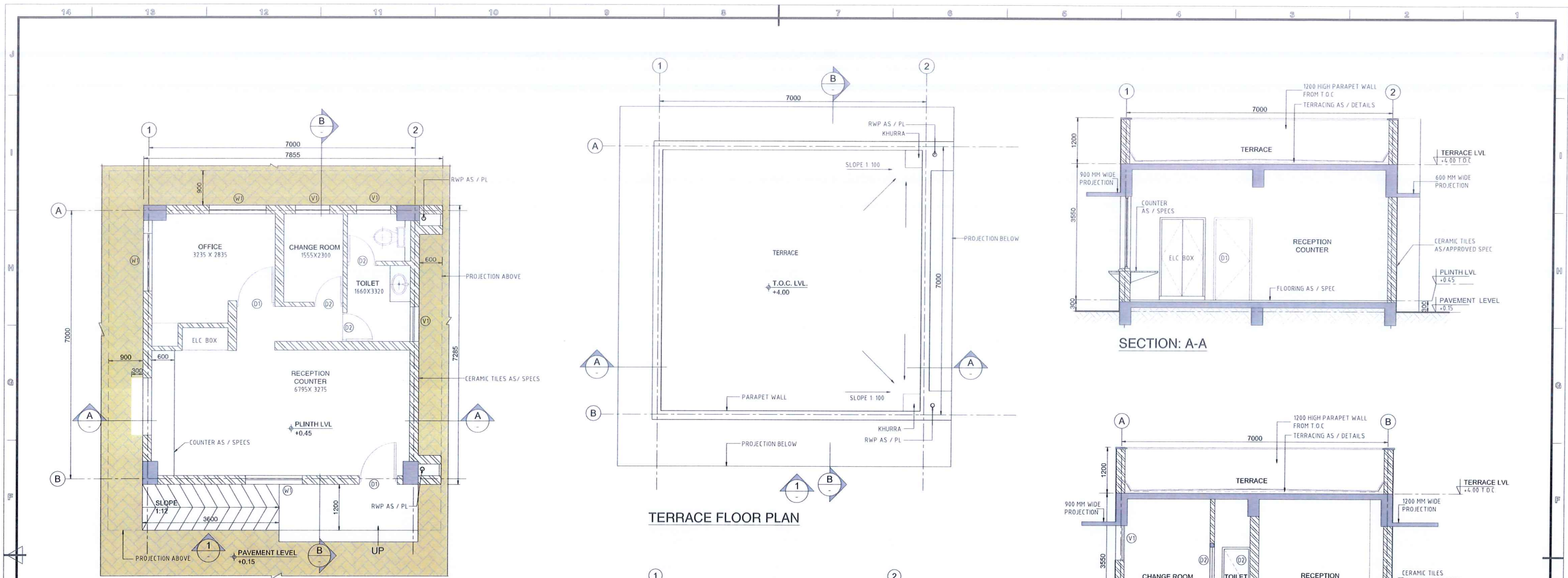

**ABBREVIATIONS :-**  
 LT- LIFT  
 ST- STAIRCASE

**SPECIAL NOTES :-**  
 1. THESE DRAWINGS ARE ONLY FOR UNDERSTANDING THE SCOPE OF THE WORK. IT IS NOT THE FINAL DOCUMENTATION FOR CONSTRUCTION ACTIVITIES.  
 2. ALL SUPPORTING MEMBERS REQUIRED FOR CABLE TRAYS, RACEWAYS, ETC ARE INCLUDED IN SQM RATE MENTIONED IN PEB BOQ. NO EXTRA PAYMENT WILL BE MADE FOR ANY SUPPORT MEMBER.

**NOTES :-**  
 1. STRUCTURAL ARRANGEMENT PRESENTED ON THE DRAWING IS INDICATIVE, REFER STRUCTURAL DRAWINGS FOR THE SAME.  
 2. ROOF PROFILES AND HEIGHTS SHOWN ON THE DRAWINGS ARE INDICATIVE, SAME SHALL BE DETAILED AT LATER STAGE.  
 3. MEP REQUIREMENTS THUS INDICATED ON LAYOUTS SHALL BE DETAILED AT LATER STAGE.  
 4. LOCATIONS OF F.H.C. FIRE EXTINGUISHERS AND CUTOUPS WILL BE UPDATED AT LATER STAGES.  
 5. THE DRAWINGS HAVE BEEN DEVELOPED WITH RESPECT TO DPR AND LMRC REQUIREMENTS.  
 6. THE RAIL LEVELS INDICATED ON DRAWINGS ARE SUBJECT TO APPROVAL BY RELEVANT DISCIPLINES/LMRC. +128.6 (+0.00) HAS BEEN TAKEN AS RAIL LEVEL IN THE DRAWINGS.  
 7. ROAD LAYOUT/PEDESTRIAN MOVEMENT/CAR PARKING SHOWN ON THE LAYOUT ARE TENTATIVE, SUBJECT TO APPROVAL BY RELEVANT DISCIPLINE/LMRC.  
 8. TRACK C/C DIMENSIONS PROVIDED RELATED TO THIRD RAIL SYSTEM REQUIREMENTS. REFER MOM 0-SYST-KNDD-01-MOM-00010, DATED - 07.08.2019  
 9. NO. OF TOILETS AND FIXTURES SHOWN ON THE DRAWINGS ARE INDICATIVE. SHALL BE DETAILED AT A LATER STAGE.  
 10. THE BRACKET SIZES AND LEVELS FOR OVERHEAD CRANES SHALL BE AS/VENDOR DETAILS AND DRAWINGS.  
 11. LIFT PIT DEPTH/WELL SIZES SHALL BE FIXED AS/VENDOR DETAIL AND DRAWINGS.  
 12. ROOM SIZES, HEIGHTS AND DOOR OPENINGS SHALL BE CONFIRMED BY RELEVANT DISCIPLINES OF ENGINEERING.  
 13. SITE LEVELS SHALL BE UPDATED WITH RESPECT TO SURVEY DRAWINGS AT A LATER STAGE.  
 14. WINDOW/GLAZING OPENING SIZES ARE INDICATIVE, SHALL BE DETAILED AT A LATER STAGE.  
 15. SIZES OF ALL MEP/ SYSTEMS/TRACKS/OTHER DISCIPLINES, MUST BE VERIFIED BY RELEVANT DISCIPLINES.  
 16. ALL MATERIALS FINISHES THUS MENTIONED ON THE DRAWINGS ARE SUBJECT TO LMRC REVIEW AND APPROVAL.  
 17. ALL PEB PROFILES/STRUCTURAL SUPPORT SYSTEM SHOWN ON THE DRAWINGS ARE INDICATIVE ONLY. DETAIL TO BE PROVIDED BY THE PEB CONSULTANT.

**GROUND FLOOR PLAN**

**TERRACE FLOOR PLAN**

**SECTION: A-A**

**SECTION: B-B**

**GENERAL NOTES :-**  
 1. ALL DIMENSIONS ARE IN MILLIMETERS & LEVELS ARE IN METERS UNLESS MENTIONED OTHERWISE.  
 2. ALL DIMENSIONS ARE TO BE READ AND NOT TO BE MEASURED.  
 3. THIS DRAWING MUST BE READ IN CONJUNCTION WITH ALL RELEVANT ARCHITECTURAL, STRUCTURAL, PLUMBING, FIRE FIGHTING, ELECTRICAL AND TRAFFIC MANAGEMENT DRAWINGS.  
 4. ANY DISCREPANCIES MUST BE BROUGHT UP TO THE NOTICE OF THE CONSULTANT.

**SCHEDULE OF OPENINGS**  
 NOTE: ALL SILL AND LINTEL LEVELS ARE TO BE TAKEN FROM FINISHED OF RESPECTIVE ROOMS

S.No.	Type	Width	Sill Lvl	Lintel Lvl
1.	D	1000	0.00	2700
2.	D1	1000	0.00	2150
3.	D2	750	0.00	2150
4.	W1	1500	900	2700
5.	V1	900	1800	2700

**LEGEND**

	TRACK
	230 MM BRICK WALL
	R.C.C/ COLUMN
	SECTION/ ELEVATION NAME
	DRAWING NUMBER

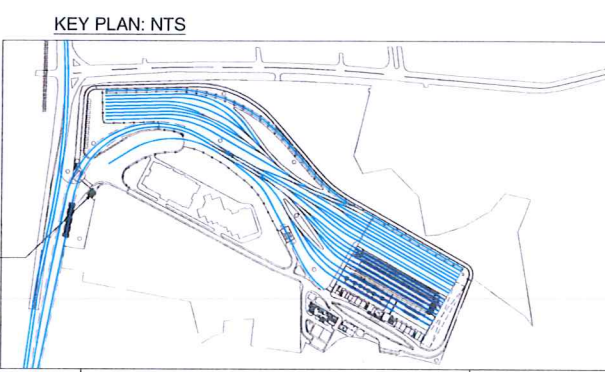

NOTICE OF 'NO OBJECTIONS' FROM EMPLOYER  
 NOTICE OF NO OBJECTION FROM EMPLOYER IS BEING ACCORDED FOR DESIGN PRINCIPLES HOWEVER THE OVERALL RESPONSIBILITY FOR THE DESIGN ACCURACY LIES WITH THE DETAIL DESIGN CONSULTANT.

REMARKS	DATE	SIGNATURE
DY CA - LMRC REVIEWED & NO OBJECTION MAY BE CONVEYED TO THE CONTRACTOR		
DY CE - LMRC BASED ON STAMPED ABOVE THE NO OBJECTION IS ISSUED FOR EXECUTION PURPOSE		
CPM - LMRC		

PROJECT TITLE  
**LUCKNOW METRO RAIL CORPORATION LTD.**  
 KNPDD01-IIT KANPUR-NAUBASTA CORRIDOR-1

NO OBJECTION FROM LMRC	PREPARED	NAME	SIGNATURE	DRAWING TITLE
				<b>POLYTECHNIC DEPOT-1</b>
	DRAWN BY	P.KUMAR		<b>TIME &amp; SECURITY OFFICE</b>
	DESIGNED BY	N.A.MALIK		<b>PLANS, ELEVATION- 1 &amp; SECTION- A,B</b>
	CHECKED BY	N.CHATURVEDI		SCALE 1:50
	APPROVED BY	ASHSH		DATE OF ISSUE 19-09-19
				STAGE TENDER DRAWING
				DRG NO. KNPDD01-TDR-DP1-ARC-PLN-91701

IMPLEMENTED BY LMRC

LUCKNOW METRO RAIL CORPORATION

REV.	PARTICULARS	DRN.	CHD.	VER.	DATE
01	Final Issue	P.KUMAR	N.CHATURVEDI	ASHSH	19-09-19

DETAIL DESIGN CONSULTANT  
**SYSTRA**  
 SYSTRA MVA CONSULTING (INDIA) PVT. LTD.  
 VATIKA MINDSCAPES, TOWER-B, 12/3,  
 MATHURA ROAD, NH-2, SECTOR-27/D,  
 FARIDABAD, HARYANA-121013  
 PH. 0129 668 5600  
 SUBSIDIARY OF:  
 SYSTRA S.A. - 5 AVENUE DU COQ - PARIS 75009

ARCHITECTURE

REV. R0



**Revised - NOTICE INVITING TENDER (NIT)**

**1.1 GENERAL**

**1.1.1 Name of Work:**

Lucknow Metro Rail Corporation (LMRC) Ltd., who has been assigned to carry out interim works for Kanpur Metro Rail Project, invites open tenders from eligible applicants, who fulfill qualification criteria as stipulated in Clause 1.1.3 of NIT, for the work, **"KNPCC-03: Civil, PEB and E&M works for construction of depot cum workshop, including structural, architectural, plumbing, drainage, external development, road works, electrical, mechanical, VAC, fire fighting, fire detection etc. at Govt. Polytechnic Depot for IIT Kanpur to Naubasta Corridor-1 of Kanpur Metro"**.

The brief scope of the work and site information is provided in Employer Requirements (Volume-3)

**1.1.2 Key details:**

Approximate cost of work	<b>INR 105.00 Crores</b>
Tender Security amount	<b>INR 1.05 Crs.</b>
Completion period of the Work	18 months
Tender documents on sale	From <b>30.08.2019 to 20.09.2019 23.09.2019</b> (between 09:00 Hrs to 17:30 Hrs) on working days
Cost of Tender documents	<b>INR 23600/- (inclusive 18% GST)</b> (In form of Demand Draft in favour of <b>"Lucknow Metro Rail Corporation Ltd."</b> payable at Lucknow.)
Last date of Seeking Clarification	<b>23.09.2019</b>
Pre-bid Meeting	<b>23.09.2019 @ 1500 Hrs</b>
Last date of issuing Reply to Pre-bid Queries & issue of addendum (if any)	<b>01.10.2019 04.10.2019</b>
Date & time of Submission of Tender	<b>11.10.2019 15.10.2019 upto 15:00 Hrs</b>
Date & time of opening of Tender	<b>11.10.2019 15.10.2019 at 15:30 Hrs</b>
Authority and place for purchase of tender documents, seeking clarifications and submission of completed tender documents	<b>Chief Engineer/ Contract,</b> Lucknow Metro Rail Corporation Ltd., Administrative Building, Vipin Khand, Gomti Nagar, Near Dr. Bhimrao Ambedkar Samajik Parivartan Sthal, Lucknow-226010, Uttar Pradesh, India <b>Email: cecontractlmrc@gmail.com</b>

**1.1.3 QUALIFICATION CRITERIA:**

**1.1.3.1 Eligible Applicants:**

- i. The tenders for this contract will be considered only from those tenderers (proprietorship firms, partnerships firms, companies, corporations) who meet requisite eligibility criteria prescribed in the sub-clauses of clause 1.1.3 of NIT. **Joint Ventures and consortiums are not allowed to participate in the tender.**







# LUCKNOW METRO RAIL CORPORATION LIMITED

Administrative building, Vipin Khand, Gomti Nagar, Lucknow - 226010

E-mail id- [cecontractlmrc@gmail.com](mailto:cecontractlmrc@gmail.com)

No. LMRC/CE-Contract/KNPCC-03/2019-20

Date: 04.10.2019

To,  
All Bidders,

**Subject:** - Addendum-02 for tender KNPCC-03.

**Ref:** - **Tender KNPCC-03:** Civil, PEB and E&M works for construction of depot cum workshop, including structural, architectural, plumbing, drainage, external development, road works, electrical, mechanical, VAC, firefighting, fire detection etc. at Polytechnic College Depot for IIT Kanpur to Naubasta Corridor-1 of Kanpur Metro.

Dear Sir,

Please find enclosed herewith the Addendum-02 to the tender KNPCC-03. Further, the tender submission/Opening dates remain as per addendum - 01.

<b><u>Summary of Addendum-02</u></b>		
1	Annexure-1	Technical specification for PEB Works.

**Enclosure: As Above**



(Deepak Gupta)  
Chief Engineer/Contract



## Addendum-02 :- Annexure-1

# Technical Specifications for PEB Works

### TABLE OF CONTENT

<b>1. GENERAL SPECIFICATIONS</b> .....	4
1.1 Description of Work Site.....	4
1.2 SCOPE OF WORK.....	4
1.3 INTERFACES.....	5
1.4 ASSOCIATED WORKS .....	5
1.5 DESIGN CRITERIA .....	5
1.6 STANDARD CODES OF PRACTICE.....	6
1.7 CONSTRUCTION DEPOT .....	7
1.8 DIMENSIONS.....	7
<b>2. STEEL STRUCTURES</b> .....	8
2.1 GENERAL.....	8
2.2 MATERIALS .....	13
2.3 HANDLING AND STORAGE .....	15
2.4 FABRICATION.....	15
2.5 WELDING .....	16
2.6 INSPECTION OF WELDS .....	20
2.7 FABRICATION TOLERANCES.....	21
2.8 INSPECTION .....	23
2.9 ERECTION.....	26
2.10 QUALITY CONTROL & TESTING REQUIREMENTS .....	27
2.11 PAINTING OF STRUCTURAL STEEL WORK .....	30
2.12 Repair of Paint Defects:.....	35
2.13 Inspection :.....	35
2.14 MEASUREMENT .....	35
<b>3. PRE-COATED STEEL SHEETING FOR ROOFS AND WALLS</b> .....	38
3.1 SCOPE OF WORK.....	38
3.2 RAIN WATER GUTTER .....	40
3.3 SPECIFICATION FOR LOUVERS:.....	40
3.4 MEASUREMENT .....	41
<b>4. POLYCARBONATE SHEETS FOR ROOF LIGHTING</b> .....	42
4.1 GENERAL.....	42
4.2 MATERIAL .....	42
4.3 SUBMITTAL.....	43

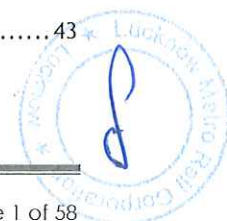



Tender KNPCC-03: Civil, PEB and E&M works for construction of depot cum workshop, including structural, architectural, plumbing, drainage, external development, road works, electrical, mechanical, VAC, fire fighting, fire detection etc. at Govt. Polytechnic Depot for IIT Kanpur to Naubasta Corridor-I of Kanpur Metro.

4.4	INSTALLATION.....	43
4.5	MEASUREMENT .....	43
<b>5.</b>	<b>POLYCARBONATE SHEETS FOR NORTH LIGHTS AND WINDOWS .....</b>	<b>45</b>
5.1	GENERAL : .....	45
5.2	MATERIAL : .....	45
5.3	SUBMITTAL : .....	45
5.4	MEASUREMENT : .....	46
5.5	APPROVED MANUFACTURURES/SUPPLIERS : .....	46
5.6	List of Approved Manufacturers/ Suppliers.....	46
<b>6.</b>	<b>TURBO VENTILATORS .....</b>	<b>47</b>
6.1	General .....	47
6.2	Scope .....	47
ANNEXURE- A .....		49
ANNEXURE- B Approved Manufacturers/ Supplier.....		50
ANNEXURE- C - (Design Base Report) .....		53









## 1. GENERAL SPECIFICATIONS

### 1.1 Description of Work Site

The project site is located at Kanpur (Uttar Pradesh). The location of the work and the general site particulars are shown in the General Arrangement Drawings enclosed in the tender drawings.

The Depot & Workshop covered by this work is located at Govt. Polytechnic, Kanpur for Corridor-1 of Kanpur Metro.

### 1.2 SCOPE OF WORK

#### 1.2.1 General

The work content in this contract consists of:

- i. Design, Fabrication, Supply and erection of PEB buildings for Workshop, Inspection bay, Stabling Sheds, Interior cleaning, Shed for RGM, Pit Wheel Lathe & Watch towers including Gantry girders wherever required.
- ii. Design, fabricating and erection of hot dipped galvanized Rain Water Gutters
- iii. Providing and fixing pre coated galvalume sheets in single and double layer for roofing and side cladding. Double layer must be factory insulated by 30 mm thick rigid poly urethane foam (PUF) material.
- iv. Providing and fixing 3 mm thick Polycarbonate sheets
- v. Design, fabrication, supply and erection of structural steel for roof inspection platforms
- vi. Providing structural steel for rail track support columns and car parking sheds
- vii. Supply, installations & testing of supporting structures of EOT cranes.

The work is to be constructed and maintained as per relevant IS Codes, relevant International Standards, CPWD Specifications, Particular Specifications, and Tender Drawings and or as directed by the Engineer.

#### TECHNICAL REQUIREMENTS:

Tenderers must have their own Fabrication unit with fully computerized and automatic machineries for cutting, bending, drilling, moulding, welding, grinding etc. with flagged facilities of sand blasting, painting and testing equipments complete.

The following requirements are to be followed by the Contractor:

- a. All aspects of quality assurance, including procurement & testing of materials and other components of the work, as specified or as directed;
- b. Clearing of site and handing over of all the Works, as directed;
- c. Maintenance of the completed Work during the maintenance period.





- d. Submission of Design drawings, Erection drawings, Fabrication drawings, Completion drawings (As built drawings) Calculations, Analysis and other related documents as specified.
- e. Any other requirement to commission the Depot & Workshop at Govt. Polytechnic for Kanpur Metro Project in all respects in accordance with the provisions of the Contract and/or to ensure the structural stability and safety during and after construction.

### 1.3 INTERFACES

The Scope of Work for the interfaces work for various interfacing Contracts. In brief, the interfaces include but are not limited to:

- a. Supply of anchor bolts to civil contractor.
- b. Interfacing with OHE contractor.
- c. Interfacing with E&M contractor.
- d. Interfacing with Track contractor.

### 1.4 ASSOCIATED WORKS

Works to be performed shall also include:

- a. All general works preparatory to the PEB buildings, OHE arrangements and EOT cranes arrangements of Depot & Workshop at Govt. Polytechnic, Kanpur for Kanpur Metro project.
- b. Works of any kind necessary for the due and satisfactory construction, completion and maintenance of the works to the intent and meaning of the drawings adopted, technical specifications, to best Engineering standards and orders that may be issued by the Engineer from time to time, compliance by the agency with all Conditions of Contract,
- c. Supply of all materials, apparatus, plants, equipment, tools, fuel, water, strutting, timbering, transport, offices, stores, workshop, staff, labour and the provision of proper and sufficient protective works, diversion, temporary fencing, lighting and watching required for the safety of the public and protection of works on adjoining land;
- d. First-aid equipment, sanitary accommodation for the staff and workmen, effecting and maintenance of all insurances,
- e. The payment of all wages, salaries, provident funds, fees, royalties, duties or other charges arising out of erection of works and regular clearance of rubbish, clearing up, leaving the site perfect and tidy on completion.

### 1.5 DESIGN CRITERIA

The Design of temporary works covers all the items pertaining to:

- a. Form work, casting and stacking yard, staging, launching Scheme and/or transportation scheme.
- b. Drawings furnished with the Tender Documents show the level of works based on available soil investigation data. These may require change at the time of actual execution of works.





## 1.6 STANDARD CODES OF PRACTICE

### 1.6.1 Availability

The contractor shall provide at site all relevant Codes of practice, and CPWD Specifications.

#### Legend

ASCE	American Society of Civil Engineers
AISC	American Institute of steel construction
AISI	American Iron & Steel Institute
AWS	American Welding Society
ASME	American Society of Mechanical Engineers
ASTM	American Society for Testing Materials
MBMA	Metal Building manufacturers Association
BS	British Standard
CPWD	Central Public Works Department
DIN	Deutsche Institute for Normunge.V.
IRC	Indian Road Congress
IRS	Indian Railway Standards
IS	Indian Standards
JIS	Japanese Industrial Standard
MOST	Ministry of Surface Transport
MORTH	Ministry of Road Transport and Highways

### 1.6.2 Order of Precedence

Wherever Indian Standards do not cover some particular aspects of design/construction, relevant British/European/American Standards will be referred to.

In case of discrepancy among Standard codes of practice, CPWD Specifications, General and particular Specifications, and Bill of Quantities, the order of precedence will be as below:

- a. Bill of Quantities
- b. Particular Specifications
- c. General Specifications
- d. CPWD Specifications.
- e. Standard Codes of Practice.

In case of discrepancy among Standard Codes of Practice, the decision of Engineer will be final and binding.

### 1.6.3 Applicable Codes

The summarized list of codes applicable to structural and architectural works. This will not preclude the Engineers right to refer to any other code applicable for the satisfactory execution of the work.





## 1.7 CONSTRUCTION DEPOT

The land required for this work will be provided within the land acquired by the Employer at Govt. Polytechnic Depot - Kanpur & workshop. The contractors can utilize from within this land for construction of site office and construction depot, as approved by the Engineer.

## 1.8 DIMENSIONS

1. Figured dimensions on drawings shall only be followed and drawings to a large scale shall take precedence over smaller scale drawings. All dimensions shall be checked on site prior to execution.

The dimensions where stated do not allow for waste, laps, joints, etc. but the Contractor shall provide at his own cost sufficient labour and materials to cover such waste, laps, joints, etc.

2. The levels, measurements and other information concerning the existing site as shown on the drawings are believed to be correct, but the Contractor should verify them for himself and also examine the nature of the ground as no claim or allowance whatsoever will be entertained on account of any errors or omissions in the levels or the description of the ground levels or starts turning out different from what was expected or shown on the drawings.

TABLE OF INTERFACE (1)

<i>WORK DESCRIPTION</i>	<b>SCOPE OF CIVIL CONTRACTOR</b>	<b>SCOPE OF TRACK CONTRACTOR WORK</b>
Installation of Track in Workshop (Inspection Bay), Stabling Shed, Interior Cleaning and shed for RGM.	Erection of PEB structures and supply of rail track support columns.	Supply of detailed interface drawings and Install track on the columns.

TABLE OF INTERFACE (2)

<i>WORK DESCRIPTION</i>	<b>SCOPE OF PEB CONTRACTOR</b>	<b>SCOPE OF OHE (TRACTION) CONTRACTOR</b>
Installation of OHE in (Inspection Bay), Stabling Shed, Interior Cleaning Building  The overall weight to be taken into account is 500 kg / as per Load criteria at each suspension and (As per Traction Contractor requirements)	Providing the supporting structure preparation for OHE suspension/bracket assemblies on the columns and drop arms fixed to the PEB structure as per specification in detailed interfacing drawing.	Supply of detailed interface drawings including requirements of mounting plates on columns, drop arms fixed to the trusses, supports for termination arrangements on beams/slabs/Rafters etc. for various buildings  Supply and install bracket assemblies with fastening devices on the columns and drop arms.





## 2. STEEL STRUCTURES

### 2.1 GENERAL

- This section covers the general requirements of designing, preparing necessary drawings, and, providing, fabricating, painting, transporting, erecting, fixing in position structural steel work for buildings, including all necessary temporary works and conducting of associated tests.
- Contractor shall ensure that the Technical specifications detailed herein are carefully read and understood in conjunction with, and related to bill of quantities, and, the contractor in his rates includes all requirements defined herein and in other parts of the Contract Document.
- Applicable Codes and Standards

The codes and standards generally applicable to the work of this section are listed below. These are in addition to all relevant Indian Standard Codes as specified in the referenced documents. Latest revisions of the codes shall only be applicable.

IS: 102	Ready mixed paint, brushing, red lead non-setting, priming
IS: 104	Ready mixed paint, brushing, zinc-chrome, priming
IS: 210	Gray Iron Castings
IS: 451	Technical Supply Conditions for Wood Screws
IS: 800	Code of Practice for General Construction in Steel
IS: 801	Code of Practice for use of Cold Formed Light Gauge Steel Structural Members in General Building Construction.
IS: 806	Code of Practice for use of Steel Tubes in General Building Construction
IS: 808	Dimensions of Hot Rolled Steel beam, channel and angle sections
IS: 811	Cold Formed Light Gauge Structural Steel Sections
IS: 813	Scheme of Symbols for Welding
IS: 814	Covered Electrodes for Manual Metal Arc Welding of Carbon and Carbon-Manganese Steel
IS: 816	Code of Practice for use of Metal Arc Welding for General Construction in Mild Steel
IS: 818	Code of Practice for Safety and Health requirements in electric and Gas Welding and Cutting Operations
IS: 822	Code of Procedure for Inspection of Welds





IS: 875	Code of Practice for Structural Safety of Building, Loading Standards.
IS: 1024	Code of Practice for use of Welding in Bridges and Structures Subject to Dynamic Loading
IS: 1030	Carbon Steel Castings for General Engineering Purposes
IS: 1120	Coach Screws
IS: 1161	Steel Tubes for Structural Purposes
IS: 1182	Recommended Practice for Radiographic Examination of Fusion Welded Butt Joints in Steel Plates
IS: 1363	Hexagon Head Bolts, Screws and Nuts (Grade-C)
IS: 1364	Hexagon Head Bolts, Screws and Nuts (Grades A & B)
IS: 1365	Slotted Counter-sunk Head Screws
IS: 1367	Technical Supply Condition for Threaded Fasteners
IS: 1852	Rolling and Cutting Tolerances for Hot Rolled Steel Products
IS: 1977	Low Tensile Structural Steel
IS: 2016	Plain Washers
IS: 2062	Steel for General Structural Purposes
IS: 2074	Ready Mixed Paint, Air drying, Red Oxide-Zinc Chrome Priming
IS: 3063	Fasteners- Single Coil Rectangular Section Spring Washers
IS: 3400	Methods of Test for Vulcanized Rubber
IS: 3443	Crane Rail Sections
IS: 3600	Testing Methods of Fusion Welded Joints and Weld Metal in Steel
IS: 3613	Acceptance Tests for Wire Flux combination for submerged, welding
IS: 3757	High Strength Structural Bolts
IS: 4000	Code of Practice for High Strength Bolts in Steel Structures
IS: 4923	Hollow Steel Sections for Structural Use
IS: 5369	General Requirements for Plain Washers and Lock Washers
IS: 5624	Foundation Bolts
IS: 6227	Code of Practice for use of Metal Arc Welding in Tubular Structures
IS: 6623	High Strength Structural Nuts
IS: 6639	Hexagonal bolts for steel structures.





IS: 8500 Structural Steel Micro-alloyed (Medium and High strength Qualities)

IRC : 83 (Part-II) : Elastomeric Bearings

#### 2.1.1 DESIGN

- The contractor will be required to carry out detailed design of the structures, prepare engineering drawings and detailed 'shop drawings', get these approved from Engineer, and then carry out the fabrication work based on approved drawings.
- Contractor's designs shall, unless otherwise specified, be based on provisions of relevant BIS codes. Design guideline and design parameters are mentioned in ANNEXURE – C to these specifications.

Where corresponding parameters mentioned in BIS codes are different from those mentioned in ANNEXURE-C, the latter shall take precedence.

- Contractor's designs shall be based on general descriptions of buildings given in ANNEXURE – D to these specifications, and those shown in Tender Drawings.

Where information given in ANNEXURE-D do not tally with the Tender Drawings, information given in Tender drawings shall take precedence.

- Where codes and standards listed in clause 1.6.1 & 2.1 do not cover the requirements of design, only in those cases the contractor may refer to other International Standards of design. However, such references should be made only with the approval of the Engineer.
- Contractor shall submit his design calculations and 'Engineering Drawings' to the Engineer for his approval. The contractor is advised to discuss his design philosophy and design procedure with the Engineer before proceeding with the final design work.
- It shall be the responsibility of the contractor to obtain all relevant design information from the Engineer for preparing his designs, including all special loading like loads from cranes and other utility services supported by the structure.

#### 2.1.2 DRAWINGS

- 'Tender Drawings' shall be the 'Basic' drawings for developing design drawings. Design drawings shall then be developed in to final 'Shop Drawings' to be prepared by the contractor. For preparing shop drawings, the contractor shall obtain written approval from the Engineer.
- Tender drawings furnished to the Contractor shall form a part of these specifications. The Contractor shall consult these in detail for all the information contained therein, which pertains to and is required for his work.





- Revisions to drawings, even after release for preparation of shop drawings, are likely to be made to reflect additional data, or, additional details defining updated requirements. Revisions to drawings and any new drawings made to include additional work for the Contractor shall be considered a part of this specification and contract. Extra claims by the contractor on this account shall not be entertained.
- Tender drawings show all relevant dimensions, and if necessary, clearances of structures, special loading where necessary, general location of openings at various levels and all other information required to enable the Contractor to prepare drawings for general engineering / fabrication and erection.
- It shall be clearly understood that the Tender drawings are only informative drawings and are not intended to show exact and final information or specific connection details.
- In case of variations in 'Drawings' and 'Specifications', the decision of the Engineer shall be final and binding. Should the Contractor during the execution of his work, find discrepancies in the information furnished to him, he shall refer such discrepancies to the Engineer before proceeding with such work.
- Contractor shall prepare all fabrication and erection drawings necessary for completing the work satisfactorily.
- Drawings shall be of one standard size, and shall be clear and legible. Drawings shall be based on Tender drawings supplied to the contractor, but he shall verify actual clearances and dimensions from site on works executed by other agencies and from Engineer
- Shop drawings shall include, but not be limited to:-
  - (a) Detailed marking plans.
  - (b) Details of member connections and connections to other structures/ components of buildings.
  - (c) Detailed dimensions for fabrication indicating dimensional modifications required for field conditions.
  - (d) Welding and bolting procedures to be used both at shop and field.
  - (e) Cambers required to be provided, and permissible tolerances in fabrication.
  - (f) Assembly and erection sequences indicating components to be connected at field.
  - (g) Complete bill of materials for each component (preferably drawing wise).
- Before submitting of shop drawings and calculations to the Engineer for his approval, these shall be checked and certified by the contractors own structural engineer. Till such time shop





details of a component are approved by the CM, fabrication work for the component shall not be started.

- If necessary and called for by the Engineer, shop drawings shall be revised to suit modified requirements as mentioned in clause 2.1.2, and these shall be resubmitted for approval of the Engineer.
- While the shop drawings prepared by the contractor, and approved by the Engineer represent the correct interpretation of work to be done, the contractor is not relieved of his responsibilities for:-
  - (a) Dimensional accuracy
  - (b) Correctness of engineering and design of connections
  - (c) Fit of parts
  - (d) Details
  - (e) Errors or omissions
  - (f) Material and workmanship
  - (g) Methodology of fabrication and erection
  - (h) Safety of performance

### 2.1.3 SUBMITTALS

- On commencement of the Project, the Contractor shall submit the following to the Engineer :-
  - A. Prior to the technical submittals, the contractor shall submit detailed baseline program and methodology indicating the proposed overall schedule for documentation such as calculations, shop/ working drawings, plan/ procedures and records. Submission of samples, process of fabrication / delivery to site storage yard for the approval of the Engineer.
  - B. Complete fabrication drawings, materials lists, cutting lists, bolt lists, welding schedules and QC schedules, based on the design drawing furnished to him and in accordance with the approved schedule. It is highlighted that structural steel members, dimensions thereof indicated in tender drawings are tentative only, and may be modified during final design stage.
  - C. Results of any tests, as and when conducted and as required by the Engineer.
  - D. Manufacturer's mill test reports in respect of steel materials, bolts, nuts and electrodes, wires as may be applicable.
  - E. A detailed list of all constructional Plant & Equipment, such as cranes, derricks, winches, welding sets etc. their makes, model, present condition and location, available to the contractor and the ones he will employ on the job to maintain the progress of work in accordance with the contract.





- F. The total number of experienced personnel of each category, like fitters, welders, riggers etc., which he intends to deploy on the project.
- G. The contractor shall submit complete design calculations for any alternative sections proposed by him, for approval of the Engineer. Use of any alternative section shall be subject to approval of the Engineer. However, no extra payment will be entertained on account of this except as specified in BOQ.

## 2.2 MATERIALS

### 2.2.1 STRUCTURAL STEEL

- (a) All Structural components other than purlins & side cladding runners shall be made from Hot Rolled sections and plates with Grade – B having a minimum yield stress of 250 Mpa (Grade FE 410 WB) conforming to IS:2062. Minimum metal thickness for Hot Rolled shall be 6mm. such steel shall be procured from approved manufacturers.
- (b) Whenever high strength steel is specified, it shall be conforming to IS: 8500.
- (c) All steel tubes shall be hot finished seamless steel tubes (HFG) of the specified strength and as approved by the Engineer, and shall conform to IS: 1161. Tubes made by other processes and which have been subjected to cold working, shall be regarded as hot finished if they have subsequently been heat treated and are supplied in the normalized condition.
- (d) Purlins and side cladding runners only shall be made from cold formed sections and shall conform to ASTM A570 Gr 50 with minimum yield strength of 345 Mpa. Minimum metal thickness for cold formed sections shall be 3mm UNLESS SPECIFICALLY PERMITTED BY Engineer-in-charge/Structural Consultants.

#### 2.2.1.1 STEEL SUPPLIED BY THE CONTRACTOR

- The Contractor shall furnish to the Engineer all mill orders covering the material ordered by him for this project and also the test reports received from the Mills for his approval and information. It is not intended that all the steel materials to be supplied by the Contractor for the work shall be specially purchased from the rolling mills. The Contractor's stock material may be used, provided the mill test reports identified with the materials, satisfactorily demonstrate the specified grade and quality. The Engineer shall have the right to test random samples to prove authenticity of the test certificates produced by the Contractor, at the Contractor's cost.





- All steel materials supplied by the Contractor shall be in a sound condition, of recent manufacture, free from defects, loose mill scale, slag intrusions, laminations, pitting, flaky rust, etc. and be of full weight and thickness specified.
- Wherever the Contractor, in order to accommodate his other materials in stock, desires to substitute structural steels or plates for the sizes shown on drawings, such substitutions shall be made only after authorization in writing by the Engineer.
- The Engineer may direct that substitution be made, when he considers such substitutions is necessary.

#### 2.2.2 THREADED FASTENERS

- Technical supply conditions for bolts and nuts shall comply with IS: 1367. Bolts and nuts shall be of property class 4.6 (Grade B) of IS: 1367 and shall conform to IS: 5624. Unless specified otherwise, the bolts and nuts shall be hexagonal and shall conform to Property Class compatible with the property class of the bolt used.
- All anchor bolts and nuts shall be of property class 4.6 (Grade-B) of IS: 1367, and shall conform to IS: 5624. All nuts shall be hexagonal, and shall conform to property class compatible with the property class of the bolt used.
- Plain washers shall conform to IS: 5369, unless otherwise specified. One washer shall be supplied with each bolt and, in case of special types of bolts, more than one washer as needed for the purpose shall be supplied. An additional double coil helical spring washer, conforming to IS: 6755, shall be provided for bolts carrying dynamic or fluctuating loads and those in direct tension.

#### 2.2.3 ELECTRODES

- Electrodes used for metal arc welding of mild steel shall be heavy coated type electrodes conforming to IS : 814 (Part I & II) and shall be of the best quality approved by the Engineer. All electrodes/ wires / flux shall be kept under dry conditions. Any electrode / wires /flux damaged by moisture shall not be used unless it is guaranteed by the manufacturer that, when it is properly dried, there will be no detrimental effect. Any electrode, which has part of its flux coating broken away or is otherwise damaged, shall be rejected. Any electrode /wires/ flux older than six (6) months from the date of manufacture shall not be used. Batch certificates for electrodes/ wires /flux shall be submitted by the Contractor. Welding consumables for Manual metal arc welding shall conform to IRS-M-28, Wire and Flux combination for Submerged Arc welding to IRS-M-39 and filler wires for CO2 welding to RDSO/ M & C Specifications.





## 2.3 HANDLING AND STORAGE

- Proper storage of steel (sections and fabricated members) at the job site shall be the responsibility of the Contractor.
- Structural steel shall be stored out of mud and dirt. Proper drainage of the storage area shall be provided. These shall be protected from damage or soiling by adjacent construction operations.
- Fabricated steel shall not be handled until the paint has thoroughly dried. Care shall be taken to avoid paint abrasions and other damage. Steel work shall be transported in such a way so as not to over stress the fabricated sections. All pieces bent or otherwise damaged shall be rejected and shall be replaced by the contractor at his own cost.
- Checking and inspection of fabricated structural steel work by the Engineer shall be done at various stages of completion of fabrication work. The contractor is required to ensure that fabricated steel work is properly stacked such that all joints of all members are either visible or accessible for inspection at all stages of inspection work. Care should also be taken to ensure that fabricated members are not subjected to stresses due to defective stacking.

## 2.4 FABRICATION

- All fabrication work shall be done in accordance with IS:800 2007, read in conjunction with relevant codes mentioned therein.
- Fabrication shall be done in workshops approved by Engineer, unless specifically permitted by Engineer that fabrication can be done at site. Under such circumstances work shall be done on a specially designed and constructed platform. Location, size, specification and construction of such a platform shall have prior approval of Engineer. Loads associated with such platforms shall be provided to Engineer.
- Mild steel rolled sections and plates shall be cut by shearing/machining and grinding the surfaces to true sizes and shapes. Gas cutting of mild steel may be permitted by the Engineer, provided that every cut face and edge is smoothed by grinding operation. Prior approval of Engineer must be obtained for using gas-cutting techniques either by mechanized gas cutters or manually operated gas cutters. While, using gas-cutting methods, proper allowance must be made for grinding to bring the cut piece to exact required dimensions.
- Extensive use of templates shall be made in doing fabrication work. Templates shall be clean and should have true surfaces prepared for every successive use. Reinforcements for the structural steel members if required shall be included. In case actual members are used as templates for similar pieces, it will be at the discretion of the Engineer to decide whether such





pieces are fit to be incorporated in the finished structure. Jigs and manipulators shall be used, where practicable, and shall be designed to facilitate welding and to ensure that all welds are easily accessible to the operators.

- All material shall be straight and free from twist and bends unless required to be curvilinear in form. If necessary the material shall be straightened and / or flattened / straightened by pressure. Heating of rolled sections and plates for purpose of straightening shall not be permitted.
- Curvilinear members shall be formed by bending with the help of pneumatic press. Final shaping, to a very limited extent, however, may be done by local heat application. This shall be done only on receiving approval from the Engineer.

- **HOLING**

All holes shall be made at right angles to the surface of the member. Holes shall be clean cut without any torn or jagged edges. Holes shall be done by drilling. Punching shall not be resorted to, unless previously approved by the Engineer. In any case, punching of holes in materials having a thickness in excess of the connector diameter, or, for materials thicker than 16 mm, the hole shall be punched 3 mm less in diameter than the required size and then reamed to the full size. Holes shall not be formed or enlarged by burning or gas cutting under any circumstances.

## 2.5 WELDING

- **GENERAL**

In general only Automatic submerged arc welding will be used for fabrication. Subject to approval of Engineer, Metal inert gas welding may be done for short length where access to the location of the weld does not permit submerged arc welding. The welding and the welded work shall conform to IS: 816, unless otherwise specified. As much work as possible shall be welded in shops and the layout and sequence of operations shall be so arranged as to eliminate distortion and shrinkage stresses. Unless otherwise specified all weld shall be for full contact for all sides.

- Electrodes for shielded-arc manual welds shall comply with the requirements of IS:814 and shall be amenable to radiographic tests and shall be of approved make. The electrodes for manual arc welding shall be suitable for use in the position and type of work, as laid down in the above specifications and as recommended by the manufacturers. Electrodes classification group 1 or 2 as given in IS: 814 shall be used for welding steel conforming to IS: 2062. Electrodes shall conform to IS-1442 for steel conforming to IS : 8500. Joints in materials above 20 mm thick, and, all important connections shall be made with low hydrogen electrodes Electrode flux covering shall be sound and





unbroken. Broken or damaged coating shall cause the electrodes to be discarded. Covered electrodes for manual arc-welding shall be properly stored in an oven prior to use in a manner recommended by the Manufacturer and only an hour's quota shall be issued to each welder from the oven.

- Electrodes larger than 5 mm diameter shall not be used for root-runs in butt-weld.
- Welding plant and accessories shall have capacity adequate for the welding procedure laid down and shall satisfy appropriate standards and be of approved make and quality, the Contractor shall maintain all welding plant in good working order. All the electrical plant in connection with the welding operation shall be properly and adequately earthed and adequate means of measuring the current shall be provided.
- All welds shall be made only by welders and welding operators who have been properly trained and previously qualified by tests to perform the type of work required as prescribed in the relevant applicable standards.
- All welds shall be free from defects like blow holes, slag inclusions, lack of penetration, undercutting, cracks etc. All welds shall be cleaned of slag or flux and show uniform sections, smoothness of weld metal, feather edges without overlap and freedom from porosity.
- Fusion faces and surfaces adjacent to the joint for a distance of at least 50 mm on either side shall be absolutely free from grease, paint, loose scales, moisture or any other substance which might interfere with welding or adversely affect the quality of the weld. Joint surfaces shall be smooth, uniform and free from fins, tears, laminations etc. Preparation of fusion faces shall be done in accordance with the approved fabrication drawings by shearing, chipping, machining or machine flame cutting except that shearing shall not be used for thickness over 8 mm.
- In the fabrication of cover-plated beams and built up members all shop splices in each component part shall be made before such component part is welded to other parts of the member. Wherever weld re-inforcement interferes with proper fit-up between components to be assembled for welding, these welds shall be ground flush prior to assembly.
- Members to be joined by fillet welding shall be brought and held as close together as possible and in no event shall be separated by more than 3 mm. If the separation is 1.5 mm or greater, the fillet weld size shall be increased by the amount of separation. This shall only apply in the case of continuous welds. The fit-up of joints at contact surfaces which are not completely sealed by welds shall be close enough to exclude water after painting.
- The separation between fraying surfaces of lap joints and butt joints with backing plate shall not exceed 1.5 mm. Abutting parts to be butt welded shall be carefully aligned and the correct root gap maintained throughout the welding operation. Misalignments greater than 25 percent of the





thickness of the thinner plate or 3 mm whichever is smaller shall be corrected and in making the correction the parts shall not be drawn into a slope sharper than 2 degrees (1 in 27.5).

- Welding procedures recommended by appropriate welding standards and known to provide satisfactory welds shall be followed. A welding procedure shall be prepared by the Contractor and submitted to the Engineer for approval before start of welding.
- Approval of the welding procedure by the Engineer shall not relieve the Contractor of his responsibility for correct and sound welding without undue distortion in the finished structure.
- Voltage and current (and polarity if direct current is used) shall be set according to the recommendations of the Manufacturer of the electrode being used, and suitable to thickness of material, joint form etc. The work shall be positioned for flat welding wherever practicable and overhead weld shall be avoided.
- No welding shall be done when the surface of the members is wet, nor during periods of high wind unless the welding operator and the work are properly protected. In joints connected by fillet welds, the minimum sizes of single run fillet welds or first runs and minimum full sizes of fillet welds shall conform to the requirements of IS: 816 and IS: 823. Fillet welds larger than 8 mm shall be made with two or more passes.
- All 'full penetration butt welds' made by manual arc-welding, except when produced with the aid of backing material or welded in flat position, from both sides in square-edge material, not over 8 mm thick with root opening not less than one-half the thickness of the thinner part joined, shall have the root of the initial layer gouged out on the back side before welding is started from that side, and shall be so welded as to secure sound metal and complete fusion throughout the entire cross section.
- Butt welds shall be terminated at the ends of a joint in a manner that will ensure their soundness. Where abutting parts are 20 mm or more in thickness, run-on and run-off plates with similar edge preparation end having a width not less than the thickness of the thicker part joined shall be used. These extension pieces shall be removed upon completion of the weld and the ends of the weld made smooth and flush with the abutting parts. Where the abutting parts are thinner than 20 mm the extension pieces may be omitted but the ends of the butt welds shall then be chipped or gouged out to sound metal and side welded to fill up the ends to the required reinforcement.
- Each layer of a multiple layer weld except root and surface runs may be moderately peeled with light blows from a blunt tool. Care shall be exercised to prevent scaling or flaking of weld and base metal from over-peeling.
- Before commencing fabrication of a member or structure in which welding is likely to result in distortion and/or locked up stresses, a complete programme of fabrication, assembly and welding





shall be made and submitted to the Engineer for his approval. Such a programme shall, include, besides other appropriate details, full particulars in regard to the following :-

- i) Proposed pre-bending of components such as flanges and presetting of joints to offset expected distortion.
- (ii) Make up of sub-assemblies proposed to be welded before incorporation in final assembly.
- (iii) Proposed joint forms, classification of wire and flux or covered electrodes, welding process including fitting and welding sequence with directions in which freedom of movement is to be allowed.
- (iv) Proposed number, spacing and type of strong details of jigs and fixtures for maintaining proper fit up and alignment during welding.
- (v) Any other special features like assembling similar members back to back or stress relief.

**Suggestive Minimum Preheating Of Metals:**

Thickness Of Thickest Part At Point Of Welding	Minimum Preheat&InterpassTemperature			
	Other than low-hydrogen welding electrodes		LowHydrogenwelding electrodes	
	IS : 226 steel or IS : 2062 steel	IS : 961 steel	IS : 226 steel or IS : 2062 steel	IS : 961 steel
Upto 20 mm incl.	None	Welding with this process not allowed	None	10°C
Over 20 mm to 40 mm incl.	65°C		10°C	65°C
Over 40 mm to 63 mm incl.	110°C		95°C	110°C
Over 63 mm	150°C		110°C	150°C

Minimum preheat temperature for metal thickness up to 50 mm shall be 10°C.





- If so desired by the Engineer, mock up welding shall be carried out at the Contractor's cost to establish the efficacy of the proposed programme, with any modification suggested by the Engineer in limiting distortion or/and residual stress to acceptable levels. Such modifications will not relieve the Contractor of any of his responsibilities.
- The ends of butt joints shall be welded so as to provide full throat thickness. This may be done by the use of extension pieces, cross-runs or other approved means. The weld face shall, at all places, be deposited projecting the surface of the parent metal. Where a flush surface is required, the surplus metal shall be dressed off. Splices and butt joints of compression members, depending on contact for stress-transmission, shall be accurately machined over the whole section. In column bases, the ends of shafts together with the attached gussets, angles, Channels etc., after bolting and/or welding together as the case may be, shall be accurately machined so that the parts connected butt over the entire surface of contact.. Care shall be taken that connecting angles or channels are fixed with such accuracy that they are not reduced in thickness by machining by more than 0.8mm.
- The minimum leg length of a fillet weld as deposited shall be not less than the specified size. In no case shall a concave weld be deposited, unless specifically permitted. Where permitted, the leg length shall be increased above that specified length, so that the resultant throat thickness is as great as would have been obtained by the deposition of a flat-faced weld of the specified leg length.
- After making each run of welding, all slag shall be thoroughly removed and the surface cleaned. The weld metal, as deposited (including tack welds), shall be free from-cracks, slag inclusions, porosity, cavities and other deposition faults. The weld metal shall be properly fused with the parent metal without under cutting or overlapping at the toes of the weld. The surface of the weld shall have a uniform consistent contour and regular appearance.

## 2.6 INSPECTION OF WELDS

- 2.6.1 All welds shall be inspected for flaws by any of the methods described in these specifications, and as per IS: 822. The choice of the method to be adopted shall be determined by the Engineer.
- 2.6.2 The Contractor shall arrange for all tests as called for in the schedule of quantities, at his own cost.
- 2.6.3 In case the tests uncover defective work, such tests shall be at the Contractor's cost and the Contractor shall correct such defects at his own cost, and prove the soundness of rectified work.
- 2.6.4 The correction of defective welds shall be carried out as directed by the Engineer without damaging the parent metal. When a crack in the weld is removed, magnetic particle inspection or any other equally positive means as prescribed by the Engineer shall be used to ensure that the whole of the crack and material up to 25 mm beyond each end of the crack has been removed. Cost of all such tests and operations incidental to correction shall be to the Contractor's account.





## 2.7 FABRICATION TOLERANCES

Unless otherwise shown on drawings, the fabrication tolerances shall generally be as detailed hereunder.

### 2.7.1 STRAIGHTNESS

The dimensional and weight tolerance for rolled shapes shall be in accordance with IS:1852 for indigenous steel and equivalent applicable codes for imported steel. The acceptable limits for straightness (sweep and camber) for rolled or fabricated members shall be: Struts and columns: L/1000 or 10 mm whichever is smaller.

For all other members not primarily in compression such as purlins, beams, bracings & web members of trusses and latticed girders: L/500 or 15 mm whichever is smaller. Where L is the length of finished member, or such lesser length as the Engineer may specify.

### 2.7.2 TWISTS

- A limit for twist (prior to erection) in :-

Box girders and heavy columns: L/1500

Other members: L/1000

The twist of the member between any two sections shall be measured with the web vertical at one of the sections.

### 2.7.3 CAMBER

Tolerance in specified camber of structural members shall be  $\pm 3$  mm.

### 2.7.4 LENGTH

Tolerance in specified length shall be as follows:-

<i>Type of Member</i>	<i>Tolerance</i>
A column finished for contact bearing:	$\pm 1$ mm
Other members (e.g. beams) under 10 m:	+ 0 and - 3 mm
Other members (e.g. beams) 10 m long and over:	+ 0 and - 5 mm

### 2.7.5 SQUARE-NESS AT END OF MEMBERS

- Beam to beam and beam to column connections where the abutting parts are to be jointed by butt welds, permissible deviation from the square-ness of the end is :-

Beams up to 600 mm in depth : 1.5 mm





Beams over 600 mm in depth : 1.5 mm every 600 mm depth

Up to a max of 3 mm

- Where abutting parts are to be jointed by bolting through cleats or end plates, the connections require closer tolerance. Permissible deviation from square ness of the end is -

Beams up to 600 mm in depth: 1 mm

Over 600 mm in depth: max of 1.5 mm.

#### 2.7.6 BUTT JOINTS

- For full bearing, two abutting ends of columns shall first be aligned to within 1 in 1000 of their combined length and then the following conditions shall be met:
  - (a) Over at least 80% of the bearing surface the clearance between the surfaces does not exceed 0.1 mm.
  - (b) Over the remainder of the surfaces the clearance between the surfaces does not exceed 0.3 mm. Where web stiffeners are designed for full bearing on either the top flange or bottom flange or both, at least half the stiffener shall be in positive contact with the flange. The remainder of the contact face could have a max. gap of 0.25 mm.

#### 2.7.7 DEPTH OF MEMBER

- Acceptable deviation from the specified overall depth is :

For depths of 900 mm and under:	+ / - 3 mm
For depths over 900 mm and under 1800 mm:	+ / - 5 mm
For Depths of 1800 mm and over:	+ 8 mm ; - 5 mm.

#### 2.7.8 WEB PLATES

Acceptable deviation from flatness in girder webs in the length between the stiffeners or in a length equal to the girder depth shall be 1/150th of the total web depth.

#### 2.7.9 FLANGE PLATES

- Limit for combined warp-age and tilt on the flanges of a built up member is 1/200 of the total width of flange or 1.5 mm whichever is smaller measured with respect to centre-line of flange.





- Lateral deviation between centre-line of web plate and centre-line of flange plate at contact surfaces, in the case of built up sections shall not exceed 3 mm.

## 2.8 INSPECTION

The Contractor shall give due notice to the Engineer in advance of the materials or workmanship getting ready for inspection.

- All rejected material shall be promptly removed from the shop and replaced with new material for the Engineer's approval / inspection. The fact that certain material has been accepted at the Contractor's shop shall not invalidate final rejection at site by the Engineer, if it fails to be in proper condition or has fabrication in-accuracies which prevent proper assembly. No material shall be painted or dispatched to site without
- Inspection and approval by the Engineer unless, such inspection is waived in writing by the Engineer.
- Shop inspection by the Engineer or his authorized representative, or, submission of test certificates and acceptance thereof by the Engineer, shall not relieve the Contractor from the responsibility of furnishing material conforming to the requirements of these specifications. Nor shall it invalidate any claim, which the Engineer may make because of defective or unsatisfactory material and/or workmanship.
- The Contractor shall provide all the testing and inspection services and facilities for shop work except where otherwise specified. For fabrication work carried out in the field, the same standard of supervision and quality control shall be maintained as in shop fabricated work. Inspection and testing shall be conducted in a manner satisfactory to the Engineer.

### 2.8.1 TESTING

#### 2.8.1.1 MATERIAL TESTING

- If mill test reports are not available for any steel materials, the same shall be got tested by the Contractor to the satisfaction of Engineer to demonstrate conformity with the relevant specification.

#### 2.8.1.2 TESTS ON WELDS

##### MAGNETIC PARTICLE TEST

Only where the Engineer requires that flaw-detection of welds be done by 'Magnetic Particle Test', in such cases the tests are to be done in accordance with IS: 3703. If heat treatment is performed, the completed weld shall be examined after the heat treatment. All defects shall be repaired and re-tested. Magnetic particle tests shall be carried out using alternating current. Direct current may be used with the explicit written permission of the Engineer.

#### 2.8.1.3 DYE PENETRATION TEST

Where welds are required to be examined by dye penetration inspection method, such tests shall be carried out in accordance with IS: 3658.





#### 2.8.1.4 RADIOGRAPHIC INSPECTION

Whether instructed by Engineer, or not, all 'Butt' welds shall be fully inspected by radiographic examination method. Such examination shall be done in accordance with the recommendations of IS: 1182.

#### 2.8.2 TEST FAILURE

- At any stage, in the event of any material or work failing to meet an inspection or test requirement, which is not overseen by the Engineer, the Contractor shall notify the Engineer immediately. The Contractor must obtain permission from the Engineer before repair is undertaken. The quality control procedures to be followed to ensure satisfactory repair shall be subject to approval by the Engineer. The Engineer has the right to specify additional inspection or testing as he deems necessary, and the additional cost of such testing shall be borne by the Contractor. The Contractor shall maintain records of all inspection and testing which shall be made available to the Engineer on demand.

#### 2.8.3 SHOP MATCHING

Some steel work, particularly columns along with tie beams, bracings etc. may have to be shop assembled to ensure satisfactory fabrication. If the Engineer so desires, he may order such assembly at shop for verification. The Contractor shall comply with such instructions without claiming any extra cost.

#### 2.8.4 SHOP ASSEMBLY

2.8.4.1 *The steelwork shall be temporarily shop assembled, as necessary, so that the accuracy of fit may be checked before dispatch. The parts shall be shop assembled with a sufficient number of parallel drifts to bring and keep the parts in place*

2.8.4.2 *Since parts drilled or punched, with templates having steel bushes shall be similar and, as such, interchangeable, such steelwork may be shop erected in part only, as agreed by the Engineer.*

#### 2.8.5 ASSEMBLY

2.8.5.1 *All parts assembled for bolting shall be in close contact over the whole surface.*

2.8.5.2 *The component parts shall be so assembled that they are neither twisted nor otherwise damaged. Specified cambers, if any, shall be provided.*

2.8.5.3 *All parts of bolted and welded members shall be held firmly in position by means of jigs or clamps while bolting or welding. No drifting of holes shall be permitted, except to draw the parts together and no drift used shall be larger than the nominal diameter of the bolt. Drifting done during assembling shall not distort the metal or enlarge the holes.*

2.8.5.4 *Trial assemblies shall be carried out at the fabrication stage to ensure accuracy of workmanship, and these checks shall be witnessed by the Engineer/*





*Authorised inspecting agency. Such trial assemblies shall be at the cost of the contractor.*

#### 2.8.5.5 FIELD BOLTS

- a) Requirements stipulated under bolting shall apply for field bolts also. Field bolts nuts and washers shall be furnished by the Contractor in excess of the nominal numbers required. He shall supply the full number of bolts, nuts and washers and other necessary fittings required completing the work, together with the additional bolts, nuts and washers totaling to 10% of the requirement subject to minimum of 10 Nos.
- b) At the time of assembly, the surfaces in contact shall be free of paint or any other applied finish, oil, dirt, loose rust, loose scale, burrs and other defects which would prevent solid seating of the parts or would interfere with the development of friction between them.
- c) If any other surface condition, including a machined surface, is specified, it shall be the responsibility of the Contractor to work within the slip factor specified for the particular case.
- d) Each bolt and nut shall be assembled with washers of appropriate shape, quality and number in cases where plane parallel surfaces are involved. Such washers shall be placed under the bolt head or the nut, whichever is to be rotated during the tightening operation. The rotated nut or bolt head shall be tightened against a surface normal to the bolt axis, and the appropriate tapered washer shall be, used when the surfaces are not parallel. The angle between the bolt axis and the surface under the non-rotating component (i.e. the bolt head or the nut) shall be  $90 + 3$  degree. For angles outside these limits, a tapered washer shall be placed under the non-rotating component. Tapered washers shall be correctly positioned.
- e) No gasket or other flexible material shall be placed between the holes. The holes in parts to be joined shall be sufficiently well aligned to permit bolts to be freely placed in position. Driving of bolts is not permitted. The nuts shall be placed so that the identification marks are clearly visible after tightening. Nut and bolts shall always be tightened in a staggered pattern and where there are more than four bolts in any one joint, they shall be tightened from the centre of the joint outwards.
- f) If, after final tightening, a nut or bolt is slackened off for any reason, the bolt, nut and washer or washers shall be discarded and not used again.

#### 2.8.6 MARKING OF MEMBERS

After checking and inspection, all members shall be marked for identification during erection. This mark shall correspond to distinguishing marks on approved erection drawings and shall be legibly painted and stamped on it. The erection mark shall be stamped with a metal dye with figures at least 20 mm high and to such optimum depth as to be clearly visible, even after a member is galvanized.





All erection marks shall be on the outer surface of all sections and near one end, but clear of bolt-holes. The marking shall be so stamped that they are easily discernible when sorting out members. The stamped marking shall be encircled boldly by a distinguishable paint to facilitate easy location. Erection marks on like pieces shall be at identical location. Members having lengths of 7.0 m or more shall have the erection mark at both ends.

2.8.6.1 *Each fabricated member, whether assembled prior to dispatch or not so assembled, shall bear an erection mark, which will help to identify the member and its position in respect of the whole structure, to facilitate re-erection at site. This erection mark shall be incorporated in the shop detail and erection drawings.*

#### 2.8.7 ERRORS

2.8.7.1 *Any error in shop work which prevents proper assembling and fitting up of parts in the field by moderate use of drift pins or moderate amount of reaming will be classified by the Engineer as defective workmanship. All charges incurred by the Engineer either directly or indirectly because of the poor workmanship will be deducted from the amount due to the Contractor before payment is made. The amount of such deduction will consist of the sum total of the costs of labour direct or indirect, material, plant, transportation, equipment rental and overhead expenses. In case the Engineer chooses to reject the material because of poor workmanship, the cost of all handling and returning the material to the Contractor, if he so desires, shall entirely be to the Contractor's account. All the replacement in the concrete to the concrete contractor. It should include providing layout drawings to the concrete contractor for placement of such inserts into concrete.*

### 2.9 ERECTION

2.9.1 Erection of structural steel fabricated components shall be done generally in accordance with provisions of IS: 800 2007.

2.9.2 Before starting of erection work, the contractor shall ensure the fulfilment of the following activities: -

- a). The contractor shall submit, for examination by the Engineer, detailed particulars of his proposed methods of erection of the superstructure steelwork, together with complete calculations relating to strength and deflection. If the erection scheme necessitates the attachment of strength steelwork to the permanent steel work, the contractor shall submit, for approval of the Engineer, the methods he proposes for making good the permanent steelwork after removing the temporary work. The contractor shall also submit the design and fabrication drawings including detailed calculations of temporary nose, counter weight, all temporary support, staging, braces etc. required for safe erection, for approval of the Engineer.
- b). The contractor shall provide all construction and transport equipment, tools, tackle, and consumables, materials, labour and supervision required for the erection of the structural steelwork.





- c). Handling, assembling, bolting, welding and satisfactory installation of all fabricated structural steel materials in proper location, according to approved erection drawings and/or as directed by the Engineer.
- d). Setting out, aligning, plumbing, leveling, bolting, welding and securely fixing the fabricated steel structures in accordance with the erection scheme, or as directed by the Engineer.

2.9.3 Grouting under base plates shall be done after erection of the structural steel, unless otherwise approved by the Engineer. All bearing plates and bearing assemblies shall be set level and to the elevations shown on drawings. These shall be shimmed with approved means and grouted to ensure full bearing on the supporting substrate regardless of the tolerances otherwise permitted. The grout to be used in superstructure or stanchion bases shall be shrink resistant grouting compound of approved make and manufacture and shall have a 28 days compressive strength of at least 30 N/sqmm. The surfaces which have to receive the grout shall be thoroughly cleaned immediately prior to the grouting operation. The grout shall be carefully worked under the base plates and shall completely fill the space under the base plates. After the grout has had its initial set, the grout shall be cut back flush with the base plate as shown in drawings and surplus grouting material removed. The surplus material thus removed shall not be re-used. If inserts in concrete are required, the contractor shall furnish all inserts including any reinforcement required for embedding in the concrete to the concrete contractor. It should include providing layout drawings to the concrete contractor for placement of such inserts into concrete.

#### 2.9.4 ERECTION TOLERANCES

Erection tolerances shall be as per table-1 of ANNEXURE-A.

### 2.10 QUALITY CONTROL & TESTING REQUIREMENTS

2.10.1 Quality Control through established testing norms of the welded structural steelwork by Engineer in charge.

2.10.1.1 *The Contractor shall submit the following:*

- Quality plan for approval for fabrication as well as erection.
- Proposed overall schedule for documentation of shop drawings, Plan / procedures and records, submission of procedure of fabrication.
- The contractor shall himself inspect all materials and shop work to satisfy the specified tolerance limits and quality norms before the same are inspected by Engineer in charge.





2.10.1.2 The contractor shall through appropriate planning and continuous measurements in the workshop and the erection at site, ensure that the tolerance specified in ANNEXURE-A are strictly adhered to.

2.10.2 Fabricating agency shall have in house facilities for all testing of weld.

2.10.3 VISUAL EXAMINATION

The contractor shall conduct visual examination and measurement of the external dimensions of welds for all joints. Before examining the welded joints, areas close to it on both sides of the weld for a width not less than 20 mm shall be cleaned of slag and other impurities. Examination shall be done by a magnifying glass which has a magnification power of ten (10) and measuring instrument which has an accuracy of + 0.1 mm or by weld gauges. Welded joints shall be examined from both sides. The contractor shall examine the following during the visual checks.

- i) Correctness and shape of the welded joints
- ii) Incomplete penetration of weld metal.
- iii) Influx
- iv) Burns
- v) Unwelded craters
- vi) Undercuts
- vii) Cracks in welded spots and heat affected zones
- viii) Porosity in welds and spot welds
- ix) Compression in welded joints as a result of electrode impact while carrying out contact welding
- x) Displacement of welded element

The contractor shall, document all data as per sound practices.

2.10.4 In order to exercise proper control of the quality of the welding, Contractor shall enforce methods of control as tabulated below:

Purpose	Control subjects	Methods of control
1	2	3
1. Control of welding materials and basic metal quality	Quality control of electrodes, welding wire, flux and protective gases.  Checking of quality and Weldability of the basic metal and welded members.	Weldability test to determine the technological properties of materials.  Mechanical test of weld metal.  Metalographical investigations of welds macro-structure and microstructure  Checking of weld metal resistance for intercrystalline corrosion. Study if weld metal solidity by physical control methods.





2. Checking of welders qualifications	Welding of specimens for quality determination	Mechanical tests, metalographical investigation & checking of welded joints by physical control methods
3. Control of welded joint quality	Control of assembly accuracy and technological welding process	Checking of assembly quality & centering of welded members Checking of welding equipment conditions. Checking correctness of welding procedure. Visual examination of welds

#### 2.10.5 Mechanical Test

The Contractor shall carry out various mechanical tests to determine weld-ability, metal alloyability, and nature of break, correct size and type of electrodes, degree of pre-heat and post-heat treatment. The type, scope and sample of various mechanical tests shall be determined in agreement with the purchaser. The number of tests conducted shall depend on the result obtained to satisfy the Engineer that the correct type and size of electrode, degree of pre-heating and post-heating and weld-ability of metal are being followed.

#### 2.10.6 Dye Penetration Test

Where welds are required to be examined by dye penetration inspection method, such tests shall be carried out in accordance with IS: 3658.

#### 2.10.7 Radiography Test

Whether instructed by Engineer in charge, or not, all 'Butt' welds shall be inspected by radiographic examination method. Such examination shall be done in accordance with the recommendations of IS: 1182.

Radiography test shall be conducted by the contractor to determine gas inclusion (blow holes, hollows) slag inclusion, shallow welds and cracks for 100 % lengths all butt joints. Before conducting the examination the welded joints shall be cleaned of slag and scales and visually examined. The welds shall be marked into separate portions depending on the length of photograph. The length of photograph shall be such as to ensure that there are no distortions and shall reveal the defect correctly. The length shall not be more than 0.75 of the focal distance and the width of the photograph would depend on the width of the welded joint plus 20 mm on either side of the weld. The cassette with film shall be protected by sheet of lead or equivalent of proper thickness against incidental, diffused and secondary radiation.

The direction of the ray with relation to the film shall be as specified hereunder.

Welds of butt joints without edge slopes with edge processing shall be examined by central ray directed at right angles to the weld.

In special cases examination of welds with inclined rays directed along edge slopes may be permitted by the Engineer/ Authorised inspecting agency.

Lap joints shall be examined by directing rays at 45 degree to the bottom plate. Welds in T-joints, without any edge preparation shall be examined by rays directed at 45 degree to the weld. Angle

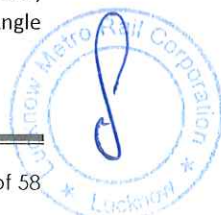



welds in lap and tee-joints shall be examined by the rays in opposite direction, i.e. the film will be on the side of the weld. Weld in angle joints shall be checked by directing ray along the bisector of the angle between the welded elements. Opposite direction of the ray and location of the film may also be permitted by the Employer.

#### 2.10.8 Ultrasonic Test

Ultrasonic test shall be conducted by the contractor to detect gas inclusion (pores), slag inclusion, shallow welds, cracks, lamination and friability etc for the fillet joints. Prior to starting of ultrasonic test the welded joint shall be thoroughly cleaned of slag and other material. Surface of the basic metal adjacent to welded joint on both sides shall be mechanically cleaned by the grinder or a metal brush to provide the contact of the whole ultrasonic probe surface with surface of basic metal. The width of the clean surface shall be as directed by the Engineer/ Authorised inspecting agency. The welded joint then shall be covered with a thin coat of transformer oil, turbine or machine oil to ensure acoustic contact. The joints so treated shall be marked and the marks shall be entered into the documentation, subsequent to this, ultrasonic test shall be carried out as directed by the Engineer. Unless otherwise directed by the Engineer 10% of welds shall be subjected to ultrasonic testing. Engineer may at his discretion reduce the frequency of such tests depending on the performance record of earlier tests.

#### 2.10.9 Magnetic particle Test

Only where the Engineer in charge requires that flaw-detection of welds be done by 'magnetic particle test', in such cases the tests are to be done in accordance with IS: 3703. If heat treatment is performed, the completed weld shall be examined after the heat treatment. All defects shall be repaired and retested. Magnetic particle tests shall be carried out using alternating current. Direct current may be used with the explicit written permission of the Engineer.

### 2.11 PAINTING OF STRUCTURAL STEEL WORK

#### 2.11.1 Paint

1. All paint delivered to the fabrication shop shall be ready mixed, in original sealed containers, as packed by the paint manufacturers. Addition of thinners shall not be permitted.
2. Opened containers of Paint shall be stirred frequently to keep the pigment in suspension

#### 2.11.2 Storage of Paints

1. All paints shall be stored strictly in accordance with the requirements laid down by the paint manufacturers. The storage area shall be well ventilated and protected from sparks, flame, direct exposure to sun or excessive heat, preferably located in an isolated room or in a separate building.
2. All paint containers shall be clearly labeled to show paint identification, date of manufacture, batch number, order number and special instructions in legible form. The containers shall be opened only at the time of use. Paints that have liveried, gelled or otherwise deteriorated during storage, shall not be used. Paints, for which the shelf life specified by the supplier has expired, shall not be used without inspection and approval by the Engineer.





### 2.11.3 Execution

### 2.11.4 Paint System

- 1 In general, except where specified otherwise in approved shop drawings Sand blasting of steel surfaces shall be carried out in accordance with IS:1477.
- 2 Painting work shall be carried out as follows:

DESCRIPTION	GENERAL SURFACE	
	FABRICATION SHOP	ERECTION SITE
	<b>EXTERNAL SURFACES</b>	<b>INTERNAL SURFACES</b>
Surface Treatment	Abrasive blast cleaning to minimum SA-2.5 SIS-055900 near – white blast cleaning	Abrasive blast cleaning to minimum SA-2.5 SIS-055900 near – white blast cleaning
1 <sup>st</sup> Under-Coat	Inorganic zinc silicate primer with 80% Zinc on dry film by weight (self curing solvent type) DFT – 75µm. The primer should be applied by spray only.	Epoxy zinc phosphate primer polyamide cured DFT-70µm. The primer should be applied by spray only.
2 <sup>nd</sup> Under-Coat	Epoxy zinc phosphate primer polyamide cured DFT-40µm. The primer should be applied by spray or brush only.	Epoxy zinc phosphate primer polyamide cured DFT-35µm. The primer should be applied by spray or brush only.
3 <sup>rd</sup> Under-Coat	Epoxy zinc phosphate primer polyamide cured DFT-35µm. The primer should be applied by spray only.	Polyamide cured coal tar epoxy coating DFT 100µm.
4 <sup>th</sup> Under-Coat	Epoxy high build micaceous iron oxide coating polyamide cured DFT-120µm. The M10 Pigment shall be of lamellar type. The primer should be applied by spray only. Stripe coat of Epoxy M10 30-40 µm applied by brush at weld, edges and corners.	Polyamide cured coal tar epoxy coating DFT - 100µm.
<b>Erection Site</b>	<b>External Surfaces</b>	<b>Internal Surfaces</b>
Intermediate Coat	Acrylic polyurethane finish aliphatic isocyanate cured DFT-30µm shall be Bergerthane or approved equivalent applied by spray or brush in approved colour.	NA
Finish Coat	Acrylic polyurethane finish aliphatic isocyanate cured DFT-30µm applied by spray or brush in approved colour.	NA

INTERNAL SURFACE = Internal surface are those which will become inaccessible after fabrication and are not prone to humidity and moisture from the atmosphere.

EXTERNAL SURFACE = All other surfaces which are prone to humidity and moisture from the atmosphere.

The following precautions must be taken:

- a. After abrasive blast cleaning, the first undercoat (primer coat) should be applied well before surface deterioration.
- b. At least EPOXY MIO coating application should be completed before giving any long over coating interval for external surface.
- c. At least up to one coat of coal tar epoxy shall be completed before giving any long over coating interval for internal surface.





- d. Over coating intervals, application parameters shall conform to manufacturer's instruction manual.
- e. The DFT (Dry film thickness) shall be measured after completion of each coat.

#### 2.11.5 Surface Preparation

##### 2.11.6 General

All surfaces shall be cleaned of loose substances and foreign materials. e. g. dirt, rust, scale, oil, grease, welding flux etc so that the prime coat adheres to the original metal surface. The work shall be carried out in accordance with IS: 1477 (1971) (Part I). Any oil, grease, dust or foreign matter deposited on the surface after preparation shall be removed and care shall be taken to ensure that the surface is not contaminated with acids, alkalis or other corrosive chemicals. The primer coat shall be applied immediately after the surface preparation is completed.

Before the application of any paint the surfaces to be treated shall be thoroughly cleaned freed from all scale, loose paint, rust and other deleterious matters. Oil and grease shall be removed from the surface by washing with solvents or with a detergent solution before blast cleaning operation of metal polish with metal pellets. If any traces of oil or grease remain after blasting they shall be removed by solvent cleaning and the area will be re-blasted thereafter.

All welding areas shall be given special attention for removal of weld flux slag, weld metal splatter, weld head oxides, weld flux fumes, silvers and other foreign objects before blasting. If deemed necessary by the Engineer, acid washing and subsequent washing with clean water shall be used. Any rough seams will have to be ground and must be inspected and approved by the Engineer before application of the coatings.

All structural steel to be painted shall be cleaned. Blast cleaning in accordance with SA 2 1/2 Near-White Blast cleaning (equivalent Swedish Standard SIS 055900). For SA 2 1/2 the profile should be in the range of 40-70 microns and shall be measured with comparator. Mill scale, rust and foreign matter shall be removed to the extent that the only traces remaining are light stains in the form of spots or stripes. Finally the surface shall be cleaned with a vacuum cleaner or clean dry compressed air.

The blast cleaning shall produce a surface roughness complying with the one specified by the paint manufacturer for the primer concerned. If, cleaned surfaces are rusted or are contaminated with foreign material before painting is accomplished they shall be re-cleaned by the Contractor at his own expenses.

The surface shall be cleaned by impingement of abrasive materials, such as grit of cast iron, malleable iron, steel or synthetic material, at high velocity created by clean and dry compressed air blast. Prior to application of the blast, heavy deposits of oil and grease shall be removed by solvent cleaning and excessive surface scale removed by hand tool or power tool cleaning.

##### 2.11.7 Mixing and Thinning

1. All ingredients in a paint container shall be thoroughly mixed to break-up lumps and disperse pigments, before use and during application, to maintain homogeneity. All pigmented paints shall be strained after mixing to remove skins and other undesirable matters.
2. Dry pigments, pastes, tinting pastes and colours shall be mixed and/or made into paint so that all dry powders get wetted by vehicles and lumps and particles are uniformly dispersed.
3. Additives that are received separate such as curing agents, catalysts, hardeners etc. shall be added to the paint as per the manufacturers instructions. These shall be promptly used within the pot life specified by the manufacturers and unused paint thereafter shall be discarded.



4. Thinners shall not be used unless essential for proper application of the paint. Where thinners are used, they shall be added during the mixing process and the type and quantity of thinner shall be in accordance with the instructions of paint manufacturer.

#### 2.11.8 Paint Application

1. Paint shall be applied in accordance with the manufacturer recommendations, as supplemented by these Specifications. The work shall generally follow IS:1477- (Part II). Prior approval of the Engineer shall be taken in respect of all primers and/or paints before their use in the works.
2. Paint shall generally be applied by brushing except that spraying may be use for finish coats only when brushing may damage the prime coats. Roller coat or other method of paint application shall not be used unless specifically authorized.
3. Spraying paint shall not be adopted on red lead or zinc rich paints. Daubers may be used only when no other method is practicable for proper application in difficult accessible areas.
4. Paint shall not be applied when the ambient temperature is 10°C and below. For paints which dry by chemical reaction the temperature requirements specified by the manufacturer shall be met with. Also, paint shall not be applied in rain, wind, fog or at relative humidity of 80% and above or when the surface temperature is below dew point, resulting in condensation of moisture. Any wet paint exposed to damaging weather conditions shall be inspected after drying and the damaged area repainted after removal of the paint.

Each coat of paint shall be continuous, free of pores and of even film thickness without thin spots. The film thickness shall not be so great as to detrimentally affect either the appearance or the service life of the paint.

The first coat of paint shall be applied within 4 hours after surface preparation and/or before rusting or contamination occurs.

Each coat of paint shall be allowed to dry sufficiently before application of the next coat, to avoid damages such as lifting or loss of adhesion. Undercoats having glossy surface shall be roughened by mild sand papering to improve adhesion of subsequent coats. Successive coats of same colour shall be tinted. Whenever practical, to produce contrasts and help in identifying the progress of the work.

#### 2.11.9 Brush Application

1. Proper brushes shall be selected for a specific work piece. Round or oval brushes which conform to IS: 487 are better suited for irregular surfaces, whereas flat brushes which conform to IS: 384 are convenient for large flat areas. The width of flat brushes shall not generally exceed 125mm.
2. Paint shall be applied in short strokes depositing a uniform amount of paint in each stroke followed by brushing the paint into all surface irregularities, crevices and corners and finally smoothening or leveling the paint film with long and light strokes at about right angles to the first short strokes. All runs and sags shall be brushed out. The brush marks left in the applied paint shall be as few as practicable.





#### 2.11.10 2.11.8 Spray Application

1. The spraying equipments shall be compatible with the paint material and provided with necessary gauges and controls. The equipment shall be cleaned of dirt, dried paint, foreign matter and solvent before use.
2. The paint shall be applied by holding the gun perpendicular to the surface at a suitable distance and moved in a pattern so as to ensure deposition of a uniform wet layer of paint. All runs and sags shall be brushed out immediately. Areas not accessible to spray shall be painted by brush or dauber.
3. Water trap acceptable to Engineer/ Authorised inspecting agency shall be furnished and installed on all equipment used in spray painting.

#### 2.11.11 Shop Painting

1. The painting system specified in Table shall be followed. Surfaces, which will be inaccessible after field assembly, shall receive the full-specified protective treatment before assembly.
2. Surfaces in contact during shop assembly shall not be painted. Surfaces which can not be painted but require protection shall be given a rust inhibitive grease conforming to IS:958-1975 or solvent deposited compound conforming to IS: 1153 (1975) or IS: 1674 (1960) or treated as specified in the drawing.
3. Surface to be in contact with concrete shall not be painted.
4. The shop coats shall be continuous over all edges, including ends meant for jointing at site by bolting, except where the paint could be detrimental to bolting. In such cases, no paint shall be applied within 50mm, and the unprotected surface shall be given a coat of corrosion inhibitive compound.
5. The unpainted area shall be cleaned prior to welding. The welded joint shall be cleaned and deslagged, and immediately after covered by the same paint as has been used for the remaining surface.

#### 2.11.12 Protection of Paintwork

- (i) The Contractor shall provide measures as necessary to prevent damage to the work and to other property or persons from all cleaning and painting operations. Paint or paint stains which result in other unsightly appearance on surface not designated to be painted shall be removed or obliterated by the contractor at his cost.
- (ii) All painted surfaces that in the opinion of the Engineer/ Authorised inspecting agency are damaged in anyway, shall be repaired by the contractor at his cost with materials and to a condition equal to that of the requirements specified in these specifications.
- (iii) Upon painted surfaces that in the opinion of any other work that would cause dust, grease or foreign materials to be deposited upon the painted surfaces, the painted surfaces shall be thoroughly cleaned.
- (iv) Level 2, Assessment of dust on steel surfaces by pressure sensitive tape method as per IS 8502 part 3.
- (v) The areas for high-strength bolts shall be protected by masking tape against undercoat application at the fabrication shop. Immediately prior to erection any rust in the paint area shall be removed by power wire brushing to a standard equivalent to SA3.
- (vi) Acceptance criteria for adhesion test should be 5A/4A as per ASTM D 3359.



2.11.13 Contractor shall make provision for requisite site painting to all fabricated steelwork, as per requirements of related specifications of the painting.

## 2.12 Repair of Paint Defects:

All damage to the previous paint shall be repaired. All loose paints shall be removed back to firm edge. Surface irregularities and contaminants shall be removed. Hard, glossy surfaces may require abrading to obtain a suitable surface for painting. Surfaces, which are to be over coated and which have become contaminated shall be either be solvent cleaned in accordance with SSPC-SP-1 "Solvent Cleaning" or high pressure fresh water washed and if required, a suitable detergent may be used.

## 2.13 Inspection :

**Testing :** The final paint shall be free from obvious defects and shall be tested by the contractor as follows :

**Film Thickness:** All dry-film thickness limits as specified shall be strictly adhered to. It is recommended that, in order to achieve the specified dry-film thickness, frequent checks of wet-film thickness are to be carried during the paint application with wet-film thickness gauges such as the Elcometer wheel or comb type wheel gauge. The dry film thickness of individual coats and of the total coating system shall be checked at random over an area representative of the total work. A minimum of 5 readings shall be taken for each 10 m<sup>2</sup> of coated surface. For a surface area less than 10m<sup>2</sup> a minimum of 3 readings shall be taken. Additional readings shall be taken if there has been any changes in application of equipments, spray nozzle size, thinning of paint, etc.

**Inspection:** The application work to be inspected at all stages and finished paint work shall have the correct shade, degree of gloss and evenness and be free from defects such as cracks, holidays, runs sags, wrinkles, patches, brush or roller marks, r other defects that may be detrimental to the quality of the coating. Prior to acceptance of the paintwork a final inspection shall be made.

## 2.14 MEASUREMENT

Measurement for payment shall be the plan area of the building calculated on the Center lines of peripheral columns. For variation of height increasing/decreasing by 0.5 m over the stipulated height of building, no extra payment shall be made.





## PART –2: SPECIAL REQUIREMENTS FOR INDIVIDUAL BUILDINGS

### A.0 INSPECTION BAY

- A.1 Roof elements in the bay are required to support runway beams for under-slung EOT cranes. Deflection limit for these roof rafters shall be restricted to span / 750.

Runway beams should be suspended from roof rafters such that bottom levels of all runway beams are at specified elevation (to be got confirmed from Engineer-in Charge. All such hangers shall be properly braced longitudinally and transversely to prevent sway.

- A.2 Two numbers of under-slung cranes (lifting capacity crane is 1.5T) are required to operate within the bay. For the purpose of design, all four cranes shall be considered to have wheel- bases of 1600 mm. Maximum wheel load shall be taken as 1.0 T and corresponding minimum wheel load shall be taken as 0.5 T. When the cranes are centrally positioned, all four wheels should be considered as transferring 0.75 T of reaction on to the runway beams. Roof rafters and runway beams shall be designed for these specific loads.

- A.3 A uniform load of 15 Kg / sqm of plan area shall be considered as load from suspended utilities to be supported by the structure.

- A.4 Inspection bay would have elevated inspection platforms made in steel. The deck of the platform is to be built out of 5 mm thick chequered plates. The central platform is supported on posts at 5.0 m centers. Side platforms are alternately supported on main columns and one intermediate post for each span. The platforms shall be provided with handrails as indicated in Drawings. Design load for these platforms shall include a point load of 1.25 T that may be placed any where on the deck. When one such load is considered at one location, the other load need not be considered at less than a distance of 10 m from the first load. In addition the platform shall be designed for a uniform imposed load of 250 kg / sqm.

- A.5 Rail tracks in the Inspection bay are to be supported on steel posts spaced 1200 mm centers along the track, as indicated in the drawings. The posts are to be designed for full axle load from a Standard Gauge [S G] Rail Coach, as given below: -

No. of axles per coach	= 4 nos.
No. of bogies per coach	= 2 nos.
No. of axles per bogie	= 2 nos.
Distance between bogie center to bogie centre	= 15,000 mm
Bogie wheel centre	= 2300 mm
Overall coach length	= 22,500 mm

Axleload: Maximum = 17.0 T; Minimum = 8.0 T

### B.0 WORKSHOP

- B.1 There are one bay for workshop with three tracks. The width of each bays are 28.5 m.
- B.2 Workshop shall have two EOT cranes that would operate in tandem for full length of shop. Crane rail level for all the bays shall be at an elevation of 8500 mm from shop floor level [top of Rail Level].
- B.3 Main hoist lifting: The repair bay EOT Crane main hoist capacity will be 15T. and auxiliary hoist capacity shall be of 2T. each.



Tender KNPCC-03: Civil, PEB and E&M works for construction of depot cum workshop, including structural, architectural, plumbing, drainage, external development, road works, electrical, mechanical, VAC, fire fighting, fire detection etc. at Govt. Polytechnic Depot for IIT Kanpur to Naubasta Corridor-1 of Kanpur Metro.

B.4 Wheel-base for all cranes should be considered as 3900 mm [This dimension of wheel base shall have to be got confirmed from the Engineer-in Charge before starting 'Final Design'. Minimum distance between centers of wheels of two cranes in tandem shall be considered as 600 mm.

B.5 For design of gantry girders and for arriving at maximum and minimum reactions at end and intermediate columns, wheel reactions for the cranes shall be as follows: -

Location	Main hoist capacity (T)	Wheel reactions	
		Maximum (T)	Minimum (T)
1. Light Lifting Bay	15.0	15.0	4.5
2. Heavy Repair Bay	15.0	15.0	4.5

B.6 Uniform load of 15 Kg / sqm of plan area shall be considered as load from suspended utilities to be supported by the structure.





### 3. PRE-COATED STEEL SHEETING FOR ROOFS AND WALLS

#### 3.1 SCOPE OF WORK

Coated steel profiled sheet of approved colour shall be installed at roof and side cladding on steel framing or on any other material at any other location as directed by the Engineer, and shall be executed as per the details shown on the "Good for Construction" and approved shop drawings and as per specialist manufacturers recommendation, complete in all respects. The work shall be executed in flat, tapered, curved form both in plan and section as required.

##### 3.1.1 MATERIALS

The base material of sheet shall be polyester coated high tensile cold rolled steel as per AS 1397, coating class AZ 150 (min. 150 gm/m<sup>2</sup> zinc aluminium alloy coating mass, total of both sides) in 0.45 BMT (Base Metal Thickness) with hot-dip metallic coating of aluminium zinc alloy (ALUMINIUM 55% AND ZINC 45 %) and having a yield strength not less than 550 Mpa.

##### 3.1.2 COATING

Exterior coating shall be silicone modified polyester (SMP) with 30-50% silicone content (min.) of approved colour and 35 microns total thickness consisting of 20 microns top coat over 5 micron polyester back coat and a 5 micron primer coats on both surfaces including side and end laps.

##### 3.1.3 SHEETING PROFILE

Sheets shall be profiled with 28-30 mm high crests at 186-333 mm centres, 920-1000 mm cover width. Lengths up to 12 m shall be in single sheets. Larger lengths, if practicable should be used in longer slopes. Sheets to have wide pans with intermediate stiffening ribs for efficient water shedding and strength. Sheets shall be factory cut and supplied in required sizes based on approved shop drawings.

##### 3.1.4 SANDWICH PANELS (Double sheeting with Insulation)

Sandwich Panel shall be manufactured by the press injection method to produce a rigid polyurethane foam (30mm thick of 40 Kg/cum density) core between exterior steel facings. The manufacturing process shall be carefully controlled with steel facings maintained at around 40 °C during the injection process to ensure proper reaction and adhesion. Also the pressure on the moulds shall not be released till completion of erection. The panels to possess a curved profile as per the overall profile of the roof (drawings attached).

##### 3.1.5 FIXING

Sheets shall be fixed to roof purlins and side rails / runners at crest as per manufacturer's recommendation and water-tightness provisions using polymer coated galvanised hex head self-drilling self tapping (SDST) screws with integral washers and EPDM seals. The side laps in sheets shall be provided with sealing tapes and screw fasteners.



Before laying the sheets the purlin spacing shall be verified. The sheets shall be laid starting from the eaves or from bottom upward in case of cladding (IS: 3007). The sheets shall be laid from the end of the building away from prevailing wind so that exposed edges face down wind. The laps shall be as shown in the approved shop drawing.

If slope of roof is less than 15 degree, the end lap on roof shall be minimum 225mm and single length sheets with joint sealed with double sided self sticking tapes fixed between two sheets are to be provided.

The contractor shall ensure that panel erector is familiarised with erection procedure and all the supporting members are straight, level, plumb and true (according to AISC) before starting panel erection. Panels shall be erected according to approved shop drawings.

#### 3.1.6 SHOP DRAWINGS AND APPROVALS

Shop drawings shall be prepared for all sheeting work by the contractor and show the entire installation system including purlin layout, sheet layout, sizes and colour, fixing details etc. Shop drawings shall be submitted to the Engineer for his approval.

The Contractor shall submit catalogues, design calculations for sheet profile confirming safe distributed load capacity, samples of all items to be used and samples of workmanship for approval of the Engineer-in-Charge.

#### 3.1.7 ACCESSORIES

The specification for capping, flashing and trims materials shall be same as that for sheeting and shall be factory formed to required shape and profile based on shop drawings. Roofing accessories like flashings (straight or crimp curved), capping etc. shall be provided from similar coating as used for sheets and shall be fixed by means of self drilling self tapping screws with EPDM washer seals.

#### 3.1.8 TOLERANCES

Length	: +0-10mm
Cover width	: + or -6mm

#### 3.1.9 STRUCTURAL STABILITY AND GUARANTEE AGAINST RUSTING/CORROSION

The Contractor shall provide design calculations for sheeting taking into account wind loads, seismic and other code requirements and guarantee structural stability.

The contractor shall also give guarantee for the sheets against rusting/corrosion, leakages through laps and fasteners, colour fading etc. for a period of ten years.





### 3.2 RAIN WATER GUTTER

Rain water gutters shall be fabricated out of 3.15 mm thick galvanized M.S. Sheets. All arrangements for incorporating outlets for rainwater down take pipes shall be incorporated in the fabrication, as per approved drawings and instructions. Gutters shall be Hot-dip galvanized and painted as per painting specifications of structural steel work. Thickness of galvanized coating shall not be less than 50 microns. Connections between each section shall be made water-tight by site seal welding.

### 3.3 SPECIFICATION FOR LOUVERS:

The work for provision of Aluminium Louver pre powder coated for ventilation shall be for easy escape of hot air which accumulates at the roof of work shop shed to normalize the ambient temperature in depot shed and result the comfortable feeling of environment for workmen and normal working of machinery & plants. The work shall comprise:

- (i) Design, Fabrication, supply, modification, installation testing and commissioning as per drawing and BOQ.
- (ii) Louver shall consist extruded section of aluminium 4"x1" rectangular pipe frame, c-channel 2½" x ½" with metal framework of 3mm thick sheets, 1.5mm thick S-type louvers as per drawing enclosed.
- (iii) Louver bracket/frame shall be permanently fastened to the existing structure without damage.
- (iv) Any additional support and angle etc. required shall be aluminium and pure polyester pre powder coated before fabrication/installation.
- (v) All friction parts, fastenings or any part remaining, as machined / unpainted shall be coated with a product to protect them from corrosion until the unit is commissioned.
- (vi) The paint (if required) shall be done by two coat of epoxy/polyester paint and one coat of epoxy primer.
- (vii) The contractor shall arrange free of cost supply of resources, scaffolding, materials, tools, plant, transportation and manpower for fabrication and installation of the Louver.
- (viii) The contractor shall arrange free of cost all material, equipment and accessories even if not particularly mentioned, necessary to achieve a complete installation in perfect operating condition.
- (ix) The quantity specified in BOQ is approximate and is likely to vary as per site requirement and performance at the same rate as accepted by competent authority.

Note:

- a) Before taking up mass production of louvers, contractor will offer one sample to the LMRC engineer for inspection and approval.
- b) Before taking up fitment of louvers on a large scale, contractor will set up a mock up free of cost at site and will offer it to LMRC engineer for inspection and approval.



Tender KNPCC-03: Civil, PEB and E&M works for construction of depot cum workshop, including structural, architectural, plumbing, drainage, external development, road works, electrical, mechanical, VAC, fire fighting, fire detection etc. at Govt. Polytechnic Depot for IIT Kanpur to Naubasta Corridor-1 of Kanpur Metro.

---

### 3.4 MEASUREMENT

#### 3.4.1 METAL SHEETING FOR ROOFS AND WALLS

The quoted rates for sheeting work, covered by this specification shall include providing of all materials tools & tackle, plant, scaffolding as required labour, and all other work necessary to complete the job as per this specification and approved shop drawings. Rate shall cover for special accessories like ridge pieces, flashings, trims and the like, and bolts screws, sealants, tapes all inclusive.

Work shall be measured and paid for as per actual net area covered by sheets that includes all overlaps.





## 4. POLYCARBONATE SHEETS FOR ROOF LIGHTING

### 4.1 GENERAL

This section covers the requirements of providing, erecting and fixing of polycarbonate sheets of approved colour and approved transparency on roofs for the purpose of roof lighting. Sheets shall be procured from established and approved manufacturers.

### 4.2 MATERIAL

- Material to be used shall not be less than 3.0 mm thick, and shall be profiled to exactly match the profile of pre-coated metal sheets to be used for general roof and side claddings.
- Sheets shall be supplied in maximum lengths that can be transported and erected without causing damage to the sheets, but in any case the lengths shall not be less than 10.0 m.
- Material shall be free from scratches and other surface damages. These shall be stored in sheltered places and stacked with intermediate layers of soft puffed plastic sheets. Stacks shall be covered with and wrapped around with polyethylene sheets to prevent dust accumulation on the sheets.
- Material shall be U-V treated and shall be of tested quality. The contractor shall ensure that the manufacturer provides with the test certificates for the following properties: -

Test	Procedure	Results
<u>Flammability</u>		
Self ignition	ASTM 1929-3	570 °C
Smoke density	ASTM D 2843	54%
Burning extent	ASTM D 635	less than 1.0
<u>Weathering</u>		
Weathering evaluation	ASTM D 4364-84	Successful exposure to Concentrated Sunlight radiation
Colour change	ASTM D 2244	Not more than 3 units after 60 60 months
Light transmission	ASTM D 1003	Shall not decrease more than 10 points after 60 months

Test	Procedure	Results
------	-----------	---------



**Tender KNPCC-03:** Civil, PEB and E&M works for construction of depot cum workshop, including structural, architectural, plumbing, drainage, external development, road works, electrical, mechanical, VAC, fire fighting, fire deflection etc. at Govt. Polytechnic Depot for IIT Kanpur to Naubasta Corridor-1 of Kanpur Metro.

-Ditto-	-Ditto-	Shall not decrease by more than 6% after 10 years
Heat exposure	300oF / 25 mins	No darkening effect
Water penetration	ASTM E 331	No penetration
Impact	ASTM E 822-81	Repels hail storm of 25 mm at Velocity of 21m/sec
Expansion/contraction mm / m /°C		Linear thermal change of 0.065
U-V Filtration	Australian Standard No. 1067	Transmission less than 0.1%
Modulus of Elasticity	DIN 53457	24000 kg / sq cm

#### 4.3 SUBMITTAL

- Contractor shall submit test reports from manufacturer on all tests listed at clause 2.4.1.
- The contractor shall also submit a guarantee that the performance of the sheets supplied by him shall meet with the requirements of the test certificates to be produced by him.

#### 4.4 INSTALLATION

- 4.1 Sheets shall be installed in sequence as shown in approved shop drawings, and fixed to purlins with polymer coated, galvanized, hexagon headed self-drilling, self tapping screws.
- ✓ Side laps shall be as per manufacturers' specification. End laps shall be 225 mm. Joints with metal sheets shall be sealed with Butyl-based adhesive. The edges shall be sealed with silicone sealant as per manufacturers' specification, and then covered with butyl-based adhesive tapes.

#### 4.5 MEASUREMENT

Contractors quoted rates for sheeting work shall include all materials, tools, plants, all accessories including fasteners, adhesives, sealants, tapes etc. and labour, all temporary works complete to the requirement of these specifications and instructions

Work shall be measured and paid for on the actual net area of clear opening, excluding all overlaps at sides and ends.

##### Approved Manufacturers/ Supplier

All materials and products shall conform to the relevant standard specification, IS codes, ASTM and other relevant codes etc. and shall be of approved makes and design.





Tender KNPCC-03: Civil, PEB and E&M works for construction of depot cum workshop, including structural, architectural, plumbing, drainage, external development, road works, electrical, mechanical, VAC, fire fighting, fire detection etc. at Govt. Polytechnic Depot for IIT Kanpur to Naubasta Corridor-1 of Kanpur Metro.

---

The list of approved makes for products and materials is given below. Other equivalent manufacturers will only be considered with prior approval of the Employer in case of non-availability or unforeseen difficulties.

**List of Approved Manufacturers/ Suppliers**

1. Sabic (GE) Ltd
2. DanPalKibbutz



## 5. POLYCARBONATE SHEETS FOR NORTH LIGHTS AND WINDOWS

### 5.1 GENERAL :

This section covers the requirements of providing, erecting and fixing of Polycarbonate sheets of approved colour and approved transparency on windows and north lights for the purpose of lighting. Sheets shall be procured from established and approved manufacturers.

### 5.2 MATERIAL :

Providing and Fixing Microcell Panel System 12mm thick (minimum) conforming to specifications mentioned below.

The polycarbonate system shall consist of:

- Panel shall be 12mm thick (min.)
- Panel Width shall be not less than 900 mm to ensure best performance for wind uplift, vibration, oil canning and visual appearance.
- The panels shall be uniform in color with an integral Microcell core. In a cross section, the core shall be constructed of honeycomb cells not to exceed 4mm x 4mm.
- Weight of panel shall not be less than 2500 per square meter.
- Panels shall be manufactured with Vertical Standing Seam at both sides of the panel. Welding or gluing of upstands or standing seam is not acceptable.
- Snap-on connector to interlock the panels shall have a grip-lock double tooth locking mechanism to ensure maximum uplift capability & shall be of same color as that of panel for aesthetic appeal.
- End-cap/Aluminium U-Profile (mill finish) for ends.
- Panels shall be co-extruded UV protected and double tone with anti-glare softlite color on one side to prevent glare.
- Panel manufacturer should have project reference in India which is at least 6 years old for a single project not less than 1,500 m<sup>2</sup>.
- UV protected side shall always face the sun/top.

Panels shall be installed by a solution provider (agency) approved by the manufacturer. Approved agency must submit letter from manufacturer (dated not earlier than the date of issue of tender document).

Installer/Solution provider shall comply with all statutory regulations or/and compliances.

### 5.3 SUBMITTAL :

- 1) Contractor shall submit test reports from manufacturer on all tests.
- 2) The contractor shall also submit a guarantee that the performance of the sheets supplied by him shall meet with the requirements of the test certificates to be produced by him.





#### 5.4 MEASUREMENT :

- 1.1 Contractors quoted rates for sheeting work shall include all materials, tools, plants, all accessories including fasteners, adhesives, sealants, tapes etc. and labour, all temporary works complete to the requirement of these specifications and instructions
- Work shall be measured and paid for on the actual net area of clear opening, excluding all overlaps at sides and ends.

#### 5.5 APPROVED MANUFACTURURES/SUPPLIERS :

All materials and products shall conform to the relevant standard specification, IS codes, ASTM and other relevant codes etc. and shall be of approved makes and design.

The list of approved makes for products and materials is given below. Other equivalent manufacturers will only be considered with prior approval of the Employer in case of non-availability or unforeseen difficulties.

#### 5.6 List of Approved Manufacturers/ Suppliers

1. DANPALON
2. Poly U



## 6. TURBO VENTILATORS

### 6.1 General

The Turbo ventilators shall be packaged factory assembled and tested and complete in all respects and shall generally comply with the specifications as given in subsequent paragraphs.

### 6.2 Scope

The scope of this section comprises the supply, erection, testing and commissioning of Turbo ventilators conforming to these specifications and in accordance with the requirements in schedule of quantities. The scope including cutting openings in the roof sheeting, lifting the turbo ventilators to the location, fixing, flashing, installing, waterproofing all builder works as required.

- i) Turbo ventilators shall have a successful proven performance for not less than 5 years under the equivalent conditions to those required by the tender documents. Full technical details and evidence of suitability are required at the time of tendering.
- ii) The turbo ventilators shall meet International Standards and complete details of compliance shall be given with the submittals.
- iii) The approved vendor shall provide working drawings showing:
  - a) Fully dimensioned builder's work.
  - b) General arrangement of the complete turbo ventilators including water proofing.
- iv) Finishes and material of construction shall not be affected by gases handled by turbo ventilators or the local environment. The materials shall be resistant to the weather and solar radiation. Casings shall be complete with integral weatherproofing provisions suitable for direct fixing to the building structure.
- v) The wind driven turbo ventilator shall be extracting air from the buildings without causing leakage of rain / storm water.
- vi) The turbo ventilators shall be with vertical vanes.
- vii) Ball bearings shall be stainless steel and shall not be in the path of discharge / exhaust air to ensure greater bearing life and continued discharge efficiency.
- viii) The turbine head shall be installed on variable angle elbow of aluminium construction and further installed on FRP base sheet of 2.5mm thickness with UV stability. Stainless steel hardware shall be used with rubberized washers to prevent leakage.
- ix) The turbine head and variable angle elbow shall all be of aluminium construction. The spider and shaft shall be of stainless steel.
- x) The tenderer shall provide certification for resistance to leakage during rain as per Australian Standard AS : 2428.1 and resistance to wind velocity upto 55 mtr./sec.
- xi) Civil work required, roof sheet extension, modification work, cutting and closing of openings in roof sheets or sides of the roofing are included in the scope of contractor. Insulation retainers ring shall be provided between two sheets.





Tender KNPCC-03: Civil, PEB and E&M works for construction of depot cum workshop, including structural, architectural, plumbing, drainage, external development, road works, electrical, mechanical, VAC, fire fighting, fire detection etc. at Govt. Polytechnic Depot for IIT Kanpur to Naubasta Corridor-1 of Kanpur Metro.

---

- xii) The contractor shall make own arrangements for access to roofing sheets, life line to hook / tie safety belts, roof ladders / cat walks, electrical power supply required. All safety equipment, requirements shall be arranged by the contractor.
- xiii) The turbo ventilators shall be statically and dynamically balanced.
- xiv) The base sheets of turbo ventilators shall be matching the roof sheet profile to avoid leakage.
- xv) The material thickness of vanes / blades shall be not less than 0.71mm.
- xvi) The turbo ventilators shall be suitable for dusty, smoky, sooty, oily, harsh conditions.
- xvii) Special rubberized hardware shall be provided to prevent ingress of rain.
- xviii) There should be no air back draft.
- xix) Shaft shall be of stainless steel.
- xx) The turbo ventilator manufacturing process shall be rivet less or involve few rivets only.
- xxi) The top of roof sheeting of the building shall be of architectural profile. They shall fit on gradient.



**ANNEXURE-A**

(Refer Clause 10.1.2)

Tolerances mentioned below shall be achieved whether the entire structure or part thereof is erected and made in line, level and in plumb.

S.No.	Structure	Tolerance
<b>1</b>	<b>Columns</b>	
a	Deviation of axes at foundation level or at top of anchor level with respect to true axes: - About both directions	+ 5 mm / - 5 mm
b	Deviation in level of bearing surface with respect to true level At centre line	+ 3 mm / - 3 mm
c	Out of plumb-ness of column axis from true vertical, measured at top of Column: - For columns up to 15 m in height:	+/- 1/1000 of column height in mm -or- +/- 15 mm whichever is less.
i	For columns up to 15 m in height:	1/1000 of column height in mm -or- +/- 15 mm whichever is less.
ii	For columns exceeding 15 m in height	+/- 1/1000 of column height in mm-or- +/- 20 mm whichever is less.
<b>2.</b>	<b>Trusses and Beams</b>	
a	Shift at the center of span of the top chord member with respect to vertical plane passing through the center of bottom chord member	+/- 1/250 of truss height in mm-or- +/- 10 mm whichever is less.
b	Lateral shift of top chord of truss / beam at center of span from the vertical plane passing through the center of supports of the truss	+/- 1/1500 of span of truss in mm-or- +/- 5 mm whichever is less.
c	Lateral shift in location of truss / beam from its true vertical position	+/- 5 mm
d	Lateral shift in in-plane location of beam / purlin from true position:	+/- 5 mm
e	Deviation in difference of bearing levels of trusses or beams from true levels	+/- 10 mm for trusses -and- +/-5mm for beams





#### ANNEXURE -B

##### Approved Manufacturers/ Supplier

All materials and products shall conform to the relevant standard specification, IS codes, IRS and other relevant codes etc. and shall be of approved makes and design.

The list of approved makes for products and materials is given below. Other equivalent manufacturers will only be considered with prior approval of the Employer in case of non-availability or unforeseen difficulties.

##### List of Approved Manufacturers/ Suppliers

###### A. Steel

1. Steel Authority of India Ltd,  
Commercial Directorate,  
14th Floor, Hindustan Times House,  
18-20, K. G. Marg, New Delhi-110 001  
Telephone -011- 23355733, 23704699  
Fax No. 011- 23714403
2. The Tata Iron & Steel Co. Ltd.,  
Jeevan Tara Building, (First Floor)  
5, Sansad Marg,  
New Delhi-110 001  
Telephone -011-3342646
3. Jindal Steel & Power Limited,  
Corporate Office, Jindal Centre,  
12, Bhikaiji Cama Place,  
New Delhi-110 066  
Telephone -011-26188340-50, 26188360-75  
Fax No. 011-26161271
4. Essar Steel

###### B. Pre-coated Profiled Metal Sheetings

1. Blue Scope Steels Ltd.  
The Metropolitan, Plot No. 27, Survey No. 21,  
Wakewadi, Shivaji Nagar, Pune- 411005.  
Ph: 2066 218000; Fax: 2066 218001.
2. Ispat Profile India Ltd.
3. Essar Steel

###### C. Electrodes / Wires / Flux

1. Esab India  
71/1, Najafgarh Road,  
Moti Nagar,  
New Delhi-1100015  
Tel No-011-25172309, 9811206014  
Fax No- 011-25932207



Tender KNPCC-03: Civil, PEB and E&M works for construction of depot cum workshop, including structural, architectural, plumbing, drainage, external development, road works, electrical, mechanical, VAC, fire fighting, fire deflection etc. at Govt. Polytechnic Depot for IIT Kanpur to Naubasta Corridor-1 of Kanpur Metro.

---

2. Advani-Oerlikon,  
L. B. Shastri Marg, Bhandup-78  
Telephone 022 25611444, 25612566, 25642568f
3. D& H Welding Electrodes (India) Ltd.,  
Sector A, Plot-A, Industrial Area,  
Sanwer Road, Indore-452 003  
Telephone 0731-422445, Fax 0731422447
4. Maruti Weld Ltd.  
1-1, Kirti Nagar  
New Delhi – 110015  
Tele: 91-1141424888

**D. Bolts, Nuts and washers**

1. Unbrako, Precision Fasteners Limited,  
Post Box No. 80, 15, MIDC Industrial Area,  
Thane Belapur Road, Kalwa,  
Thane-400 601  
Telephone 022- 7692141  
Fax No. 022-769 1819 & 7691814
2. Deepak Fasteners,  
E-536, PHASE VI, Focal Point,  
Ludhiana – 141010  
Phone No.2531163, 2535390
3. Pooja Forge, Faridabad, Haryana

**E. Screws**

1. Hilti
2. Corro Shield, Chennai, Tamil Nadu

**F. Painting System**

1. Berger Paints India Limited,  
E-40/3, Okhla Industrial Area,  
Phase-II, New Delhi-110 020  
Phone 26383772, 4714, 4796, 7256  
Fax No. 26385644
2. PPG Asian Paints Pvt. Ltd  
158, Vidyanagar Marg  
CST Road, Dam Wooltex Compound,  
Kalinga, Santacruz (E),  
Mumbai - 400098
3. Jotun  
502, Boston House,





Tender KNPCC-03: Civil, PEB and E&M works for construction of depot cum workshop, including structural, architectural, plumbing, drainage, external development, road works, electrical, mechanical, VAC, fire fighting, fire detection etc. at Govt. Polytechnic Depot for IIT Kanpur to Naubasta Corridor-1 of Kanpur Metro.

---

5th Floor, Suren Road  
Behind Cinemax Theatre  
Chakala Andgeri (E)  
Mumbai - 400092

4. AKZONOBLE India Ltd.  
DLF Cyber Terraces,  
Building No.5  
DLF Cyber City – III  
Gurgaon - 122002



## ANNEXURE- C

### (Design Base Report)

#### DESIGN CRITERIA AND MATERIAL SPECIFICATIONS FOR PRE- ENGINEERED BUILDINGS (PEB)

- 1.0 For the purpose of preparing their offers, all bidders are required to follow the general and special requirements of design criteria and material specifications as laid down in this Annexure to the particular specifications.
- 2.0 Requirements given below are in addition to the Particular specifications laid down for the various items of work.
- 3.0 LMRC reserves the right to modify these requirements at the final design stage. Suppliers will not be entitled to claim extra over their quoted prices on account of such changes in requirements.

#### PART – 1: GENERAL REQUIREMENTS FOR ALL BUILDINGS

##### General

Pre-Engineered Buildings or building components wherever specified shall be designed, supplied and erected by a specialist agency called PEB manufacturer approved by the Engineer. All codes and standards for material, design, fabrication and erection shall generally be as indicated for structural steel work unless the following specifications call for a deviation otherwise. PEB manufacturer shall use Submerged Arc Welding for built-up sections, meeting the applicable requirements of the American Welding Society (A.W.S) D1.1.98.

The agency responsible for design, fabrication and erection shall not be allowed to sub-let any of the activities/operations to another sub-agency in anyway unless a prior written approval of the Engineer is taken. The agency for PEB should have an ISO 9001 certification for manufacture of PEBs. Contractor shall submit all design drawings, erection drawings, fabrication design and drawings for approval by LMRC/DDC prior to commencement of fabrication works.

##### Design Specifications for PEB Buildings

The PEB manufacturer shall be responsible for carrying out all the design of PEB's as per following relevant IS codes only.

- a) IS:800 Code of Practice for general construction in steel (Limit State Method)
- b) IS:801 Cold formed sections
- c) IS:811 Cold formed sections
- d) IS:875 Code of Practice for design loads for building and structure
- e) IS:2062 Steel for General Structural Purposes

Only in absence of design criteria not available in mentioned IS codes, reference can be made to other international codes/manuals as applicable to PEB's and same shall be subject to approval of LMRC in case of deviation from IS codes.

##### A.0 LOADING

The structure shall be designed for all loads, including the weight of structure, live load, wind or earthquake. Due consideration shall be given to loading during the construction/erection phase and accounted for in the design. The design to be cater for the proposed future expansion also.

##### A.1 DEAD LOAD

Self Weight of Structure including Purlins, Sheeting, Girts Bracings weight of turbo ventilators to be added as Dead load. etc.





## A.2 LIVE LOAD

(A.2.1) As per provisions of IS: 875 (Part – 2) for sloped roofs up to 10 deg. it shall be 0.75 KN/M<sup>2</sup>.

(A.2.2) Other Imposed loads -

Loads from suspended utilities, OHE fittings etc as per specific requirement of different buildings.

A.2.3) Material Handling loads supported on structures like EOT cranes, under-slung cranes, all as per specific requirement of individual buildings.

## A.3 WIND LOAD

As The design of PEB's are mainly governed by Wind load, no increase in permissible stresses is allowed for wind load combinations as per IS:800.

### Parameters

As per provision of IS: 875 (Part – 3), with the following parameters:

A.3.1) Basic wind speed: 47 m/s

A.3.2) Value of k<sub>1</sub>, corresponding to mean probable design life of building of 120 years: as per table –1 of IS: 875 (part-3). k<sub>1</sub> = 1.1

A.3.3) Value of k<sub>2</sub>, shall be taken corresponding to terrain category - 2 from Table –2 of IS: 875 (Part-3). Minimum value of k<sub>2</sub> shall be = 1.0

A.3.4) Value of k<sub>3</sub>, as per clause 5.3.3.1 of IS: 875 (Part-3) k<sub>3</sub> = 1.0

A.3.5) Local wind effects to be taken as per provisions of IS: 875 (Part-3), corresponding to building plan size, height, shape and direction of wind.

$$V_z = V_b \times k_1 \times k_2 \times k_3 = 47 \times 1.1 \times 1.0 \times 1.0 = 51.70 \text{ m/s}$$

$$P_z = 0.6 \times V_z^2 = 0.6 \times 51.70^2 = 1603.7 \text{ N/m}^2$$

Hence design minimum wind pressure shall be taken as 1.60kN/m<sup>2</sup>.

The local external wind pressure coefficient shall be taken strictly for the local zones as shown in relevant tables of IS:875-1987. The internal and local external coefficients shall be combined for design of roof sheeting, glass panels, individual cladding units, girts and purlins falling in high local pressure zones shown in relevant tables of IS:875.

A.3.6) The % area of openings and the front openings should be taken as larger than 20% for all of PEB buildings. Therefore the design internal pressure coefficient should be taken 0.70 as per clause 6.2.3.2 of IS:875(Part-3) for all PEB's structure shed.

## A.4 EARTHQUAKE LOAD

As per provisions of IS: 1893 for Zone –IV.

## A.5 VERTICAL DEFLECTION AND HORIZONTAL SWAY LIMITS:

a) Limiting Deflection: The limiting permissible vertical deflection for structural

Steel members shall be as specified below:



- Structures / structural components as per IS 800 2007 code.

b) The limiting permissible horizontal deflection for as per IS 800 2007 code

Where 'h' is height of building at eaves,

#### A.6 FRAME ANALYSIS:

The frame shall be analyzed with fixed base, suitable for future expansion along end walls, as given in the general arrangement drawings and specifications.

01. Loads as per clause 3.2 of IS-800 -2007 and IS-875, Design as per IS-800-2007.
02. Loading combinations as per Clause 3.5 and Table-4 IS-800-2007.
03. Deflection both lateral & Vertical as per Table 6 – IS-800-2007.
04. Design should be based on Limit State method.
05. Both Limit States of strength as well as serviceability should satisfy the performance requirements refer Clause 5.2.2.1 and 5.2.2.2 of IS-800-2007.
06. Factors governing the ultimate strength as per clause 5.5. of IS-800-2007 should be ensured.
07. Limit states of serviceability as per clause 5.6 of IS-800-2007 should be ensured.
08. Method of analysis may any one of the method prescribed as per clause 4.1 of IS-800-2007.
09. Notional Horizontal loads as applicable as per clause 4.3.6 should be applied on the structure and checked.

Effective length of comparison member should be as per clause 7.2 and maximum values of effective slenderness ratios should be as per Table 3 of IS-800-2007. Limiting width to thickness ratio of elements may be as per Table 2 of IS-800-2007. Transfer of Horizontal forces due to wind and EQ to the foundation should be ensured by proper means. Uplift due to wind and EQ should also be checked for beams and columns, purlins.

Expansion joint need not be given as per clause 3.10.3.2 of IS-800-2007 but longitudinal bracing 2 Nos. @ 50m to be provided (Ref. Fig.4). Columns should be treated as fixed at foundation level. Erection loads to be taken in design. For bolts nuts and washers reference to be made to clause 2.4 of IS-800-2007. Effective sectional area should be as per clause 7.3.2. Gusseted column bases should be as per clause 7.4.2. In the design laterally supported beams reference should be made to clause 8.3.4 Combined stresses refer clause 9.3 of IS-800-2007.

#### A.7 The Design of Crane Girder should account for the following:

01. Impact Factor 25%. Limiting deflection as per IS-800-2007.
02. Minimum thickness of web refer clause 8.6.
03. Crane Girder to be designed for Tandem operation of 1 nos of 100T EOT and 2 nos 20T in Extension New Fabrication Bay.
04. Buffer stop to be designed for Energy absorption.
05. 06. Knee braces from the crane girder to the crane run way columns are not recommended.
06. Crane runway girders are to be designed as simply supported direct interconnection that would restrain relative rotation between adjacent ends of successive girders is not recommended.
07. Crane runway girders shall be designed and detailed and fabricated to resist fatigue damage





08. Crane runway girders need not have bottom flanges stiffened by means of abracing system connected to an adjacent girders or stiffening truss.
09. Intermediate stiffeners shall be welded to the top flange with a full penetration (beveled) weld and should be stopped shot of bottom flange. The end bearingstiffness should be welded to the top and bottom flange with a full penetration (beveled) weld. Alternatively end bearing stiffness may be welded to the bottomflange to obtain full bearing.
10. All welds between stiffeners and web plates or flange plates are to becontinuous weld.
11. Brackets should not be used to support crane runway girders.
12. Web plate and Flange plate splice welds shall be 100% inspected byradiographic or ultrasonic inspection. Where flange to web welds are completepenetration welds they should be 100% inspected by ultrasonic inspection. Whereflange to web welds are fillet welds they should be 100% inspected by liquidpenetrant or magnetic particle inspection.
13. In the design of crane girder web it is to be noted that tension field designintroduced into the AISC specification in 1961 is not permitted for crane runwaygirders.

#### A.8 TEMPERATURE EFFECTS

Thermal effects to be considered for temperature variations as under-

Season	Average.	Average
	Max.	Min.
Peak summer	*46.5 °C	22.0 °C
Peak Winter	16.0 °C	*2.4 °C

\* indicates: extreme temperatures recorded.

Design value: -

Case – 1:

Member erected in summer at ambient temperature of around 40.0 °C.

Anticipated fall in temperature suffered during life of structure =

$$40 - 2.4 = 37.6 \text{ °C}$$

Case – 2:

Member erected in winter at ambient temperature of around 8.0 °C

Anticipated rise in temperature suffered during life of structure =  $8 - 46.5 = - 38.5 \text{ °C}$

Average of rise and fall in temperature =  $(+ / -) 38 \text{ °C} = \text{Design value to be adopted.}$

#### B.0 DESIGN REFERENCES

- B.1 All designs shall be done in accordance with BIS- Standards as per specification of works.
- B.2 Only in the case of design criteria not being available in Indian Standard Codes, reference can be made to other International Codes / Standards / Manuals, as applicable to Design of Steel structures of the type specified.

Use of standards other than BIS Codes shall be subject to approval of LMRC.

#### C.0 INCREASE IN PERMISSIBLE STRESSES

Increase in permissible stresses in general shall be as per Clause 3.9 of IS: 800.

Deviations from codal requirements: -



- (i) Clause 3.9.4 of IS: 800 would be applicable only for design of members subject to forces due to 'Basic Wind Load only, and not for conditions where "Local Wind Effects" are considered for design
- (ii) For members designed to withstand forces due to 'Local Wind Effects', provision as per clause 3.9.2.1 is to be followed.

**D.0 DEFLECTION LIMITS**

Deflection limits of members shall generally be as per clause 3.13 of IS: 800, but with the following proviso –

- i) Maximum deflection limit for purlins checked under various combinations of dead loads and imposed loads is to be restricted to span/250.  
For combinations of dead, imposed and wind loads, purlin deflection is to be limited to span / 200.
- ii) For columns in a single storey building, maximum horizontal deflection at the cap of columns due to worst combination of forces should not exceed the following limits: -

Load combination (Worst of)	For columns not supporting crane gantry girders	For columns supporting crane gantry girders
DL, LL, WL/EQ	l / 325	l / 425
DL, LL, WL/EQ & Temp	l / 250	l / 425

'l' is the actual length of the column.

- iii) Maximum permissible deflection at tip of cantilevers shall be limited to span / 325.

**E.0 MATERIAL SPECIFICATION**

- E.1 All structural components other than purlins and side cladding runners shall be made from Hot Rolled Sections and plates with Grade-B steel, of Designation Fe410W 'B' having a minimum tensile strength of 410 M Pa, conforming to IS: 2062. Minimum metal thickness for hot rolled steel shall be 6 mm.
- E.2 Purlins and side cladding runners only, shall be made from Cold Formed Sections out of material conforming to Grade St 34-1079 of IS: 1079.  
Minimum metal thickness for Cold Formed Sections shall be 3.15 mm, UNLESS SPECIFICALLY PERMITTED BY engineer-in-Charge / Structural Consultants. .
- E.3 Bolts and nuts shall be of property class 4.6 conforming to IS: 1367. Close tolerance, or bolts in clearance holes may be used as per requirement of design.
- E.4 Holding down bolts shall be of property class 4.6 (Grade-B) conforming to IS: 1367  
And shall be in accordance with IS: 5624.
- E.5 Cladding on roof and sides of buildings shall be done with pre-formed, Silicon modified polyester (SMP) coated galvanized steel sheets of minimum thickness 0.50 mm (TCT) of approved colour.
- E.6 Roof lighting sheets shall be out of 3 mm thick, high impact strength, U-V treated, Polycarbonate sheets of approved colour / transparency, placed at suitable locations on roofs (in place of metal cladding sheets). Area of such sheets shall be generally limited to 15% of the total roof area.
- E.7 Rainwater gutters for all buildings shall be made out of 3.15 mm thick hot dipped galvanized mild steel sheets, with provision for connecting down-take pipes of appropriate size and at designed locations. Sizes of rainwater pipes and their locations will be decided at the time of final design.

**F.0 ROOF SLOPE**





- F.1 All buildings in steel construction shall have slopes of 1-vertical to 10 –horizontal.  
Purlins shall be placed normal to the slope.
- G.0 LIMITATIONS ON DESIGN ASSUMPTIONS
- G.1 PURLINS & SIDE-CLADDING RUNNERS
- G.1.1 If purlins / runners are assumed to be continuous over supports, continuity shall have to be developed at supports through proper connections to absorb the continuity moments.
- G.1.2 In case of continuous purlins / runners, temperature effects need to be considered, and such forces need to be transferred down to the foundation through the main structure and appropriate bracing or other force transfer- systems.
- G.1.3 Sag-rods and / or sag-struts may be provided as per requirements of economic design.
- G.2 COLUMNS
- G.2.1 All portal frame shall be analyzed for both fixed base and semi fixed base (50% fixed and 50% released) conditions and the combination of load cases which gives maximum forces shall be considered for design of foundation holding down bolts, columns, main rafters and connections.
- G.2.2 All columns shall be of 'Solid web' sections. These can be of standard hot rolled sections or 'built up' sections. Profiling of the sections is permissible if so desired by the suppliers.
- G.3 ROOF RAFTERS
- G.3.1 Roof rafters shall also be solid web sections, either standard hot rolled or built-up, depending on suppliers design. Trusses and castellated sections will not be acceptable.
- G.3.2 Connections of rafters to columns shall be through rigid welded/ bolted joints only.
- G.4 OTHER ELEMENTS
- G.4.1 Eaves beams, other longitudinal beams along column lines shall also be of solid web sections. These may be connected through bolts or welds as per design requirements of supplier.
- G.4.2 Crane gantry girders shall be of solid-web sections, either compound or single built up.
- G.4.3 Foundation and other holding down bolts shall be sized as per design requirement of various components being connected.
- G.4.4 For the purpose of analysis and design of sections, starting level of columns at base shall generally be considered as 800 mm below floor level. The exact depth of fixity of columns shall be got clarified from Structural Consultants before the final analysis / design is taken up by the supplier.

